

Direct Seeding of Soybean Using a Modified Conventional Seeder

Davut Karayel
Akdeniz University
Turkey

1. Introduction

A seeder should place seed in an environment for reliable germination. The main objective of sowing is to put seeds at a desired depth and spacing within the row. Uniform seed distribution within the soil result in better germination and emergence and increase yield by minimizing competition between plants for available light, water, and nutrients. A number of factors affect seed distribution in soil. Seed metering system, seed delivery tube, furrow opener design, physical attributes of seed and soil conditions all play a part in determining seed distribution.

Conservation tillage is defined to be any tillage or sowing system which leaves at least 30% of the field covered with crop residue after sowing has been completed. In such soils, erosion is reduced by at least 50% as compared to bare, fallow soils. In the last three decades, no-till sowing practices that promote soil and water conservation have slowly become an accepted alternative to conventional tillage systems.

Improvements in the design of minimum and no-till seeders, lower cost and more effective herbicides, a better understanding of the role of tillage in crop production systems, and an increased emphasis on residue management have been key factors in the successful shift to no-till sowing (Baker et al., 2002).

The continuous development of conservation tillage technologies has led to studies on the performance of seeders. No-till sowing requires a seeder that will effectively penetrate untilled soil and place the seed at the optimum depth for rapid plant emergence.

No-till seeders and drills must be able to cut and handle residue, penetrate the soil to the proper sowing depth, and establish good seed-to-soil contact. Many different soil conditions can be present at the time of sowing. Moist soils covered with residue, which may also be wet, can dominate during late fall and early spring and occasionally in the summer. Although this provides for an ideal seed germination environment, such conditions can make it difficult to cut through residue. In contrast, hard and dry conditions may also prevail. This is especially common when no-tilling soybean into wheat stubble during the hot, dry months of June and July. Although cutting residue is easier during dry conditions, it is more difficult to penetrate the hard, dry soils. Proper timing, equipment selection and adjustments, and management can overcome these difficult issues.

Two of the keys for success with no-till equipment are proper handling of the previous crop residue and weed control. If these issues are not considered, then the ability of the seeder or drill to perform its functions is greatly limited. The residue has to be uniformly spread

behind the combine if the opening devices are going to cut through the material and plant at a uniform depth. It is very difficult for the seeder to cut the residue if the combine has left a narrow swath of thick residue and chaff (Grisso et al., 2009).

Probably the primary difference between conventional seeder systems and those designed for conservation tillage systems is weight. Since the openers and soil engaging devices must penetrate much firmer soils and cut the residue, the conservation seeder systems are built heavier and have the ability to carry much more weight than conventional systems. For adequate coulter penetration, weight may have to be added to the carrier. Some seeder use a weight transfer linkage to transfer some of the tractor weight to the coulters to ensure penetration. Because coulters are usually mounted several feet in front of the seed opening/placement device (in the case of coulters caddies even further), many use wide-fluted coulters, a pivoting hitch or a steering mechanism to keep the seed openers tracking in the coulters slots.

Wide-fluted coulters (5-8 cm wide) perform the most tillage and open a wide slot in the residue. They allow faster soil warm-up (which may be a disadvantage in some double-cropping situations) and prepare an area for good soil-to-seed contact. However, because of the close spacing, fluted coulters require more weight for penetration, disturb more soil surface, and bury more residue. In wet soil conditions, fluted coulters may loosen too much soil, which could prohibit good seed-to-soil contact. The loose, wet soil may stick to the seed openers and press wheels resulting in non-uniform depth control and clogging.

Narrow-fluted coulters or narrow bubble coulters, ripple coulters and turbo-rippled coulters do not require as much weight for penetration and do not throw as much soil out of the seed furrow as the wide-fluted coulters.

Most no-till seeder is equipped with independent sowing units that should allow at least 15 cm of vertical movement. This will allow smooth transit over non-uniform surface and adjust for root stubs and other obstacles. These units are sometimes staggered which helps with the unit function (more side-to-side space) as well as more space for the residue to flow through the system. These units should be equipped with heavy down-pressure springs and sufficient weight to ensure penetration of both the coulters and seed furrow openers into untilled soil. Usually these springs are adjustable and multiple springs can be added until sufficient pressure is achieved.

Some no-till seeders are not equipped with coulters. These seeders use the seed furrow openers to cut and place the seed. Several seeder systems have a staggered double disk seed furrow opener without a coulters. The leading disk cuts the residue and the second aids in opening the seed furrow. Some manufacturers use a single, large disk set at a slight angle. These units require less weight.

Sufficient weight must remain on the press wheels to ensure firming of the seed into the soil. Wet soil is easily compacted and care must be taken not to over pack the soil, making it difficult for seedling roots to penetrate the soil. In dry soil conditions, extra closing force may be needed. The key is to evaluate seed-to-soil contact, not the top of the seed-vee. As long as the contact is there, something as simple as a harrow that acts to close the top of the vee and pull light residue cover back over the vee may be all that is needed. This is a common practice on drills that use a narrow press wheel (Grisso et al., 2009).

Depth control of most no-till seeder systems comes in three methods:

1. front wheel in front of the seed furrow opener,
2. side gauge wheel adjacent to the seed furrow device, and
3. presswheel behind the seed furrow opener.

In all three cases, keep adequate pressure on the front, gauge or press wheel to force the openers into the soil to the proper depth. A harrow behind a seeder ensures seed coverage and redistributes residue for effective conservation measures. Regardless of the depth control, wide-flat press wheels are unacceptable for no-till since they will ride on the firm soil adjacent to the seed furrow and will not firm the seed into soil. A wide press wheel equipped with a rib that runs on the sides of the seed furrow or a rib that runs directly over the furrow to press the seed is adequate for good seed-to-soil contact. Karayel and Ozmerzi (2009) evaluated three depth-control components in two different field conditions (Fig. 1). Runner and double disc openers were used with each depth-control. The vertical and horizontal distribution of seeds in the soil and percentage of emerged seedlings were determined to evaluate performance of depth-control components. The horizontal distribution of seeds was described by using the mean, standard deviation, and coefficient of variation of seed spacings. The vertical distribution of seeds was described by using the distribution area of seeds in addition to the mean, standard deviation, and coefficient of variation of sowing depths. Mean seed spacing was not affected by depth-control component but mean sowing depth was affected. The minimum coefficient of variation of sowing depth and distribution areas of seeds were obtained with the side gauge wheel. The best choice for depth-control is side gauge wheel according to uniformity of vertical distribution of seeds and percent emergence. The poorest choice for depth-control is the rear presswheel which malfunctioned by sinking into loosened soil and produced deeper and the most variable sowing depths.

Morrison and Gerik (1985a & b) evaluated four depth-control components with grain sorghum and maize crops for no-tillage seeders. Depth-control components affected mean depth of sowing and depth variations. They also evaluated seeder depth-control on the basis of the predicted effects on simulated emergence for four crops. A linked front and rear depth-control wheel performed similar to rear and front depth-control wheels. Side gauge wheel were the least sensitive to type of crop residue, but required higher down pressure levels to minimize sowing depth variations.

Chen et al. (2004) investigated effects of presswheel, gauge wheel and fertilizer banding attachment on the selected seeder and crop performance. When presswheels or/and gauge wheel were not used, delayed emergence, reduced plant population and yield were observed in the normal and dry soil condition, while better crop emergence and comparable yield were obtained in the very wet sowing condition.

Soybeans are usually planted with either an agronomic row crop seeder or a grain drill. A grain drill is typically used for very narrow row configurations. Grain drills are less expensive per row than row-crop seeders but do not deliver the same metering uniformity. Soybean farmers have expressed a need for an alternative seeder combining the uniformity of a row-crop seeder with the lower cost of a grain drill.

Ess et al. (2004) conducted a research on conventional fluted-meter devices to evaluate them for variable rate soybean sowing. Fluted-meters have a cup on a rotating shaft and then an opening gate. The device performed very poorly for this test and showed that changing shaft speed or forward speed or gate opening greatly hindered the accuracy of population and spacing of the seed. As the seeds increased in size, the variability was even greater.

The drill meter devices were usually not considered for singulation accuracy because the small grains can usually compensate for the inconsistency. This may not be the case for soybeans. Some accuracy and spacing uniformity can be gained with very specific travel

speeds and fixed population but this degrades quickly if travel speed is not consistent. Another problem that contributed to the lack of spacing uniformity was the distance from the seed meter device to the seed furrow. The seed bounce and travel in the seed delivery tube greatly influenced the spacing uniformity.

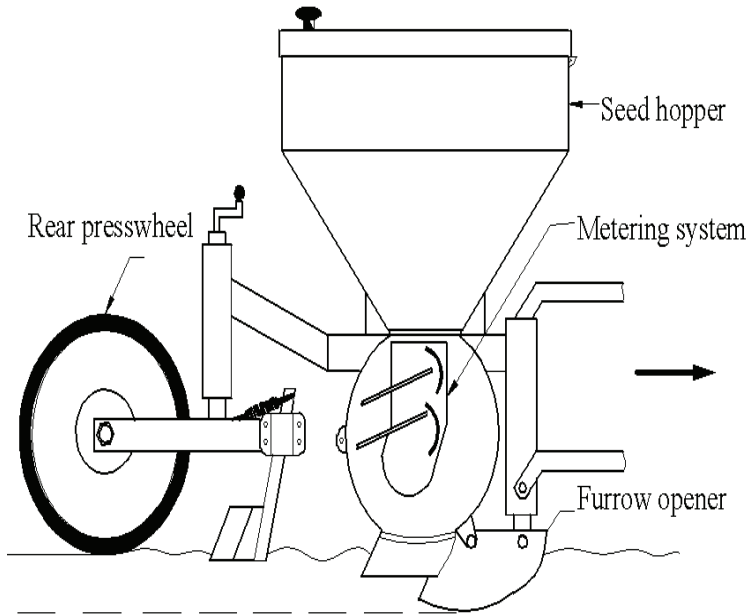

(a)

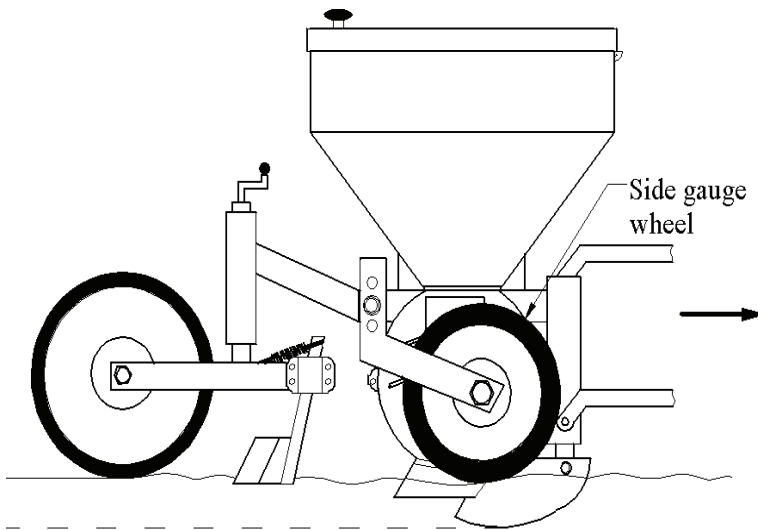

(b)

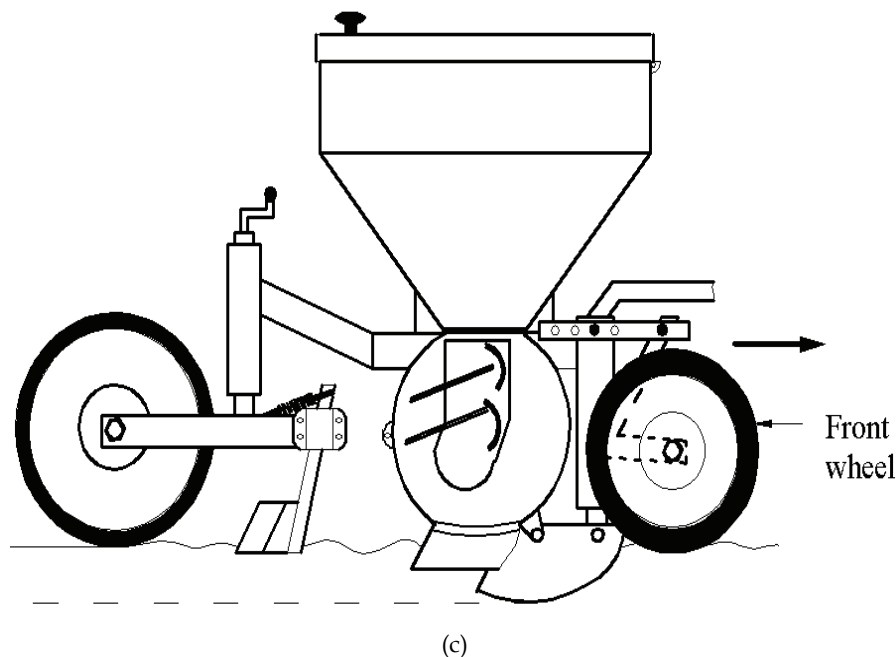

Fig. 1. Depth-control components of no-till seeders. (a) Rear presswheel, (b) Side gauge wheel, (c) Front wheel

The conventional seed meter devices for drills often result in poorly spaced stands with many gaps. To compensate for this stand variability, many operators will over-seed their stands by 10-20%. The interest in the drills with singulation devices similar to row-crop meter devices is due to the possibility to improve stands, reduce seed cost, and reduce variability seen in conventional flute-meter devices.

With these inherent problems of conventional fluted-meter devices, manufacturers have designed a spiral cup, belted meters, and meter devices that singulate out the individual seeds (potential to plant corn). Designers also moved the meter device closer to the ground to reduce the travel distance to the seed placement. Manufacturers have also adapted row-crop seeders for narrow row to give producers the seed singulation and spacing accuracy as well as a machine that could be used for both drilled and row-crops (Grisso et al., 2009).

Parish et al. (1999) designed a prototype belt-metering seeder for soybeans. The prototype was compared with commercially available seeders equipped with fluted wheel, brush, or finger metering systems. At forward speeds of 3.2 to 9 km h⁻¹, the prototype set for a nominal spacing of 24 mm was able to meter soybeans with a mean spacing of 23 to 30 mm and a quality of feed index of 38 to 46%. Sowing uniformity of the prototype was not better than the sowing uniformity of the three commercial seeders.

Some research was conducted on precision vacuum seeders to evaluate them for row crops such as maize (*Zea mays L.*) and soybean (*Glycine max L.*). Precision seeders place seeds at the required spacing and provide a better growing area per seed. There are two common types of precision seeders: belt and vacuum. Precision vacuum seeders have a metering plate with metering holes on a predetermined radius. A vacuum is applied to these metering holes by

means of a race machined in a backing plate. As the plate rotates, the vacuum applied to the metering holes enables them to pick up seeds from the seed hopper. Precision vacuum seeders provide a higher dosage preciseness with lower rate of seed damage caused by seed plate, and broader spectrum of applicability. An additional advantage of these machines is that upkeep and drift of seeds can be controlled by eyes and adjusted which also provides a more successful sowing (Soos et al., 1989).

Giannini et al. (1967) published a thorough discussion of the need for precision sowing and discussed the development of a very successful precision seeder that used vacuum principles for singulation. Compared with the standard bulk metering seeder, this vacuum seeder used 90% less seed, thus reducing thinning time and resulting in improved yields. Hudspeth and Wanjura (1970) developed a vacuum meter system for sowing cotton (*Gossypium hirsutum* L.). Field tests showed that plant spacing and emergence were better when the vacuum meter system was used compared with a conventional grain drill with a double-run meter, which consists of a cast iron disc corrugated at both sides by fine and coarse pockets to suit different sizes of seeds. Parish and Bracy (1998) hypothesised that a vacuum seeder should meter a wider range of seed size more uniformly than a belt seeder, since the holes in the seed plate must only be smaller than the smallest seeds in the lot. Karayel and Ozmerzi (2004) assessed the use of a precision vacuum seeder for hill-drop sowing of melon (*Cucumis melo*) and watermelon (*Citrullus lanatus*). They reported that the precision vacuum seeder was effective at hill-drop sowing of melon and watermelon.

Little work has been done to evaluate using possibilities of conventional seeders for minimum and no-till systems. Raoufat and Mahmoodieh (2005) evaluated field performance of a conventional row crop seeder with two types of coulters attachment (plain/notched coulters) in two tillage systems (mouldboard/ chisel ploughs) for maize cropping after a wheat harvest. Chisel ploughing followed by a coulters-seeder appears to be a good alternative to a more conventional cropping system, offering advantages for conservation farming and better plant establishment. Raoufat and Matbooei (2007) developed proper cleaning wheels for conventional precision seeders and evaluated the field performance of the new row cleaner seeder at various levels of previous wheat residue and forward speed for no-till sowing of maize. Row cleaners performed best at the forward speed of 10 km h⁻¹, retaining an average residue cover of 920 kg ha⁻¹ compared to 1350 kg ha⁻¹ for plots planted without using row cleaners.

The primary disadvantage of no-till farming is the need for specialized sowing equipment designed to plant seeds into undisturbed soil and crop residues. Because no-till is a relatively new technique, new and different equipment has to be purchased or hired. The price of the no-till seeders is the main limitation to no-till in Turkey. Modifying the conventional seeders commonly used in Turkey may be a key factor in the shift to no-till sowing. Objective of this research was to evaluate possibilities of using a conventional precision seeder equipped with hoe and double disc furrow openers for no-till sowing of soybean.

2. Materials and methods

The study was conducted in July 2006 at the Research and Application Land, Faculty of Agriculture, University of Akdeniz, Antalya, Turkey. The soil (Eutric Vertisols by FAO/UNESCO), composed of 41% sand, 26% silt, and 33% clay, was classified as clay-loam, and residue from the previous wheat crop was on the soil. The wheat was harvested by a combine harvester leaving relatively uniform stubble. The average residue mass before the

sowing operation was 2.8 t ha^{-1} . Moisture content of the soil for the top 50 mm before sowing was 22.1% dry basis. Soybean (*Glycine max L.*) seed with a mean mass per seed of 212 mg were used for all treatments. Two different types of furrow openers (hoe and double disc) and three forward speeds (1.0, 1.5 and 2.0 m s^{-1}) were used as treatments. Plot dimensions were $5 \text{ m} \times 25 \text{ m}$ and the measurements taken in each plot were: the distance between seedlings, depth of seed placement and number of seeds emerged per day.

A precision vacuum seeder was modified to allow simultaneous mounting of two different furrow opener, with one furrow opener on one row unit and the second furrow opener on another row unit, on the two-row seeder. The seeder was a general-purpose Sonmezler PMD seeder designed for row crops such as maize and soybean (Fig. 2) (Sonmezler Company, Adana, Turkey). A seed plate operated in a vertical plane and required a vacuum of 3.5– 8.0 kPa to select a seed. Air suction from the holes of the seed plate caused the seed to stick to holes 4 mm in diameter. Seed was released from the rotating plate by blocking air suction over the opener, which had no seed tube.

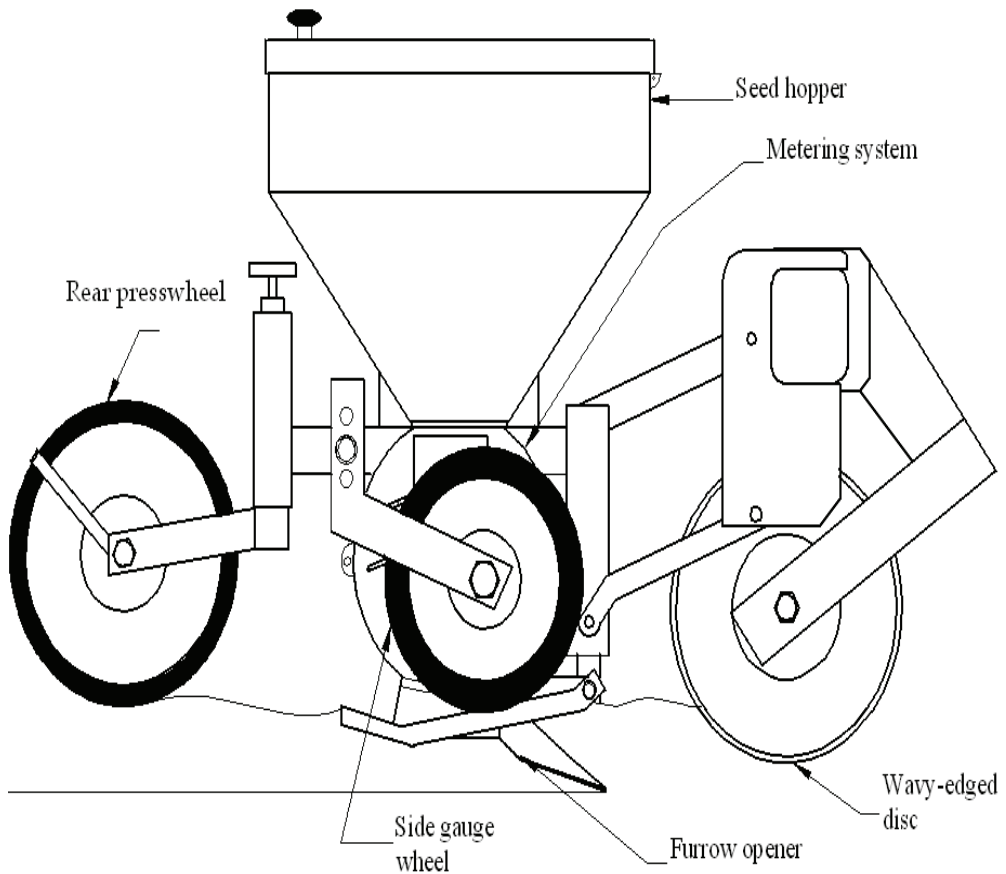

Fig. 2. The modified precision vacuum seeder for no-till sowing (Direction of travel is left to right)

Each sowing unit was independently mounted on a four-bar parallel linkage equipped with joint springs to apply downward force on the sowing unit and was composed of a furrow opener followed by a presswheel, which closed and compacted the seed furrow. The seed metering system was adjusted for a nominal seed spacing of 102 mm in the row. Furrow openers was adjusted for a nominal sowing depth of 50 mm. The seeder was calibrated in the laboratory before field operation.

The furrow opener of the precision vacuum seeder was a runner-type opener (widely used when cropping maize and soybean in ground that has been conventionally tilled) before modifying the seeder for no-till sowing. Hoe and double disc-type furrow openers were used in the study because disc and hoe openers are becoming more popular where minimum and no-till systems are used and there is a greater amount of residue left on the surface. The hoe-type furrow opener was made from grey cast iron, with its cutting edge quenched to increase hardness and wear resistance. A pair of mild steel wings were welded to either side of the opener to complete the assembly. The double disc-type furrow openers were designed and fabricated from high-carbon steel plates 3.5 mm thick (Fig. 3).

Each furrow opener assembly comprised a vertical shank and an axle to which the furrow opener was mounted via a bearing. The opener shank assembly was designed in such a way that the opener could easily float, avoid side force and follow the direction of machine travel. A 400-mm diameter wavy-edged disc was mounted in front of furrow opener. The longitudinal distance from the center of each wavy-edged disc to the leading edge of the furrow opener was set at 450 mm.

The side gauge wheels, which maintained a constant sowing depth, were 60 mm × 260 mm soft crowned gauge wheels mounted vertically, at the same longitudinal position as the center of the furrow openers and positioned so the lateral distance from the inner side of the gauge wheel was 30 mm outboard of the furrow opener. There were no side gauge wheels or wavy-edged disc on the seeder before it was modified for no-till sowing. Down force of all depth-control wheels was set at 750 N based on the soil condition in this study.

After sowing, the distribution of the seeds along the length the row, sowing depth uniformities, mean emergence times (MET), and percent emergence (PE) were compared. The distances between adjacent plants in each furrow were measured. Spacings between adjacent plants were measured in the field 17 days after sowing for about 50 soybean plants for each treatment. The depths of the seeds beneath the soil surface were measured. A mark was made on the plant at the ground level. The plant was then dug out and the entire stem length below the mark was taken as the effective sowing depth. Mean sowing depth and coefficient of variation of depth were calculated from these measurements.

The sowing uniformity of the distribution pattern along the length of the row was analyzed using the methods described in Kachman and Smith (1995). The multiple index is the percentage of plant spacings that were less than or equal to half of the nominal spacing and indicates the percentage of multiple seed drops. Miss index is the percentage of plant spacings greater than 1.5 times the nominal seed spacing and indicates the percentage of missed seed locations or skips.

Quality of feed index (QFI) is the percentage of plant spacings that were more than half but no more than 1.5 times the nominal spacing. QFI is 100% minus miss and multiple indexes and is a measure of the percentages of single seed drops. Larger values of QFI indicate better performance than smaller values. Precision (PREC) is the coefficient of variation of the

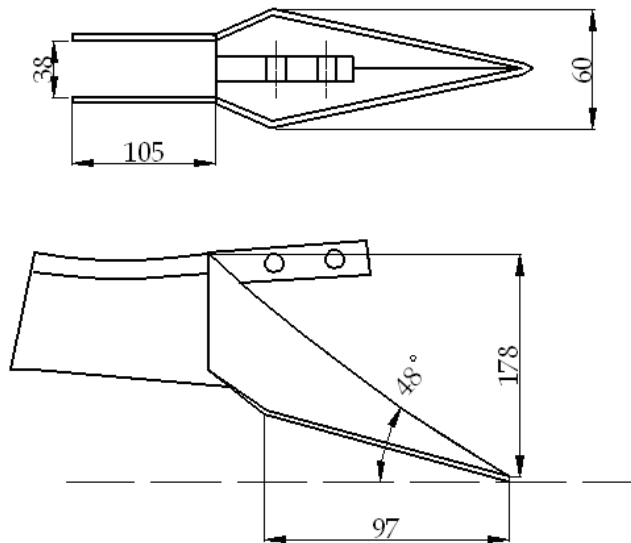

(a)

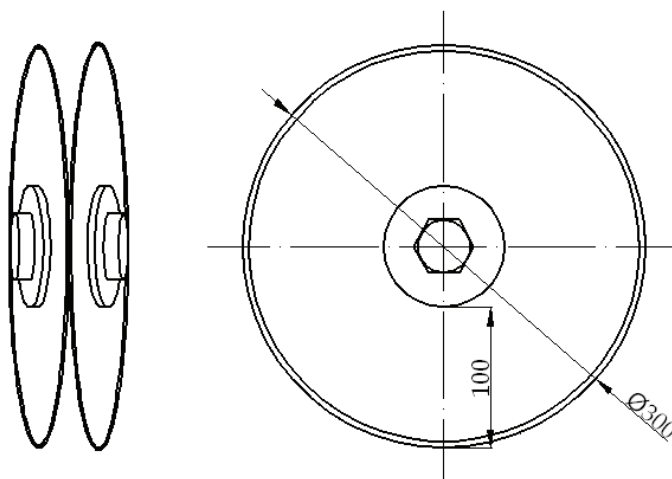

(b)

Fig. 3. Furrow openers as used in the experiment. Units of dimensions are mm. (a) Hoe-type opener (Upper view is top view and lower view is right side view), (b) Double disc-type opener (Left view is front view and right view is side view)

spacings (length) between the nearest plants in a row that are classified as singles after omitting the outliers consisting of misses and multiples. According to Kachman and Smith (1995), the theoretical upper limit for precision is 50% and this distribution of spacings would indicate that the theoretical spacing was incorrectly specified and, therefore, this level of precision is unfavourable. A practical upper limit on the value of precision is 29%. While there is a theoretical upper limit of 50% on the precision, values consistently greater than 29% should be viewed with suspicion.

Seedling counts were made in 25 m of row per treatment every day during the emergence period. From these counts, mean emergence time and percent emergence were calculated as (Bilbro & Wanjura, 1982; Karayel & Ozmerzi, 2002):

$$MET = \frac{N_1T_1 + N_2T_2 + \dots + N_nT_n}{N_1 + N_2 + \dots + N_n} \quad (1)$$

$$PE = \frac{S_{te}}{n} \quad (2)$$

where $N_{1, \dots, n}$ is the number of seedlings emerging since the time of previous count; $T_{1, \dots, n}$ is the number of days after sowing; S_{te} is the number of total emerged seedlings per meter; n is the number of seeds sown per meter; MET is the mean emergence time, in days and PE is the percent emergence.

A completely randomised design was selected for the experiment. Each treatment was replicated three times. Analysis of variance was determined using the SAS package (Cary, N.C.) to examine the effects of treatments. Duncan's multiple-range tests were used to identify significantly different means within dependent variables at $P \leq 0.05$.

3. Results and discussion

Performance of a modified precision vacuum seeder for no-till sowing of soybean was analyzed related to the sowing uniformity of the distribution pattern along the length of the row, uniformity of sowing depth, mean emergence time and percent emergence. Multiple index, miss index, quality of feed index, sowing depth, mean emergence time and percent emergence were combined for analysis of variance to determine significant differences in the variability among the parameters.

The results of the analysis show that the multiple index, miss index, and QFI of the distribution of the seeds along the length of the row were significantly influenced by the forward speed of the seeder (Fig. 4). Furrow openers did not have a significant effect on multiple index, miss index, and QFI. Increasing the forward speed of the seeder affected the performance of the furrow openers and the placement of the seeds, and caused multiple index to decreased and miss index to increase.

Larger values of quality of feed index indicate better performance than smaller values. In other words, the quality of feed index is a measure of how often the spacings are close to the nominal spacing (Kachman & Smith, 1995). Mean comparisons of the quality of feed index values, as affected by forward speed, revealed that the highest quality of feed index values were obtained at the forward speed of 1.5 m s⁻¹. The seed spacings obtained from the

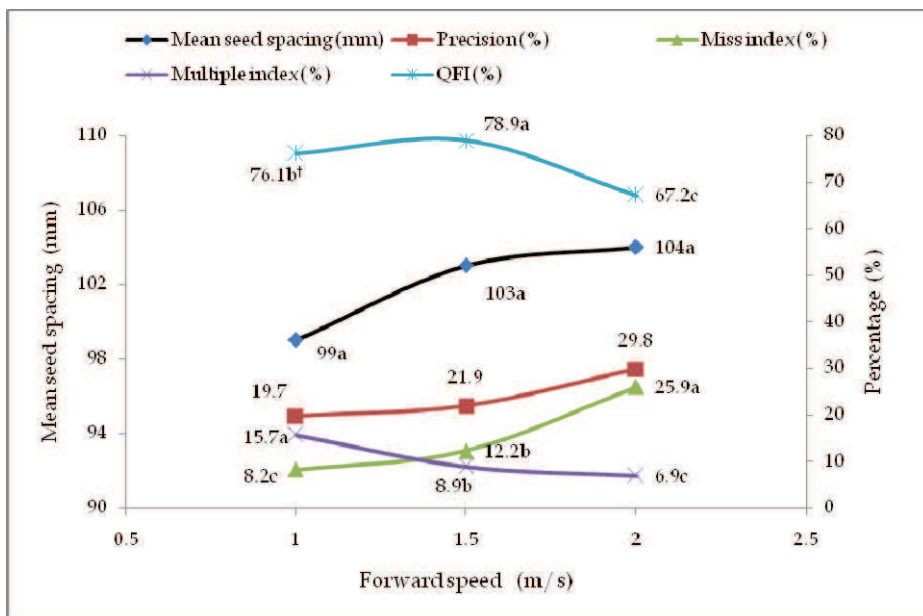

(a)

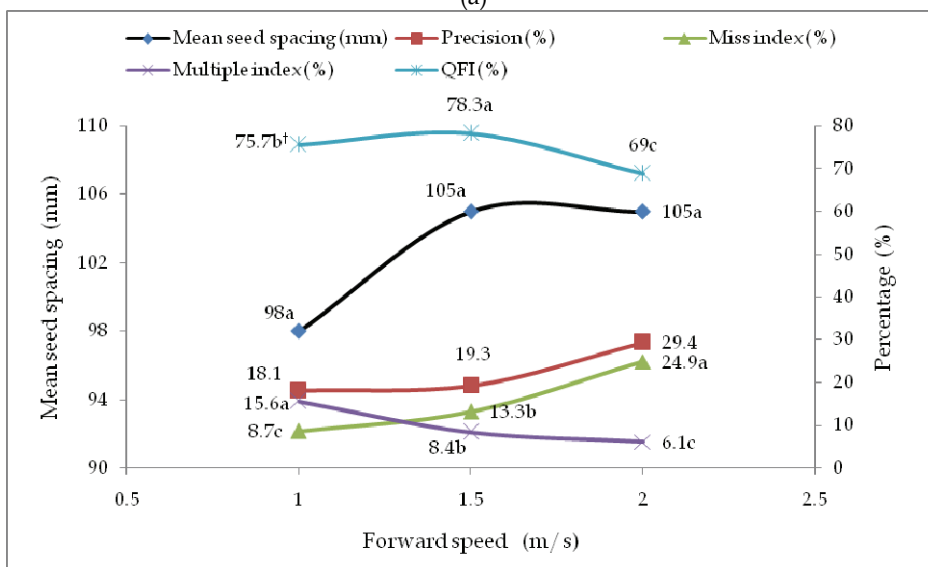

(b)

†: Means followed by same letter on a line are not significantly different at probability P=0.05, by Duncan's multiple range test.

Fig. 4. Uniformity of the sowing distribution pattern along the length of the row for soybean at different forward speeds and for different furrow openers. a) Hoe-type opener, (b) Double disc-type opener

forward speed of 1.5 m s^{-1} were closer to the theoretical spacing. Precision is a measure of the variability in spacings between plants after accounting for variability due to both multiples and skips. A practical upper limit for precision is 29%. Smaller values of precision indicate better performance than larger values (Kachman & Smith, 1995).

Comparison of data on overall average precision as affected by forward speed and furrow opener treatments shows a significantly higher precision for the forward speed of 2.0 m s^{-1} as compared to the forward speeds of 1.0 and 1.5 m s^{-1} . The negative effect of the forward speed of 2.0 m s^{-1} on the precision is evident.

In general it can be concluded that as the forward speed decreases, precision declines and seeder performance improves. The results support reports from Barut (1996), Karayel et al. (2004) and Karayel and Ozmerzi (2001) who found that the pattern efficiency of the vacuum seeder differed most at lesser or greater vacuum pressures and faster forward speeds. In this research, precisions of the seeder were poorer at greater forward speeds.

Using the double disc-type opener resulted in lower values of the precision than the hoe-type opener. The precision results for both types of seed show that the best uniform plant spacing occurred for the double disc-type furrow opener at the forward speed of 1.0 m s^{-1} and the least uniform occurred for the hoe-type furrow opener at the forward speed of 2.0 m s^{-1} . The range of precision of forward speeds of 1.0 and 1.5 m s^{-1} experienced in this study was 18.1–21.9% for soybean sowing, and these are acceptable, as they are well below 29%.

Analysis of the soybean sowing data, combined, showed significant differences in mean sowing depth occurring among forward speeds and furrow openers. Fig. 5 shows the influence of the forward speeds and furrow openers on uniformity of sowing depth. Increasing the forward speed affected the performance of the furrow openers and the placement of the seeds, and caused the mean sowing depth to decrease and the coefficient of variation of depth to increase. The actual mean sowing depths are nearly equal to nominal sowing depth for the forward speed of 1.0 m s^{-1} .

The mean sowing depth and coefficient of variation of depth for the hoe-type opener are generally greater than for the double disc-type opener for all forward speeds. While the best uniform sowing depth occurred for the double disc-type opener at the forward speed of 1.0 m s^{-1} , the worst results occurred for the hoe-type opener at the forward speed of 2.0 m s^{-1} . Fig. 6 shows that the forward speed of 2.0 m s^{-1} resulted in the least mean emergence time, and the reason might be shallower sowing depth at this relatively high forward speed. It should be noted that the results refer to mean emergence times of soybean seeds, for no-till sowing, ranging from 6.4 to 7.7 days for soybean.

Analysis of the soybean sowing data, combined, showed a significant difference in percent emergence due to forward speed and furrow opener ($P < 0.05$). Fig. 7 shows the significantly greater average percent emergence for the double disc-type opener as compared to the hoe-type opener. Increasing the forward speed affected the performance of the furrow openers and the placement of the seeds, and caused the final percent emergence to decrease.

The forward speed of 1.0 m s^{-1} had the greatest percent emergence, due to the most uniform sowing depth. Our results support reports from Heege (1993), Ozmerzi et al. (2002), Karayel (2005), Karayel and Ozmerzi (2007a & b), and Canakci et al. (2009) who found that percent emergence was negatively affected by large variability in sowing depth.

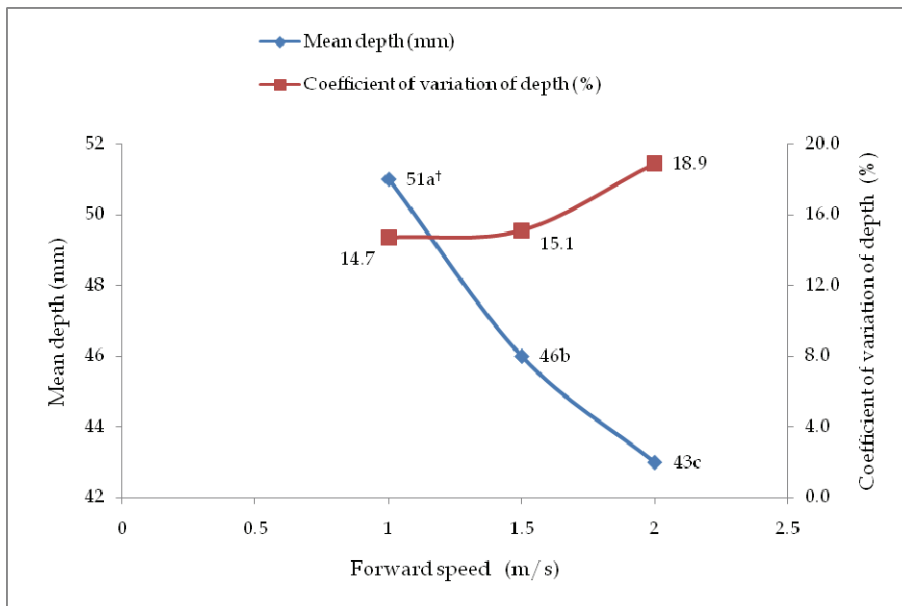

(a)

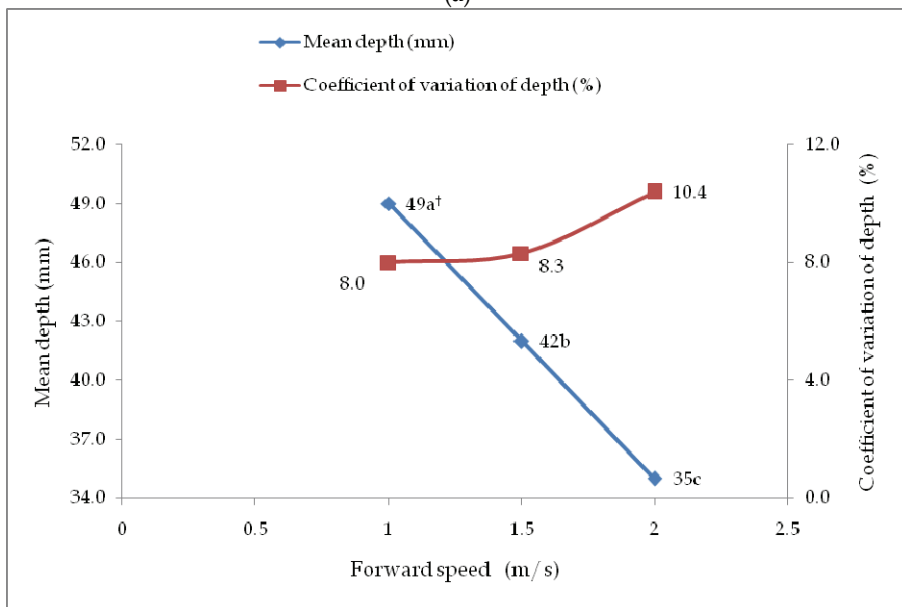

(b)

†: Means followed by same letter on a line are not significantly different at probability P=0.05, by Duncan’s multiple range test.

Fig. 5. Uniformity of sowing depth for different forward speeds and furrow openers. (a) Hoe-type opener, (b) Double disc-type opener

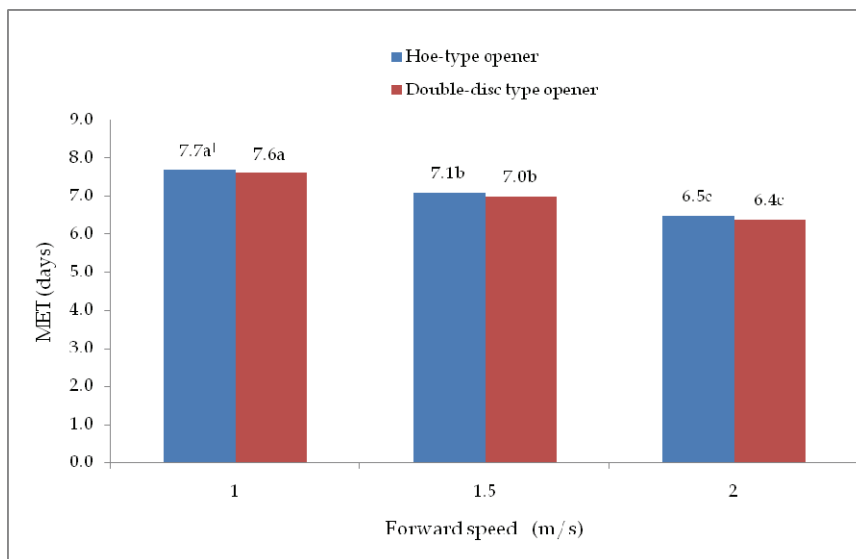

[†]: Means followed by same letter on columns are not significantly different at probability $P=0.05$, by Duncan's multiple range test.

Fig. 6. Mean emergence time (MET) of soybean seeds for different forward speeds and furrow openers

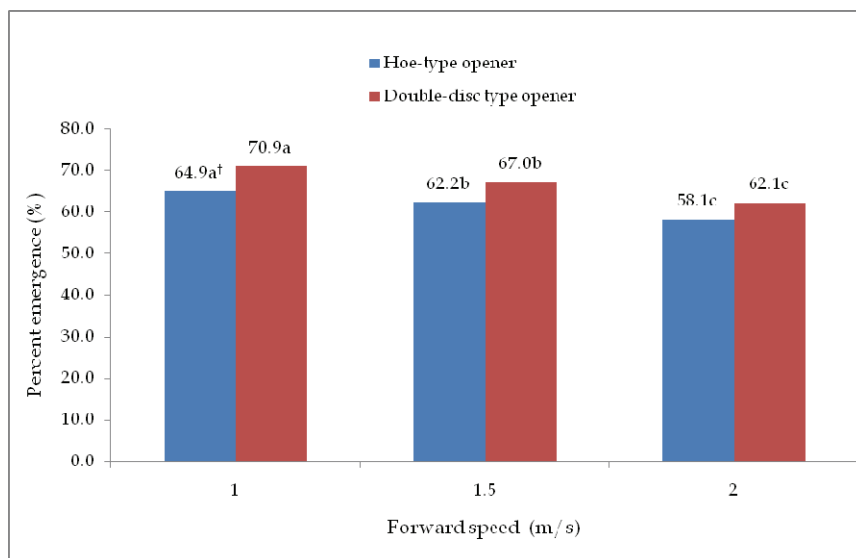

[†]: Means followed by same letter on columns are not significantly different at probability $P=0.05$, by Duncan's multiple range test.

Fig. 7. Percent emergence (PE) of soybean seeds for different forward speeds and furrow openers

4. Conclusions

The possible impact of this research is that farmers can benefit from advantages of a no-till system by modifying their existing seeders for no-till sowing of soybean. Modifying the conventional precision seeders commonly used in developing countries may be a key factor in the shift to no-till sowing.

On the basis of this research we reached the following conclusions. Increasing the forward speed of a modified precision vacuum seeder increased the precision for the distribution of seeds along the length of the row and increased the coefficient of variation of depth, due to the effect of speed on the performance of the furrow openers and placement of the seeds. The greatest emergence time and percent emergence occurred when the forward speed was 1.0 m s^{-1} .

It can be concluded that the position of the seed in the soil effects mean emergence time and percent emergence of soybean. Double disc-type openers performed better than the hoe-type opener, according to the percent emergence and the uniformity of the distribution pattern along the length of the row and sowing depth. As a result of this experiment, improved precision of no-till sowing of soybean can be attained by using a forward speed of 1.0 or 1.5 m s^{-1} with a modified precision vacuum seeder equipped with a double disc-type furrow opener.

5. Acknowledgement

The chapter was partly supported by the Scientific Research Administration Unit of Akdeniz University, Antalya, Turkey.

Some parts of this chapter was derived from an original paper published in Soil and Tillage Research [104 (2009) 121-125], entitled "Performance of a modified precision vacuum seeder for no-till sowing of maize and soybean" by D. Karayel.

6. References

- Baker, C.J.; Saxton, K.E. & Ritchie, W.R. (2002). *No-tillage Seeding: Science and Practice, 2nd edition*. CAB International, Oxford, UK.
- Barut, Z.B. (1996). *Determination of the Optimum Working Parameters of a Precision Vacuum Seeder*. PhD Thesis. Cukurova University, Institute of Natural and Applied Sciences, Adana, Turkey.
- Bilbro, J.D. & Wanjura D.F. (1982). Soil crust and cotton emergence relationship. *Transactions of the ASAE*, 25(4), 1484-1487.
- Canakci, M.; Karayel, D.; Topakci, M. & Koc, A. (2009). Performance of a no-till seeder under dry and wet soil conditions. *Applied Engineering in Agriculture*, 25(4), 459-465.
- Chen, Y.; Tessier, S. & Irvine, B. (2004). Drill and crop performances as affected by different drill configurations for no-till seeding. *Soil Tillage Research*, 77(2): 147-155
- Ess, D.R.; Hawkins, S.E; Young, J.C. & Christmas, E.P. (2004). Evaluation of the performance of a belt metering system for soybeans planted with a Grain Drill. *ASAE/CSAE Meeting Paper No: 041085*. St. Joseph, Mich.: ASABE
- Giannini, G.R.; Chancellor, W.J. & Garrett, R.E. (1967). Precision planter using vacuum for seed pickup. *Transactions of the ASAE*, 10 (2), 607-610 614.

- Grisso, R.; Holshouser D. & Pitman, R. (2009). *Equipment Considerations for No-till Soybean Seeding*. Virginia Cooperative Extension, Virginia Polytechnic Institute and State University, Virginia State, Petersburg.
- Heege, H.J. (1993). Seeding methods performance for cereals, rape and beans. *Transactions of the ASAE*, 36 (3), 653–661.
- Hudspeth, E.B. & Wanjura, D.F. (1970). A planter for precision depth and placement of cotton seed. *Transactions of the ASAE*, 13 (2), 153–155.
- Kachman, S.D. & Smith, J.A. (1995). Alternative measures of accuracy in plant spacing for planters using single seed metering. *Transactions of the ASAE*, 38 (2), 379–387.
- Karayel, D. & Ozmerzi, A. (2001). Effect of forward speed and seed spacing on seeding uniformity of a precision vacuum metering unit for melon and cucumber seeds. *Journal of Faculty of Agriculture Akdeniz University, Antalya*, 14 (2), 63–67.
- Karayel, D. & Ozmerzi, A. (2002). Effect of tillage methods on sowing uniformity of maize. *Canadian Biosystems Engineering*, 44, 23–26.
- Karayel, D.; Barut, Z.B. & Ozmerzi, A. (2004). Mathematical modelling of vacuum pressure on a precision seeder. *Biosystems Engineering*, 87 (4), 437–444.
- Karayel, D. & Ozmerzi, A. (2004). Effect of forward speed on hill dropping uniformity of a precision vacuum seeder. *Horticultural Technology*, 14 (3), 364–367.
- Karayel, D. (2005). *Effects of Coulters and Depth Control Units of a Seeder on Sowing Quality for Precision Sowing*. PhD Thesis. Akdeniz University, Institute of Natural and Applied Sciences, Antalya, Turkey.
- Karayel, D. & Ozmerzi, A. (2007a). Comparison of vertical and lateral seed distribution of furrow openers using a new criterion. *Soil and Tillage Research*, 95, 69–75.
- Karayel, D. & Ozmerzi, A. (2007b). Effect of furrow openers and depth control units of a seeder on field seedling emergence. *Journal of Faculty of Agriculture Akdeniz University, Antalya*, 20 (2), 153–161
- Karayel, D. & Ozmerzi, A. (2008). Evaluation of three depth control components on seed placement accuracy and emergence for a precision planter. *Applied Engineering in Agriculture*, 24(3), 271–276.
- Morrison, J. E. & Gerik T.J. (1985a). Planter depth control: I. Predictions and projected effects on crop emergence. *Transactions of the ASAE*, 28(5): 1415–1418.
- Morrison, J. E. & Gerik T.J. (1985b). Planter depth control: II. Empirical testing and plant responses. *Transactions of the ASAE*, 28(6): 1744–1748.
- Ozmerzi, A.; Karayel, D. & Topakci, M. (2002). Effect of sowing depth on precision seeder uniformity. *Biosystems Engineering*, 82 (2), 227–230.
- Parish, R.L. & Bracy, R.P. (1998). Metering nonuniform vegetable seed. *Horticultural Technology*, 8 (1), 69–71.
- Parish, R.L.; McCoy, J.E & Bracy, R.P. (1999). Belt-type seeder for soybeans. *Applied Engineering in Agriculture*, 15(2) 103–106.
- Raoufat, M.H. & Mahmoodieh, R.A. (2005). Stand establishment responses of maize to seedbed residue, seed drill coulters and primary tillage systems. *Biosystems Engineering*, 90 (3), 261–269.
- Raoufat, M.H. & Matbooei, A. (2007). Row cleaners enhance reduced tillage planting of corn in Iran. *Soil and Tillage Research*, 93, 152–161.
- Soos, P.; Szule, Z.S. & Fuzy, J. (1989). A Comparative Evaluation of Modern Sugar Beet Drills, *Bulletin of the University of Agricultural Science, Gödöllo, Hungary*, vol. 1, 66–170.

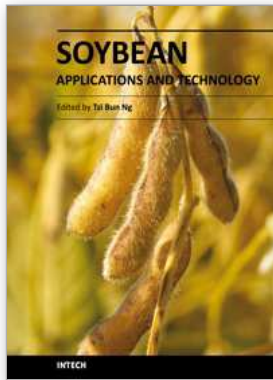

Soybean - Applications and Technology

Edited by Prof. Tzi-Bun Ng

ISBN 978-953-307-207-4

Hard cover, 402 pages

Publisher InTech

Published online 26, April, 2011

Published in print edition April, 2011

Soybean is an agricultural crop of tremendous economic importance. Soybean and food items derived from it form dietary components of numerous people, especially those living in the Orient. The health benefits of soybean have attracted the attention of nutritionists as well as common people.

How to reference

In order to correctly reference this scholarly work, feel free to copy and paste the following:

Davut Karayel (2011). Direct Seeding of Soybean Using a Modified Conventional Seeder, Soybean - Applications and Technology, Prof. Tzi-Bun Ng (Ed.), ISBN: 978-953-307-207-4, InTech, Available from: <http://www.intechopen.com/books/soybean-applications-and-technology/direct-seeding-of-soybean-using-a-modified-conventional-seeder>

INTECH

open science | open minds

InTech Europe

University Campus STeP Ri
Slavka Krautzeka 83/A
51000 Rijeka, Croatia
Phone: +385 (51) 770 447
Fax: +385 (51) 686 166
www.intechopen.com

InTech China

Unit 405, Office Block, Hotel Equatorial Shanghai
No.65, Yan An Road (West), Shanghai, 200040, China
中国上海市延安西路65号上海国际贵都大饭店办公楼405单元
Phone: +86-21-62489820
Fax: +86-21-62489821

© 2011 The Author(s). Licensee IntechOpen. This chapter is distributed under the terms of the [Creative Commons Attribution-NonCommercial-ShareAlike-3.0 License](#), which permits use, distribution and reproduction for non-commercial purposes, provided the original is properly cited and derivative works building on this content are distributed under the same license.

Soybeans Processing for Biodiesel Production

A. Bulent Koc, Mudhafer Abdullah and Mohammad Fereidouni
*University of Missouri
United States*

1. Introduction

There is a need for alternative energy sources to petroleum-based fuels due to the depletion of the world's petroleum reserves, global warming and environmental concerns. Biodiesel is a clean and renewable fuel which is considered to be the best substitution for diesel fuel (Singh & Singh, 2010). Soybean oil is one of the major feedstocks for biodiesel production. According to United States Department of Agriculture (USDA), the U.S. was the largest producer of soybean oil in the world in 2006/2007. The U.S. was followed by Argentina, China, Brazil and India in soybean oil production. The U.S. produced 34.5 % of total soybean oil in the world (United States Department of Agriculture, 2008). This amount of oil is a promising source for biodiesel production from a natural and environmentally friendly agricultural product (Patil & Deng, 2009). Although Food and Agriculture Organization of the United Nation (FAO) stated many environmental problems associated with large scale production of soybeans and maize (FAO, 2009), Life Cycle Assessment (LCA) studies indicated that cultivation of soybeans has less negative impacts on environment than some other oil seeds like sunflower and rapeseed (Sanz Requena et al., 2010).

In addition to biodiesel production, soybeans can be used to produce ethanol. Soybean hulls contain significant amount of carbohydrate for ethanol production and producers prefer to use soybean hulls for animal feeding because of its high protein content (Mielenz et al., 2009). Although, biodiesel is usually used as a blend with petro-diesel at varying ratios, it can also be used to fuel compression ignition engines alone. The results of engine emission tests showed that use of biodiesel alone produced less emissions of CO, HC, NO_x and smoke than petro-diesel (Qi et al., 2009). Conventional biodiesel production from soybeans uses separate processes for oil extraction and biodiesel conversion. Oil extraction from soybeans is accomplished by using mechanical presses, solvent extraction, supercritical fluid extraction and microwave- and ultrasound-assisted solvent extractions. The extracted oil is degummed and converted to biodiesel via transesterification. Transesterification is a chemical reaction process during which the oil is combined with alcohol, usually ethanol or methanol, in the presence of a catalyst to form fatty esters and glycerol. Reducing biodiesel production costs from \$ 3.11 per gallon to below the petro-diesel cost of \$3.0 per gallon is important to make biodiesel competitive in the diesel fuel market (Kargbo, 2010).

The objective of this chapter is to provide a literature review on oil extraction and biodiesel production from soybeans and to discuss the uses of high intensity ultrasound in processing

of soybeans for biodiesel production. Three examples of ultrasound applications in soybean processing for biodiesel production will be discussed. The first example will investigate the effects of solvent amount, oil extraction time and ultrasonication on soybean oil yield. The second example will examine the ultrasound-assisted transesterification of soybean oil for biodiesel production. The third application will investigate the feasibility of integrating soybean oil extraction and biodiesel production processes using ultrasound-assisted *in-situ* transesterification.

2. Literature review

Extracting oil from soybeans requires pretreatment of the grains. Pretreatment includes operations of cleaning and drying, dehulling and grinding (Fig. 1). Use of mechanical presses, solvent extraction, supercritical fluid extraction and microwave-and ultrasound-assisted oil extraction are the major processes practiced for oil extraction from soybeans.

Mechanical Extraction

Mechanical pressing of oil seeds is one of the most common methods of oil extraction in the world. However, single screw mechanical presses leave about 8–14% of the available oil in the oil seeds (Singh & Bargale, 2000). In mechanical extraction, effects of enzymes are neutralized by heating (Gerpen et al., 2002). An efficient way of providing heat for enzyme neutralization is using an extruder. Extruders provide enough pressure and temperature on seeds to deactivate enzymes (Gerpen et al., 2002). Jung and Mahfuz (2009) used a dry extruder with high temperature for extraction of oil and protein. They found that increased extruder pressure increased the protein solubility in soybean oil.

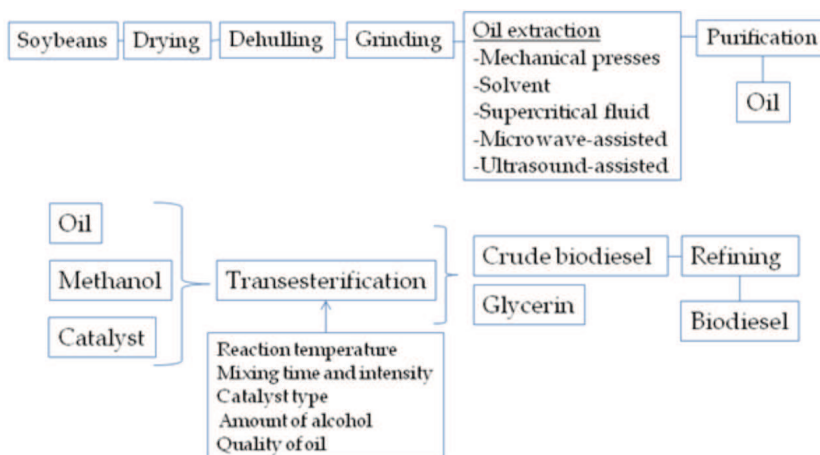

Fig. 1. Soybean processing for oil extraction and biodiesel production.

Solvent Extraction

Hexane is extensively used for oil extraction from soybeans and other oilseeds because of its low vaporization temperature, high stability, low corrosiveness and low greasy residual effects (Seth et al., 2007). Johnson and Lucas (1983) proposed to use other non-petroleum

materials instead of hexane as a solvent. They mentioned a set of problems with hexane such as the price which is dependent on fossil fuels market and its negative environmental effects (Gandhi et al., 2003). Russin et al. (2010) stated that more than 70 different solvents could be used for oil extraction from soybeans. However, the focus in many of the recent studies were mainly on using various alcohols on oil extraction (Russin et al., 2010). Seth et al. (2007) showed that the use of isopropyl alcohol caused higher extraction rates and oil recovery than hexane (Seth et al., 2007). Lou et al. (2010) compared Chilean chickpea oils extracted with hexane, isopropanol and a mixture of hexane and isopropanol in a ratio of 3:2. Mixture of hexane and isopropanol showed higher extraction rates than hexane and isopropanol alone.

Supercritical Fluid Extraction

Supercritical carbon dioxide utilized as a relatively new technique to extract oil and isoflavones from soybeans (Mendes et al., 2002). Zaidul et al. (2007) used supercritical carbon dioxide (SC-CO₂) for extraction of oil from palm kernel (Zaidul et al., 2007). Salgin (2007) used supercritical CO₂ and supercritical ethanol mixture for oil extraction from jojoba oilseeds. Their results showed an improvement on oil extraction rate. Temperature and pressure had the main effects on supercritical fluid extraction (Salgin, 2007). Kao et al. (2008) compared solvent extraction with supercritical carbon dioxide extraction and reported that supercritical carbon dioxide extraction provided higher oil yields than solvent extraction (Kao et al., 2008).

Ultrasound-assisted Extraction

Luthria et al. (2007) compared several techniques for oil extraction from soybeans. They obtained 93.3% oil yield with ultrasonication technique, which was the highest amount in comparison with other methods (Luthria et al., 2007). The ultrasound and microwave techniques used separately and in combination by Cravotto et al. (2008) for extracting oil from soybeans and micro-algae. Ultrasound/microwave extraction techniques reduced the extraction time and solvent amounts and produced higher extraction efficiency with less environmental impact than conventional (Soxhlet) extraction (Cravotto et al., 2008). Zhang et al. (2008) used both ultrasonic and conventional methods for oil extraction from flaxseed and stated that ultrasound is more efficient than the conventional method for oil extraction from flaxseed (Zhang et al., 2008). Ultrasonication method used to extract oil from Chilean chickpea by Lou et al. (2010). They indicated that use of ultrasound increased the speed of extraction and the final product quantity (Lou et al., 2010).

Microwave-assisted Extraction

Uquiche et al. (2008) investigated the oil extraction and oil quality from Chilean hazelnut. They used microwave technique in pretreatment step and followed by mechanical pressing. Their result showed that microwave application improved both the oil quality and quantity (Uquiche et al., 2008). Enzymatic hydrolysis was another method, which was proposed by Kashyap et al. (2009) to increase oil extraction from soybeans. This method was applied after pretreatment and the results showed that enzymatic hydrolysis had significant effects on oil extraction from soybean flakes (Kashyap et al., 2007). Terigar et al. (2010) compared microwaves-assisted solvent extraction with conventional solvent process on extraction of isoflavones from soybeans. They reported that oil and isoflavones yields increased by

continuous microwave system in comparison with solvent extraction method (Terigar et al., 2010).

Refining Oil

Degumming is the first step in the oil refining processes and the goal is to remove the phospholipids present in the oil by adding hydrating agents. Water and acid degumming are two main methods which were applied by the oil industries (Ribeiro et al., 2008). Pagliero et al. (2007) used membrane separation as an alternative process for oil degumming. They mentioned that membrane separation is a potential process compared to conventional degumming processes (Pagliero et al., 2007).

Biodiesel production

Transesterification method

Transesterification is a common method for biodiesel production from vegetable oils and animal fats and usually preferred instead of direct esterification (Abreu et al., 2003). In transesterification or alcoholysis, fats or oils react with alcohol in presence of a catalyst to form alkyl esters and glycerol (Meher et al., 2006). The transesterification process reduce the viscosity of oils which is higher than petro-diesel (Stavarache et al., 2005). Selecting a suitable alcohol and catalyst is important for transesterification method. Various alcohols such as methanol, butanol, ethanol, propanol and amyl alcohol can be used for transesterification. Methanol is used widely because it is relatively cheaper than other alcohols and has chemical and physical advantages over other alcohols (Ma & Hanna, 1999). In theory 3 moles of alcohols are required to neutralize 1 mole of triglyceride to produce 3 moles of fatty acid methyl ester (FAME) and 1 mole of glycerin (Leung et al., 2010). A good catalyst is also needed to obtain a reasonable rate for transesterification of triglycerides and its conversion to biodiesel (Lotero et al., 2005). Acid and alkaline catalysts can be used in the form of homogeneous or heterogeneous catalysts for transesterification process (Pereira et al., 2007). Research and industry prefer alkali catalysts, such as NaOH and KOH because alkali catalysts react faster and are less corrosive than acidic compounds (Pinto et al., 2005). High water and free fatty acid in oil reduce the effectiveness of catalysts, produce soap and require considerable amounts of catalysts. Free fatty acids (FFAs) and water in oil needs to be removed before applying base catalysis process. Marchetti et al. (2008) used acid catalyst which eliminated the above-mentioned problems. They stated that acid catalysts act better than base catalysts, because acid catalysts are able to convert higher percentage of free fatty acids (FFAs) to triglyceride. The first choice for acid catalysts is sulfuric acid which was used by several researchers (Marchetti & Errazu, 2008). In addition to the acid and base catalysts, enzyme catalysts are also considered for biodiesel production. The enzyme catalysts are gaining more interest in recent years because they don't constitute soap and their process is simple to complete. Enzymatic catalysts are currently not feasible for commercial productions since they have higher cost and need longer reaction time (Leung et al., 2010).

Ultrasound-assisted transesterification

Ultrasound technology was employed in various stages of biodiesel production. Stavarache et al. (2005) used low frequency ultrasound energy for biodiesel production and compared the results with conventional biodiesel production processes. They used three different

types of alcohols and NaOH as a catalyst. They showed that ultrasonication had a positive effect on transesterification process and reduced the process time and saved energy in the biodiesel production (Stavarache et al., 2005). Santos et al. (2009) studied the effect of ultrasonication during the process of biodiesel production from soybean oil. They used methanol and KOH as a catalyst. They showed the positive effect of ultrasound on biodiesel yield enhancement (Santos et al., 2009). Cintas et al. (2010) used high power ultrasound in a continuous system for biodiesel production from soybeans. They used ultrasound after heating the oil and premixing with a mechanical stirrer. Their results showed considerable improvement on saving time and energy (Cintas et al., 2010). Koc and McKenzie (2010) studied the effect of ultrasonication on glycerol separation during transesterification of soybean oil and optimized this process using response surfaces methodology (Koc & McKenzie, 2010). Yu et al. (2010) also mentioned that ultrasonication improved biodiesel production. They used ultrasound waves to produce biodiesel from soybean oil (Yu et al., 2010). Li et al. (2004) studied the effect of ultrasound duration on oil extraction from soybeans and compared the results with conventional extraction method. The results showed a considerable improvement on both quantity and quality of the final product. Their result showed that ultrasound was able to reduce the amount of free fatty acids (Li et al., 2004). Chand et al. (2010) compared the biodiesel production of soybean oil by mechanical stirring and ultrasonication. They showed that, required time for biodiesel production reduced by the use of ultrasonication (Chand et al., 2010).

In-situ Transesterification method

In-situ transesterification is one of the methods which have some advantages over direct transesterification. Compared to conventional transesterification, *in-situ* transesterification is faster and both oil extraction and biodiesel conversion take place in a single step. In this method, oil containing materials contact with acid or alkali alcohol directly (Fukuda et al., 2001). *In-situ* transesterification eliminates the costly hexane extraction process and reduces the long production system associated with pre-extracted oil and finally maximizes alkyl ester yield (Verziu et al., 2009). *In-situ* transesterification could be improved by increasing the alcohol volume and process temperature (Ehimen et al., 2010). Georgogianni et al. (2008) used *in-situ* transesterification with alkali catalyst and methanol and compared it to conventional transesterification. Their results indicated that the process was faster and completed in about 20 minutes (Georgogianni et al., 2008). Similar results for the same method and materials were reported by Siatis et al. (2006). Harrington and D'Arcy-Evans (1985) and Kildiran et al. (1996) tested *in-situ* transesterification with acid catalysts and methanol. Their results showed increase in total oil production. Quian et al. (2008) investigated the quality of biodiesel production from cotton seeds by *in-situ* transesterification in presence of a base catalyst. They showed that molar ratio of alcohol to cottonseed oil is important for biodiesel production (Qian et al., 2008). Similar results were reported by Santos et al. (2009). The highest biodiesel yield was accomplished when 9:1 alcohol to oil ratio was used (Santos et al., 2009). In a recent study, Shiu et al. (2010) used two-step *in-situ* transesterification with acid catalyst treatment followed by a base catalyst to produce biodiesel from rice bran. They successfully produced high amount of biodiesel in two-step *in-situ* transesterification in comparison to one step *in-situ* transesterification (Shiu et al., 2010).

3. Materials and methods

Response surfaces methodology was used to design a set of experiments to determine the effects of ultrasonication on oil extraction from soybeans. Ultrasound effect on soybean oil transesterification and in-situ transesterification were also investigated.

Materials

Soybeans (*Glycine max* L.5N416) was obtained from University of Missouri, Bradford Research and Extension Center (Columbia, MO). Analytical grade hexane was purchased from Chemstore (Columbia, MO) and used as a solvent. An electric grinder (Black and Decker®, Burr Mill CBM210, U.S.A.) was used at its fine grind setting to grind the dried soybeans. The particle size distribution of the ground seeds was determined by using a sieve analyzer (Sieve Tester SS-15, GILSON, INC, U.S.A.). An electric oven (Fisher scientific Isotemp® Model 630 F) was used to measure the moisture content. The high intensity ultrasound system used for this study was a 1000 W ultrasound processor with frequency of 20 kHz (UIP 1000, Hielscher, Germany).

Methods

Eight pounds of soybeans were soaked in warm water and dehulled manually. The dehulled soybeans were oven-dried for 24 hours and the moisture content was determined. The dried soybeans were ground and particle size distribution was determined by using a sieve analyzer. The total oil content of soybeans was determined by Soxhlet extraction. Ten grams of ground seeds placed in an extraction thimble and 150 ml hexane was refluxed using a Soxhlet extractor. The temperature of the hexane was maintained at 70 °C and the extraction continued for 10 hours. The total oil content was determined by calculating the difference between the dry weight of the ground seeds before and after Soxhlet extraction.

Design of experiments and statistical analysis

The response surfaces methodology consists of a group of empirical techniques devoted to the evaluation of relationships existing between a cluster of controlled experiment factors and measured responses according to one or more selected criteria (Fereidouni et al., 2009). ECHIP experimental design software (Wilmington, DE) was used to design the experiments and analyze the results of oil extraction stage. To design the experiments, three different factors of particle size, solvent amount and ultrasonication power were selected. The design composed of 19 experimental trials with 5 replications. Five replicate runs were performed to allow the estimation of pure error. All experiments were carried out in a random order to minimize the effect of unexplained variability in the observed responses due to irrelevant factors (Sin et al., 2006). Table 2. shows the independent variables and their levels used in the experimental design. The statistical analyses of direct biodiesel production and *in-situ* transesterification stages were carried out by measuring the standard deviation for all the results and replicating the trials twice.

| | Particle size (mm) | Ultrasound power (%) | Solvent amount (ml) |
|----|--------------------|----------------------|---------------------|
| -1 | 0.250 | 50 | 100 |
| 0 | 0.500 | 70 | 150 |
| +1 | 1.00 | 90 | 200 |

Table 1. Independent variables and their levels used in Central Composite Design (CCD).

Environmental Scanning Electron Microscope (ESEM) Images

The surface images of soybeans after grinding, before and after oil extraction with ultrasound and direct solvent extraction were captured using environmental scanning electron microscopy (ESEM, FEI Quanta 600 FE SEM, FEI Company, OR, USA).

Yield measurement

Hexane-oil mixtures were collected after ultrasonication. The samples were centrifuged at 1000 rpm for 20 min to separate the fine solid particles that may still be present in the sample. After centrifugation, 1 ml of supernatant was collected from the sample and weighed using a precision scale. Hexane was evaporated by placing the samples in an oven at 105 °C for 2 hours. The initial and final weight of the samples were measured and recorded. The oil yield (Y) was determined by using the following formula (Equation 1).

$$Y = \frac{w_e}{w_t} \times 100 \quad (1)$$

Where w_e is the weight of the extracted oil (g) and w_t is the weight of the total oil in each sample (g). The total oil content (w_t) of the soybeans was determined by using the Soxhlet extraction.

Conventional biodiesel production

Refined soybean oil was purchased from a local store. In the first step, the amount of required KOH was determined by titration. The titration amount for this study was determined to be 5.18 g KOH/liter oil. KOH (>92% purity) in the amount of 0.259 g was dissolved in 50 ml of methanol (>95% purity) and the mixture was heated to 50 °C before mixing it with the oil. The methanol-KOH solution was added to soybean oil at 50 °C with a volumetric ratio of 1:5. The mixture was blended by using ultrasound at a power level of 70% or using a mixer at 700 rpm for 5 minutes. The reaction components left to settle for 24 h at room temperature to separate glycerin from crude biodiesel. After settling, washing phase was carried out by adding 30 % (v/v) of warm water at 50 °C to the crude biodiesel and stirring for 5 min. The water-crude biodiesel mixture was left to settle for 24 h to separate soap layer from biodiesel phase. Washing process was repeated for three times to make sure that all the soap was removed from biodiesel. The washed biodiesel was then placed in an oven at 70 °C for 6 h to evaporate any water that might be present during washing.

Biodiesel production with ultrasound-assisted in-situ transesterification

The *in-situ* transesterification procedure was carried out using 30 g of dried soybeans (4.5%wb) for each trial. Fine grinding was applied to soybeans to get an average particle size of 0.25 mm. The reaction was conducted by using methanol (>95% purity) to oil molar ratio of 6:1. The amount of KOH was determined by titration and 0.03 g of solid KOH (92% purity) was dissolved in methanol. Three levels of methanol to oil volumetric ratios (15:1, 20:1 and 25:1) were used in the experimental design. The KOH-methanol mixture was added to ground soybeans and ultrasonication power was applied at two levels (70 and 90%) for 30 min. After ultrasonication, the mixture was left to settle for 2 h and the liquid phase (methanol with crude FAME) was separated and centrifuged at 1000 rpm for 10 min. The spent soybean flakes were washed by using methanol at 2:1 v/w ratio. The mixture of methanol and soybean flakes was left to settle for 2 h. The liquid phase was separated from

the solids and centrifuged at 1000 rpm for 10 min to remove the solids. Hexane was used to separate the fatty acid methyl ester from the excess methanol which was used for washing. Hexane was used at a volumetric ratio of 1:1. Water was added to the mixture at volumetric ratio of 3:1. The mixture was heated to 50 °C while stirring for 20 min. Next, the mixture was left to settle at room temperature for 24 h. The upper phase (hexane and biodiesel) was separated from methanol and washed with water at the same volumetric ratio to neutralize crude biodiesel. Sodium sulfate was used to dry water in FAME phase. Finally, hexane was evaporated at 70 °C for 6 h, and the FAME content was analyzed by GC. The spent soybean flakes were dried for 24 h at 104 °C and Soxhlet oil extraction process was used for 8 h by refluxing 120 ml of hexane through the spent soybean flakes to determine the amount of oil left in soybean flakes.

Properties of soybean oil biodiesel

The properties of biodiesel were analyzed at MFA Oil Laboratory (Columbia, Missouri). The measured properties included cloud point, flash point, sulfur content, water content, distillation, acid number, density and viscosity. A Varian 3400 equipped with Varian 8200 auto sampler and a FID detector was used to determine the fatty acid composition of the crude biodiesel. A 30 m x 0.25 mm DB-WAXeter fused silica column (Agilent Technologies) was used for the measurement. Oil samples were quantitatively weighed in a volumetric flask to prepare a solution of approximately 5-6 mg of hexane. A known aliquot containing approximately 4-5 mg of sample was pipetted to a reaction vial. One milliliter of internal standard (C17:0 methyl ester) was added to hexane and mixed well. The hexane was then evaporated to dryness using a stream of nitrogen. Two ml of BF₃/Methanol reagent (Supelco) was added, mixed and the reaction vial was capped tightly. The reaction mixture was heated to 100°C and maintained at that temperature for 30 min with occasional shaking. Then, the mixture was cooled and 1 ml of deionized water was added. The methyl esters of fatty acids were extracted with 2 ml of hexane. The extract was dried with anhydrous sodium sulfate and 3 ml of extract was injected into Gas Chromatograph. Quantitative analysis was carried out using standard fatty acid methyl esters and C17:0 (Methyl ester) as internal standard. The results of the analysis were represented in terms of the percentage of fatty acid in the oil samples. Helium, at a rate of 1 ml/min, was used as a carrier gas, the injector temperature was set at 250 °C and the column temperature was programmed to increase the temperature starting from 170°C at a rate of 1 °C/min.

4. Results and discussions

Results of ultrasound-assisted oil extraction from soybeans

The fitting of the model was investigated by analyzing the coefficients of variables and the corresponding coefficient of determination values (R^2) (Table 2). Coefficient of determination is defined as the ratio of the explained variation to the total variation and is a measure of the degree of fit (Nur 'Aliaa et al., 2010). It is also the proportion of the variability in the response variables, which is accounted by the regression analysis. When R^2 approaches unity, the empirical model fits the actual data better (Sin et al., 2006). Joglekar and May (1987) stated that R^2 should be at least 0.80 for a good fit of a model. The R^2 value for the response variable was higher than 0.80 indicating that the regression models explained the control choices which had significant effects on reaction performance. The probability (p) value of regression model was greater than 0.001 which showed no lack-of-fit.

| Term | Coefficients | SD | P |
|------------------|--------------|------------|----------|
| X_0 | 55.2109 | | |
| X_1 | 0.0182 | 0.171914 | -0.9180 |
| X_2 | 12.763 | 3.43828 | 0.0048** |
| X_3 | -0.34076 | 0.0687656 | 0.0008** |
| $X_1 X_2$ | 0.165688 | 0.192206 | -0.4110 |
| $X_1 X_3$ | -0.00390625 | 0.00384411 | -0.3361 |
| $X_2 X_3$ | -0.034825 | 0.0768823 | -0.6613 |
| X_1^2 | 0.00752604 | 0.0164441 | -0.6580 |
| X_2^2 | 5.89541 | 6.57763 | -0.3934 |
| X_3^2 | 0.000804165 | 0.00263105 | -0.7668 |
| R^2 | 0.830 | | |
| Adjusted R^2 | 0.660 | | |
| P or probability | 0.0136 | | |

Table 2. Coefficients for response of oil yield (%) depending on the control variables (X_0 : constant, X_1 : ultrasound power, X_2 : average particle size, X_3 : hexane amount).

Effect of hexane, ultrasonication and particle size on yield

ANOVA results (Table 3) shows the mean of squares, degree of freedom and *P-value* for the final response (Oil yield).

| Source | Mean squares | DF | <i>P-Value</i> |
|------------------------------------|--------------|----|----------------|
| Ultrasound power | 13.0438 | 2 | 0.8967 |
| Average particle size | 861.954 | 2 | 0.0131 |
| Hexane amount | 1456.99 | 2 | 0.0026 |
| Ultrasound power vs. Particle size | 87.8475 | 1 | 0.4110 |
| Ultrasound power vs. Hexane | 122.07 | 1 | 0.3361 |
| Particle size vs. Hexane | 24.2556 | 1 | 0.6613 |

Table 3. ANOVA for independent variables and their interactions.

According to ANOVA results, *p-value* is significant for particle size, hexane, power vs. particle size and power vs. hexane. But *p-value* is not significant for power and particle size vs. hexane. The results showed that the effect of particle size and hexane volume were highly significant on oil extraction, while ultrasound power did not show any significant effect. It was observed that the oil yield increased as the particle size was decreased. Qian et al. (2008) showed that the extraction rate of cottonseed oil increased with decreasing particle size of cottonseed flours. However, with further decrease in the particle size, the extraction of cottonseed oil was nearly constant. The optimum particle size for cottonseed was between 0.3 to 0.335 mm (Qian et al., 2008). A similar result was stated by Lim et al. (2010). They studied the effect of different particle size of *Jatropha* seeds on the oil yield. The results showed that the smaller particle size resulted more oil than larger particle size. According to Han et al. (2009), the main reason for increasing oil yield by decreasing the particle size is because of the increase in the specific surface area of oilseed interacting with the solvent.

The results showed that the hexane volume had a critical role on oil extraction although extraction by hexane was dependent on the particle size. The oil yield was increased with

decrease in hexane volume from 200 ml to 100 ml when 70% ultrasound power was used (Fig. 2). Figure 3 shows the relationship between the particle size and ultrasound power and solvent to solid ratio of 15:1.

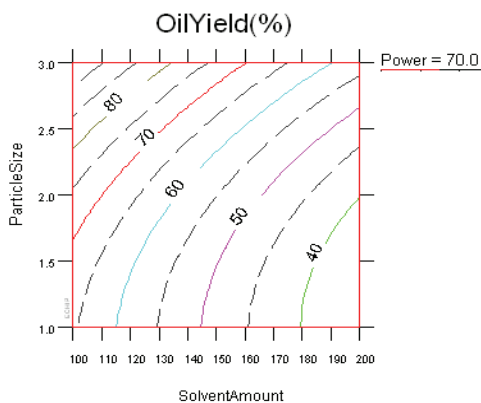

Fig. 2. Effect of particle size and solvent amount on oil yield.

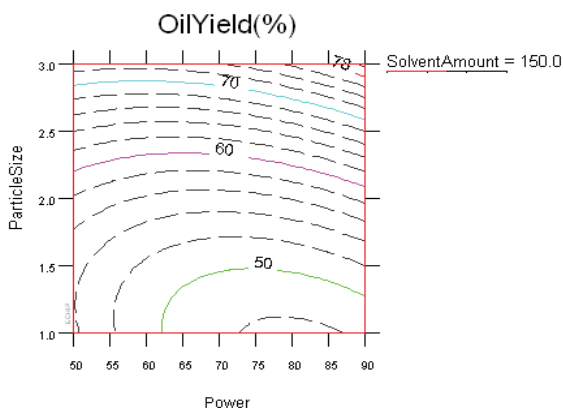

Fig. 3. Effect of particle size with ultrasound power on oil yield.

The solvent amount had significant effects on oil yield when ultrasound was applied. In the response surfaces trials, the lowest level of solvent to solid ratio was 10:1 and reducing the solvent to solid ratio increased the oil extraction rates. Additional experiments were conducted to determine the lowest solvent to solid ratio that can be used with ultrasonication. The three levels of solvent to solid ratio used in additional experiments were 4:1, 3:1 and 2:1 with ultrasonication of 30 min. Each trial was replicated twice and the measured yield values were averaged. Fig. 4. shows the oil yield change with solvent to solid ratio. Reducing the solvent to solid ratio from 4:1 to 2:1 further increased the oil yield.

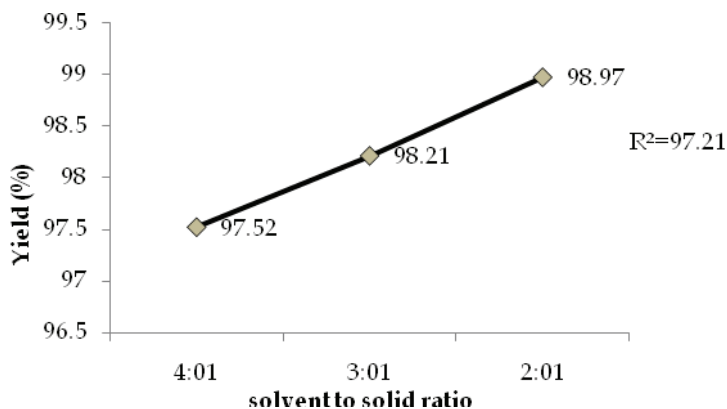

Fig. 4. Effect of solvent to solid ratio on oil extraction with ultrasonication.

Environmental Scanning Electron Microscope (ESEM) Results

Environmental Scanning Electron Microscope (ESEM) images for soybean flakes before and after extraction by Soxhlet and ultrasonication method are shown in Figures 5-7. The surface morphology of the soybeans was changed after oil extraction. Fig. 6. shows the changes on the soybean surface after 8 hr of Soxhlet extraction. Fig. 7. shows the surface of the soybean flakes after 30 min of ultrasound-assisted oil extraction. The surface of the soybean flakes after Soxhlet extraction was brighter than the samples exposed to ultrasound-assisted oil extraction. This result was compatible with Li et al. (2004) who used electron microscopy images to monitor the effect of ultrasonication time on soybean flakes during oil extraction. They showed that the extended duration of ultrasonication could improve the oil yield (Li et al., 2004). The ESEM results also verified our results on soybean oil extraction rate by

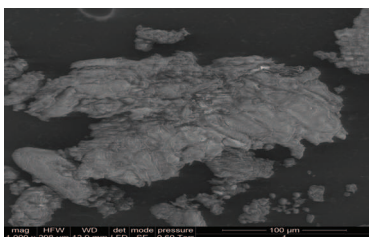

Fig. 5. Surface image of the soybean flakes before extraction.

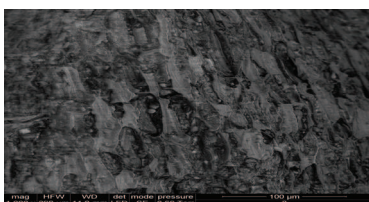

Fig. 6. Surface image of the soybean flakes after Soxhlet extraction.

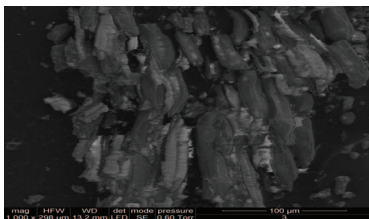

Fig. 7. Surface image of the soybean flakes after ultrasound-assisted oil extraction.

ultrasonication. As mentioned in previous section, the ultrasonication effect was not found significant on oil yield. The duration of ultrasonication might be the main reason for non-significant effect of ultrasound on the oil yield.

Results of ultrasound-assisted biodiesel production from soybean oil

Results of ultrasound-assisted transesterification process for biodiesel production from soybeans is shown in Table 4. The physical properties of biodiesel produced with ultrasound-assisted transesterification and mechanical stirring were within the ASTM standard range. High flash point of biodiesel produced by using ultrasonication (170 °C) was higher than the biodiesel produced using mechanical stirring (150 °C). Sulfur content of both soybean oil biodiesel samples was lower than the maximum standard value. Water content of both samples were higher than standard range.

Ultrasonication produced higher biodiesel yield than the mechanical stirring. The standard deviation values between the ultrasound and mechanical stirring were significantly different for biodiesel viscosity, cloud point, flash point, water content and biodiesel yield at $p > 0.05$ level.

| Properties | Mechanical | Ultrasound | ASTM | SD | Method |
|-----------------------|------------|------------|-----------|-------|-------------|
| Density (g/ml) | 0.86 | 0.88 | 0.86-0.90 | 0.01 | ASTM D 445 |
| Viscosity (°C) | 4.66 | 6.06 | 1.9-6.00 | 1.00 | ASTM D 445 |
| Cloud point (°C) | -5.56 | -1.67 | | 2.75 | ASTM D 2500 |
| Flash point (°C) | 150 | 172 | 130 | 15.55 | ASTM D 93 |
| Pour point (°C) | -5.56 | -6.67 | | 0.55 | ASTM D 5853 |
| Sulfur content (ppm) | 0.9 | 1.6 | 15 | 0.04 | ASTM D 5433 |
| Water content (ppm) | 913.4 | 1650 | 500 | 520 | ASTM D 2709 |
| Acid value (mg KOH/g) | 0.23 | 0.23 | | | |
| Biodiesel yield (%) | 94.5 | 95.5 | 0.80 | 0.57 | ASTM D 664 |

Table 4. Properties of biodiesel produced using ultrasound and mechanical mixing.

Results of ultrasound-assisted in-situ transesterification of soybean oil

The effects of ultrasound power on fatty acid methyl ester production are shown in Table 5. Increasing the ultrasound power from 70 % to 90 % with methanol to oil volumetric ratio of 25:1 increased the FAME yield from 83.9 % to 98.50 %. This value indicates that almost all of the oil available in soybeans was converted to biodiesel. Increasing the ultrasound power increased the biodiesel conversion rates. When 70 % ultrasound power was applied, the amount of linoleate acid (C18:2) in the total fatty acid composition was 49.88 %. This value increased to 56.83 % with 90 % of ultrasound power. Georgogianni et al. (2008) reported that

increasing the ultrasound power reduced the time of reaction and increased the biodiesel yield during *in-situ* transesterification of vegetable oil.

| Methyl ester | Ultrasound power (90%) | Ultrasound power (70%) | GV Vegetable oil reference |
|--------------------|------------------------|------------------------|----------------------------|
| Palmitate (C16:0) | 10.12 | 9.84 | 10.0 |
| Stearate (C18:0) | 3.36 | 2.89 | 4.68 |
| Oleate (C18:1) | 17.46 | 10.55 | 21.8 |
| Linoleate (C18:2) | 56.83 | 49.88 | 58.3 |
| Linolenate (C18:3) | 10.26 | 9.91 | 7.49 |
| Arachinate (C20:0) | 0.45 | ND | ND |
| Total | 98.50 | 83.09 | 102 |
| <i>SD</i> = 10.32 | | | |

Table 5. Fatty acid composition of biodiesel produced using ultrasound-assisted *in-situ* transesterification at methanol to oil volumetric ratio of 25:1 (ND: Not detected).

The effect of ultrasound power on FAME yield at different methanol to oil ratio are shown in Fig. 8. In general, increasing the methanol to oil volumetric ratio, increased the biodiesel yield (Haas et al., 2004). Also, increasing ultrasound power from 70 % to 90 % at different methanol levels showed significant effect on oil yield. At low ultrasound power levels, increasing the methanol to oil ratio from 15:1 to 25:1 increased the biodiesel yield from 80.96 % to 83.09 %. While at the same methanol to oil ratio, at high ultrasound power level, biodiesel yield increased from 85.92 % to 98.50 %. Catalyst concentration was kept constant for all trials. The statistical coefficient of determination showed a value of $R^2=0.96$ with high ultrasound power level, while $R^2=0.64$ with low ultrasound power level.

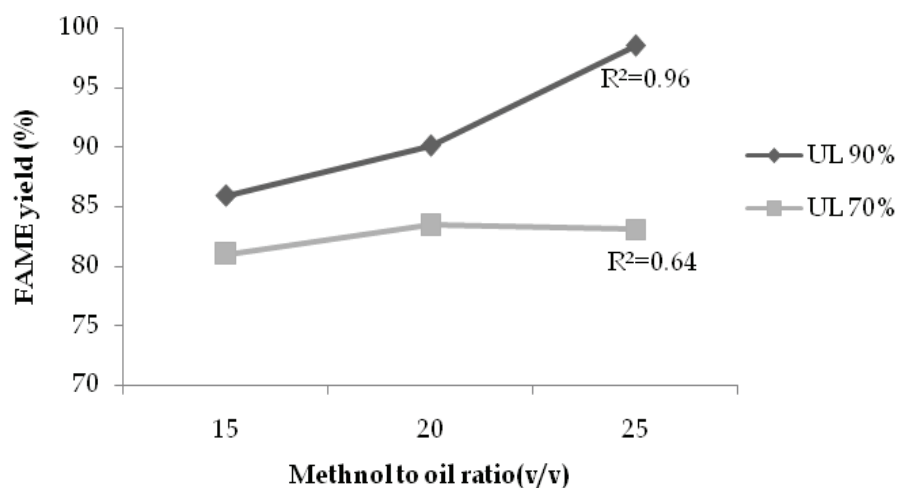

Fig. 8. Ultrasound effect on FAME yield at different methanol to oil ratio.

This value indicated that ultrasound power has high impact during *in-situ* transesterification of soybean oil with increasing methanol to oil ratio. Similar results were also reported by Qian et al. (2008). The effect of ultrasound power on various methanol to

oil ratio on oil to biodiesel conversion rate is shown in Fig. 9. The figure shows that increasing ultrasound power increased the oil yield. The coefficient of determination factor had a value of $R^2=0.89$ with high ultrasound power, whereas low power obtained $R^2=0.25$. These results confirmed the lower ability of methanol on oil extraction without ultrasonication effect in comparison with other solvents or alcoholic mixtures. Similar results were reported on methanol effect during biodiesel production by (Kim et al., 2010; Qian et al., 2008).

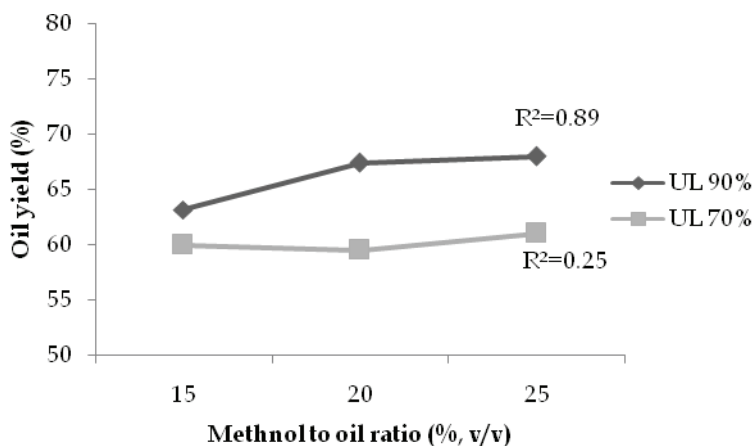

Fig. 9. Ultrasound effect on oil yield at different methanol to oil ratio.

5. Conclusions

In this study, oil extraction from soybeans and biodiesel production was performed using conventional and ultrasonication methods. The effects of ultrasonication, solvent to solid ratio and particle size on oil extraction from soybeans were investigated using response surfaces methodology. The results showed that ultrasound did not have a significant effect on oil extraction from soybean flakes, but particle size and hexane amount to solid ratio showed a significant effect on oil yield. Biodiesel production was performed by using ultrasound-assisted transesterification and *in-situ* transesterification methods. The results of *in-situ* transesterification showed that ultrasonication had a highly significant effect on biodiesel yield. The qualities of final biodiesel products were analyzed and the results showed that the physical properties of biodiesel produced with mechanical stirring and ultrasonication were within the ASTM standard ranges. Ultrasound power is an effective tool on *in-situ* transesterification during biodiesel production from soybeans. The future studies will include developing continuous *in-situ* transesterification systems that uses high intensity ultrasound for *in-situ* transesterification of soybean oil.

6. References

- Abreu, F., Lima, D., Hamú, E., Einloft, S., Rubim, J., Suarez, P. 2003. New metal catalysts for soybean oil transesterification. *Journal of the American Oil Chemists' Society*, 80(6), 601-604.

- Chand, P., Chintareddy, V.R., Verkade, J.G., Grewell, D. 2010. Enhancing Biodiesel Production from Soybean Oil Using Ultrasonics. *Energy & Fuels*, 24(3), 2010-2015.
- Cintas, P., Mantegna, S., Gaudino, E.C., Cravotto, G. 2010. A new pilot flow reactor for high-intensity ultrasound irradiation. Application to the synthesis of biodiesel. *Ultrasonics Sonochemistry*, 17(6), 985-989.
- Cravotto, G., Boffa, L., Mantegna, S., Perego, P., Avogadro, M., Cintas, P. 2008. Improved extraction of vegetable oils under high-intensity ultrasound and/or microwaves. *Ultrasonics Sonochemistry*, 15(5), 898-902.
- Ehimen, E.A., Sun, Z.F., Carrington, C.G. 2010. Variables affecting the in situ transesterification of microalgae lipids. *Fuel*, 89(3), 677-684.
- FAO. 2009. THE STATE OF FOOD AND AGRICULTURE 2009, FAO. Rome, Italy.
- Fereidouni, M., Daneshi, A., Younesi, H. 2009. Biosorption equilibria of binary Cd(II) and Ni(II) systems onto *Saccharomyces cerevisiae* and *Ralstonia eutropha* cells: Application of response surface methodology. *Journal of Hazardous Materials*, 168(2-3), 1437-1448.
- Fukuda, H., Kondo, A., Noda, H. 2001. Biodiesel fuel production by transesterification of oils. *Journal of Bioscience and Bioengineering*, 92(5), 405-416.
- Gandhi, A.P., Joshi, K.C., Jha, K., Parihar, V.S., Srivastav, D.C., Raghunadh, P., Kawalkar, J., Jain, S.K., Tripathi, R.N. 2003. Studies on alternative solvents for the extraction of oil-I soybean. *International Journal of Food Science & Technology*, 38(3), 369-375.
- Georgogianni, K.G., Kontominas, M.G., Pomonis, P.J., Avlonitis, D., Gergis, V. 2008. Conventional and in situ transesterification of sunflower seed oil for the production of biodiesel. *Fuel Processing Technology*, 89(5), 503-509.
- Gerpen, J.V., B. Shanks, R. Pruszko, D. Clements, Knothe, G. 2002. Biodiesel Production Technolgy, National Renewable Energy Laboratory.
- Haas, M., Scott, K., Marmer, W., Foglia, T. 2004. *In situ* alkaline transesterification: An effective method for the production of fatty acid esters from vegetable oils. *Journal of the American Oil Chemists' Society*, 81(1), 83-89.
- Han, X., Cheng, L., Zhang, R., Bi, J. 2009. Extraction of safflower seed oil by supercritical CO₂. *Journal of Food Engineering*, 92(4), 370-376.
- Harrington, K., D'Arcy-Evans, C. 1985. A comparison of conventional and in situ methods of transesterification of seed oil from a series of sunflower cultivars. *Journal of the American Oil Chemists' Society*, 62(6), 1009-1013.
- Jung, S., Mahfuz, A.A., 2009. Low temperature dry extrusion and high-pressure processing prior to enzyme-assisted aqueous extraction of full fat soybean flakes. *Food Chemistry* 114, 947-954.
- Kao, T.-H., Chien, J.-T., Chen, B.-H. 2008. Extraction yield of isoflavones from soybean cake as affected by solvent and supercritical carbon dioxide. *Food Chemistry*, 107(4), 1728-1736.
- Kargbo, D.M. 2010. Biodiesel Production from Municipal Sewage Sludges. *Energy Fuels*, 24 (5), 2791-2794.
- Kashyap, M.C., Agrawal, Y.C., Ghosh, P.K., Jayas, D.S., Sarkar, B.C., Singh, B.P.N. 2007. Oil extraction rates of enzymatically hydrolyzed soybeans. *Journal of Food Engineering*, 81(3), 611-617.

- Kim, M., Yan, S., Salley, S.O., Ng, K.Y.S. 2010. Competitive transesterification of soybean oil with mixed methanol/ethanol over heterogeneous catalysts. *Bioresource Technology*, 101(12), 4409-4414.
- Koc, A.B., McKenzie, E.H. 2010. Effects of ultrasonication on glycerin separation during transesterification of soybean oil. *Fuel Processing Technology*, 91(7), 743-748.
- Leung, D.Y.C., Wu, X., Leung, M.K.H. 2010. A review on biodiesel production using catalyzed transesterification. *Applied Energy*, 87(4), 1083-1095.
- Li, H., Pordesimo, L., Weiss, J. 2004. High intensity ultrasound-assisted extraction of oil from soybeans. *Food Research International*, 37(7), 731-738.
- Lim, S., Hoong, S.S., Teong, L.K., Bhatia, S. 2010. Supercritical fluid reactive extraction of *Jatropha curcas* L. seeds with methanol: A novel biodiesel production method. *Bioresource Technology*, 101(18), 7169-7172.
- Lotero, E., Liu, Y., Lopez, D.E., Suwannakarn, K., Bruce, D.A., Goodwin, J.G. 2005. Synthesis of Biodiesel via Acid Catalysis. *Industrial & Engineering Chemistry Research*, 44(14), 5353-5363.
- Lou, Z., Wang, H., Zhang, M., Wang, Z. 2010. Improved extraction of oil from chickpea under ultrasound in a dynamic system. *Journal of Food Engineering*, 98(1), 13-18.
- Luthria, D.L., Biswas, R., Natarajan, S. 2007. Comparison of extraction solvents and techniques used for the assay of isoflavones from soybean. *Food Chemistry*, 105(1), 325-333.
- Ma, F., Hanna, M.A. 1999. Biodiesel production: a review. *Bioresource Technology*, 70(1), 1-15.
- Marchetti, J.M., Errazu, A.F. 2008. Esterification of free fatty acids using sulfuric acid as catalyst in the presence of triglycerides. *Biomass and Bioenergy*, 32(9), 892-895.
- Meher, L.C., Vidya Sagar, D., Naik, S.N. 2006. Technical aspects of biodiesel production by transesterification--a review. *Renewable and Sustainable Energy Reviews*, 10(3), 248-268.
- Mendes, M.F., Pessoa, F.L.P., Uller, A.M.C. 2002. An economic evaluation based on an experimental study of the vitamin E concentration present in deodorizer distillate of soybean oil using supercritical CO₂. *The Journal of Supercritical Fluids*, 23(3), 257-265.
- Mielenz, J.R., Bardsley, J.S., Wyman, C.E. 2009. Fermentation of soybean hulls to ethanol while preserving protein value. *Bioresource Technology*, 100(14), 3532-3539.
- Nur 'Aliaa, A., Siti Mazlina, M., Taip, F., Liew Abdullah, A. 2010. RESPONSE SURFACE OPTIMIZATION FOR CLARIFICATION OF WHITE PITAYA JUICE USING A COMMERCIAL ENZYME. *Journal of Food Process Engineering*, 33(2), 333-347.
- Pagliari, C., Mattea, M., Ochoa, N., Marchese, J. 2007. Fouling of polymeric membranes during degumming of crude sunflower and soybean oil. *Journal of Food Engineering*, 78(1), 194-197.
- Patil, P.D., Deng, S. 2009. Optimization of biodiesel production from edible and non-edible vegetable oils. *Fuel*, 88(7), 1302-1306.
- Pereira, R.G., Oliveira, C.D., Oliveira, J.L., Oliveira, P.C.P., Fellows, C.E., Piamba, O.E. 2007. Exhaust emissions and electric energy generation in a stationary engine using blends of diesel and soybean biodiesel. *Renewable Energy*, 32(14), 2453-2460.
- Pinto, A.C., Guarieiro, L.L.N., Rezende, M.J.C., Ribeiro, N.M., Torres, E.A., Lopes, W.A., De Pereira, P.A.P., De Andrade, J.B. 2005. Biodiesel: An overview. *Journal of the Brazilian Chemical Society*, 16(6 B), 1313-1330.

- Qi, D.H., Geng, L.M., Chen, H., Bian, Y.Z., Liu, J., Ren, X.C. 2009. Combustion and performance evaluation of a diesel engine fueled with biodiesel produced from soybean crude oil. *Renewable Energy*, 34(12), 2706-2713.
- Qian, J., Wang, F., Liu, S., Yun, Z. 2008. In situ alkaline transesterification of cottonseed oil for production of biodiesel and nontoxic cottonseed meal. *Bioresource Technology*, 99(18), 9009-9012.
- Ribeiro, A.P.B., Bei, N., Guaraldo Gonçalves, L.A., Cunha Petrus, J.C., Viotto, L.A. 2008. The optimisation of soybean oil degumming on a pilot plant scale using a ceramic membrane. *Journal of Food Engineering*, 87(4), 514-521.
- Russin, T., Boye, J., Arcand, Y., Rajamohamed, S. 2010. Alternative Techniques for Defatting Soy: A Practical Review. *Food and Bioprocess Technology*.
- SalgIn, U. 2007. Extraction of jojoba seed oil using supercritical CO₂+ethanol mixture in green and high-tech separation process. *The Journal of Supercritical Fluids*, 39(3), 330-337.
- Santos, F.F.P., Rodrigues, S., Fernandes, F.A.N. 2009. Optimization of the production of biodiesel from soybean oil by ultrasound assisted methanolysis. *Fuel Processing Technology*, 90(2), 312-316.
- Sanz Requena, J.F., Guimaraes, A.C., Quirós Alpera, S., Relea Gangas, E., Hernandez-Navarro, S., Navas Gracia, L.M., Martin-Gil, J., Fresneda Cuesta, H. 2010. Life Cycle Assessment (LCA) of the biofuel production process from sunflower oil, rapeseed oil and soybean oil. *Fuel Processing Technology*, In Press, Corrected Proof.
- Seth, S., Agrawal, Y.C., Ghosh, P.K., Jayas, D.S., Singh, B.P.N. 2007. Oil extraction rates of soya bean using isopropyl alcohol as solvent. *Biosystems Engineering*, 97(2), 209-217.
- Shiu, P.-J., Gunawan, S., Hsieh, W.-H., Kasim, N.S., Ju, Y.-H. 2010. *Biodiesel production from rice bran by a two-step in-situ process*.
- Sin, H.N., Yusof, S., Abdul Hamid, N.S., Abd. Rahman, R. 2006. Optimization of hot water extraction for sapodilla juice using response surface methodology. *Journal of Food Engineering*, 74(3), 352-358.
- Singh, J., Bargale, P.C. 2000. Development of a small capacity double stage compression screw press for oil expression. *Journal of Food Engineering*, 43(2), 75-82.
- Singh, S.P., Singh, D. 2010. Biodiesel production through the use of different sources and characterization of oils and their esters as the substitute of diesel: A review. *Renewable and Sustainable Energy Reviews*, 14(1), 200-216.
- Stavarache, C., Vinatoru, M., Nishimura, R., Maeda, Y. 2005. Fatty acids methyl esters from vegetable oil by means of ultrasonic energy. *Ultrasonics Sonochemistry*, 12(5), 367-372.
- Terigar, B.G., Balasubramanian, S., Boldor, D., Xu, Z., Lima, M., Sabliov, C.M. 2010. Continuous microwave-assisted isoflavone extraction system: Design and performance evaluation. *Bioresource Technology*, 101(7), 2466-2471.
- United States Department of Agriculture, N.A.S.S. 2008. 2008 Agricultural Statistics Annual, United States Department of Agriculture, National Agriculture Statistic Service.
- Uquiche, E., Jeréz, M., Ortíz, J. 2008. Effect of pretreatment with microwaves on mechanical extraction yield and quality of vegetable oil from Chilean hazelnuts (*Gevuina avellana* Mol). *Innovative Food Science & Emerging Technologies*, 9(4), 495-500.
- Verziu, M., Florea, M., Simon, S., Simon, V., Filip, P., Parvulescu, V.I., Hardacre, C. 2009. Transesterification of vegetable oils on basic large mesoporous alumina supported

- alkaline fluorides--Evidences of the nature of the active site and catalytic performances. *Journal of Catalysis*, 263(1), 56-66.
- Yu, D., Tian, L., Wu, H., Wang, S., Wang, Y., Ma, D., Fang, X. 2010. Ultrasonic irradiation with vibration for biodiesel production from soybean oil by Novozym 435. *Process Biochemistry*, 45(4), 519-525.
- Zaidul, I.S.M., Nik Norulaini, N.A., Mohd Omar, A.K., Smith, J.R.L. 2007. Supercritical carbon dioxide (SC-CO₂) extraction of palm kernel oil from palm kernel. *Journal of Food Engineering*, 79(3), 1007-1014.
- Zhang, Z.-S., Wang, L.-J., Li, D., Jiao, S.-S., Chen, X.D., Mao, Z.-H. 2008. Ultrasound-assisted extraction of oil from flaxseed. *Separation and Purification Technology*, 62(1), 192-198.

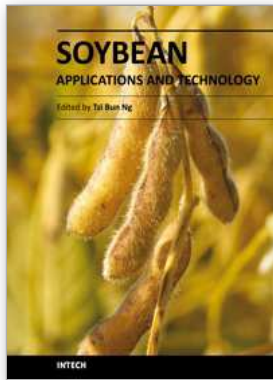

Soybean - Applications and Technology

Edited by Prof. Tzi-Bun Ng

ISBN 978-953-307-207-4

Hard cover, 402 pages

Publisher InTech

Published online 26, April, 2011

Published in print edition April, 2011

Soybean is an agricultural crop of tremendous economic importance. Soybean and food items derived from it form dietary components of numerous people, especially those living in the Orient. The health benefits of soybean have attracted the attention of nutritionists as well as common people.

How to reference

In order to correctly reference this scholarly work, feel free to copy and paste the following:

A. Bulent Koc, Mudhafer Abdullah and Mohammad Fereidouni (2011). Soybeans Processing for Biodiesel Production, Soybean - Applications and Technology, Prof. Tzi-Bun Ng (Ed.), ISBN: 978-953-307-207-4, InTech, Available from: <http://www.intechopen.com/books/soybean-applications-and-technology/soybeans-processing-for-biodiesel-production>

INTECH

open science | open minds

InTech Europe

University Campus STeP Ri
Slavka Krautzeka 83/A
51000 Rijeka, Croatia
Phone: +385 (51) 770 447
Fax: +385 (51) 686 166
www.intechopen.com

InTech China

Unit 405, Office Block, Hotel Equatorial Shanghai
No.65, Yan An Road (West), Shanghai, 200040, China
中国上海市延安西路65号上海国际贵都大饭店办公楼405单元
Phone: +86-21-62489820
Fax: +86-21-62489821

© 2011 The Author(s). Licensee IntechOpen. This chapter is distributed under the terms of the [Creative Commons Attribution-NonCommercial-ShareAlike-3.0 License](#), which permits use, distribution and reproduction for non-commercial purposes, provided the original is properly cited and derivative works building on this content are distributed under the same license.

How Growth Dynamics Affect Soybean Development across Cultural Practices

Mehmet Sincik, A. Tanju Göksoy and Z. Metin Turan
Uludag University
Turkey

1. Introduction

Determination of the most suitable planting date, plant population and cultivar for optimal yield is an important agronomic goal in soybean production. However, soybean yield is determined by interactions with environmental conditions as well as genetic yield potential. Compared to earlier planting, delayed planting reduces yields (Beatty *et al.*, 1982; Carter and Boerma, 1979; Parker *et al.*, 1981; Egli and Bruening, 2000). Yield reduction in late-planted, double-crop soybeans has been attributed to a lack of sufficient vegetative growth (Ball *et al.*, 2000 b; Herbert and Litchfield, 1984). Increasing the leaf area to maximize LI is the primary reason that increased biomass is associated with higher yields in late-planted soybean (Wells, 1991; Board *et al.*, 1992). Previous studies have indicated that optimal plant populations vary from 30,000 to 500,000 plants ha⁻¹ (Costa *et al.*, 1980; Parks *et al.*, 1982; Egli, 1988; Ennin and Clegg, 2001). In general, optimal plant population is greater under poor growing conditions than good growing conditions (Wells, 1993). Also, row spacing, which determines plant population in a unit area, is a major agronomic factor affecting soybean yield. In previous studies on planting date and row spacing, yield increases associated with narrow rows appear to be greater from late planting dates than from optimum dates (Board *et al.*, 1990; Boerma and Ashley, 1982; Boquet *et al.*, 1982). There is interest in planting soybeans in narrow rows to increase the LI for higher yields (Board and Harville, 1993). However, Purcell *et al.* (2002) stated that yield does increase at high population densities because of decreased radiation use efficiency. A previous study reported that recommended populations for optimum planting dates were insufficient for late-planted soybean because of the failure of these populations to achieve maximum LI, especially in years of low rainfall (Ball *et al.*, 2000 a). Early-maturity groups have not been used late in the season because inadequate canopy development generally occurs in the recommended populations (Kane and Grabau, 1992). Early-maturing cultivars have a shorter period of vegetative development than full-season cultivars, but the length of the seed-fill phase is about the same as for conventional cultivars (Egli *et al.*, 1978; Egli, 1993).

Growth dynamics such as LAI, LI, LIE, TDM, and CGR are major predictors of soybean yield. The relationships between seed yield and growth dynamics vary with environmental conditions and cultural practices (planting date, plant population, and cultivar, etc.). Duncan (1986) detected that greater TDM results in greater seed yield if the TDM is produced before seed initiation. In contrast, Weber *et al.* (1966) reported that both TDM and

LAI were poor predictors of seed yield. Total dry matter (TDM) is influenced by CGR, relative growth rate, relative leaf area growth rate, and net assimilation rate (Hunt, 1982). On the other hand, CGR is controlled by LAI (which influences LI) and NAR (Hunt, 1978). In addition, LI is controlled by both LAI and LIE. Greater LI in narrow rows results from either greater LAI and/or increased LI per unit leaf area (LIE) due to a more uniform arrangement (Board and Harville, 1992). Earlier authors have reported that a LAI of 4.0 was needed to reach 95% LI, and that it is essential that the canopy reach this critical LAI by flowering (Egli, 1988; Westgate, 1999). Other previous studies have demonstrated that a LAI of approximately 3.2 is required to achieve optimal CGR, 95% LI and 95% of maximum dry matter production (Shibles and Weber, 1966). It is currently accepted that a LAI of 3.5 to 4.0 is correlated with a level of 95% LI and is also a dependable measure of yield potential (Board and Harville, 1992; Westgate, 1999). Soybean cultivars and cultural practices may affect LAI, LI, LIE, CGR and TDM development. Later-maturing cultivars are more likely to meet minimum leaf area requirements than early-maturing cultivars (Holshouser and Whittaker, 2002). A suboptimal plant population reduces CGR and TDM to levels that result in yield loss (Loomis and Connor, 1992). Bullock *et al.* (1998) stated that CGR increased with decreasing rows until about R_5 , after which, rows had no significant effect on CGR. On the other hand, Egli and Bruening (2000) reported that CGRs were generally lower in the late plantings than in the early plantings, accounting for some of the reductions in seed number. Board and Harville (1992) reported that LIE was found to be important for LI increased by narrow rows early in crop growth, when LAI was low and there was little mutual shading of leaves.

In this study, we purpose to increase understanding of how certain developmental dynamics respond to planting date, plant population, and cultivar and their interactions and relations between soybean yield and developmental dynamics. Thus, the specific objectives of this research are to: (i) determinate the interactions and effects of cultural practice (planting date, plant population, and cultivar) on LAI, LI, LIE, TDM, and CGR at different development stages; and (ii) to determine the associations between seed yield and growth dynamics, such as LI, LAI, LIE, TDM, and CGR.

2. Materials and methods

2.1 Cultural practices

Field studies were conducted in 2005 and 2006 at the Research and Training Center of The Agricultural Faculty, Uludag University, Bursa, Turkey (Latitude 40° 15' 29" N, Longitude 28° 53' 39" E and altitude 72 m above sea level) on a clay soil (average 45.6% clay content). This soil had 0.11% total nitrogen content (Kjeldahl Method); 0.40 kg ha⁻¹ phosphorus (Olsen Method, P₂O₅); 5.70 kg ha⁻¹ exchangeable potassium (Ammonium Acetate Method, K₂O); 0.08% total salt; and 1.90% organic matter (Walkley-Black Method). It had a bulk density of 1.45, 1.53, and 1.50 g cm⁻³ in 0-0.30, 0.30-0.60, and 0.60-0.90 m profiles, respectively. The soil pH was 7.2. The water-holding capacity of the experimental site was 130 mm in a 0.90 m soil profile. Water-holding capacity was determined by the difference between the water content at field capacity and at permanent wilting point.

The local climate at the test site is temperate; summers are hot and dry, and winters are mild and rainy. According to long-term meteorological data (1929-2001), the annual mean rainfall, temperature, and relative humidity are 699 mm, 14.6 °C, and 69%, respectively. A sub-humid climate prevails in the region according to mean rainfall amount (from 600 to 700 mm of annual precipitation) (Jensen, 1980). Total monthly precipitation, relative humidity

and mean air temperature in 2005, 2006 and long-term at Bursa are presented in Table 1. The climate of the region is sub-humid, but rainfall amounts are extremely low in the summer period. The seasonal rainfall amount is 73 mm, which coincides with 10% of total annual rainfall, for the summer period (June, July, and August) (Table 1).

| Months | Temperature (°C) | | | Relative humidity (%) | | | Precipitation (mm) | | |
|---------------|------------------|------|------------|-----------------------|------|-----------|--------------------|-------|-----------|
| | 2005 | 2006 | Long-term* | 2005 | 2006 | Long-term | 2005 | 2006 | Long-term |
| January | 6.2 | 5.5 | 5.3 | 75.2 | 71.1 | 74.1 | 150.4 | 78.3 | 88.8 |
| February | 6.6 | 7.4 | 6.2 | 65.2 | 69.4 | 73.4 | 77.7 | 71.3 | 77.5 |
| March | 8.5 | 9.2 | 8.3 | 67.4 | 68.2 | 70.2 | 77.9 | 38.8 | 69.8 |
| April | 13.7 | 12.1 | 13.0 | 60.1 | 74.0 | 70.3 | 56.1 | 20.4 | 62.9 |
| May | 17.6 | 16.6 | 17.6 | 68.3 | 61.4 | 69.5 | 23.5 | 9.2 | 50.0 |
| June | 21.2 | 21.5 | 22.1 | 58.7 | 64.2 | 62.9 | 21.1 | 43.5 | 30.4 |
| July | 24.7 | 23.8 | 24.5 | 62.2 | 52.3 | 58.1 | 55.2 | 3.6 | 24.0 |
| August | 25.1 | 26.4 | 24.1 | 63.5 | 50.6 | 60.5 | 4.5 | 3.7 | 18.9 |
| September | 20.1 | 19.9 | 20.1 | 68.8 | 65.9 | 66.4 | 16.8 | 91.2 | 40.1 |
| October | 13.2 | 16.7 | 15.6 | 72.7 | 77.1 | 72.8 | 37.5 | 45.6 | 60.4 |
| November | 9.3 | 13.8 | 11.2 | 74.6 | 75.2 | 75.6 | 109.3 | 43.1 | 76.3 |
| December | 6.1 | 8.7 | 7.6 | 70.2 | 71.4 | 74.2 | 58.0 | 68.2 | 99.9 |
| Average/total | 14.3 | 15.1 | 14.6 | 67.2 | 66.7 | 69.0 | 688.0 | 516.9 | 699.0 |

*29-year average of evaporation values

Table 1. Mean air temperature, relative humidity, evaporation and total monthly precipitation in 2005-2006 and long-term (1929-2001) at Bursa.

The experimental design was a randomized complete block in a split-split-split plot arrangement with four replicates and two years as blocking factors. The planting dates of the main plots were mid-April and mid-May. The split plots had the following plant populations: high plant population (660.000 plants ha⁻¹), or narrow-row spacing, and low plant population (330.000 plants ha⁻¹), or wide-row spacing. The split-split plots were cultivars A-3127 (Maturity group III) and 1530 (Maturity Group IV). The split-split-split plots were the following developmental stages as defined by Fehr and Caviness (1977): V₅, R₂, R₄, and R₆. The individual plot size was 5.0 x 12.0 m = 60 m². Plantings were done by hand at a 4-cm depth on 15 April and 18 May in 2005 and on 19 April and 20 May in 2006. Fertilizer was applied before planting at a rate of 30-60-0 kg ha⁻¹ (N-P-K) according to soil test recommendations. Weed control was maintained by the pre-emergence application of metolachlor [2-chloro-N-(2-ethyl-6-methyphenyl)-N-(2-methoxy-1-methylethyl) acetamide] and imazaquin [2-(4.5-dihydro-4-methyl-4-(1-methylethyl)-5-oxo-1-H-imidazol-2-yl)-3-quinolincarboxylic acid]. The previous crop was sunflower (*Helianthus annuus* L.) in the 2005 and 2006 experiment years. Water was applied when soil moisture reached 65% of the soil field capacity in each experimental year. Irrigation was applied four times (at V₅, R₁, R₂, and R₄ stages) with a sprinkler irrigation system in both experimental years.

2.2 Data collected

Ten plants from each plot were systematically selected to measure LAI at V₅, R₂, R₄, and R₆, respectively. In addition, the average CGR (g m⁻²d⁻¹) during the V₅ to R₂, R₂ to R₄, and R₄ to

R₆ periods was determined for each plot. The crop growth rate (CGR) (e.g., during V₅ to R₂) was calculated by the following equation (Board, 2000):

$$CGR = \frac{TDM_{R_2} - TDM_{V_5}}{T_{R_2} - T_{V_5}}$$

where TDM_{V₅} and TDM_{R₂} are the total dry matter at the V₅ and R₂ developmental stages, respectively, and T is the number of days of the V₅ to R₂ period. The leaf area index (LAI) was determined by placing the leaf blades through a LI-COR 3000A portable leaf area meter. Light interception was measured between 11.00 and 14.00 h on the same day as the TDM sampling at the V₅, R₂, R₄, and R₆ developmental stages. A line quantum sensor (LI-COR LI-191 SA, Lincoln, NE) was connected to a LI-1400 data logger (1 m in length). This instrument, used to measure photosynthetically active radiation (PAR, $\mu\text{molm}^{-2} \text{s}^{-1}$), was first held above the canopy, and two measurements were then made from each plot at the soil surface (Board et al., 1992). Photosynthetically active radiation (PAR) measurements were recorded as an average of three readings made at different places of the row in each plot. Light interception (LI %) was calculated as follows (Ball et al., 2000a):

$$LI = [1 - (\text{average PAR beneath canopy} / \text{PAR above})] \times 100$$

Light interception efficiency (LIE) was determined as LI / LAI (Board and Harville, 1992). Plant samples used to determine LAI were dried in a forced air dryer at 60 °C to a constant weight. Dried plant samples were weighed to determine total dry matter.

Analysis of variance of LAI, LI, LIE, TDM, and CGR was made by using main plot, split plot, split-split plot, and split-split-split plot. Data were analyzed by year in accordance with a general linear model (SAS Inst., 1989) with mean separation according to LSD ($p = 0.05$ and 0.01). Seed yield, LI, LIE, LAI, TDM, and CGR were correlated by using year x plant population x cultivar x replication; year x planting date x cultivar x replication; and year x planting date x plant population x replication data points; within planting date x developmental stage; plant population x developmental stage; and cultivar x developmental stage treatment combinations, respectively.

3. Results

3.1 Planting date, plant population, cultivar, and developmental stage effects on LAI, LI, and LIE

Analysis of variance for LAI, LI and LIE revealed that planting date, plant population, cultivar, growth stage, and plant population x growth stage, except the planting date for LI, had highly significant effects ($P \leq 0.01$). In addition, year x plant population, year x growth stage and planting date x growth stage interactions for both LAI and LI were significant, but non-significant for LIE. Planting in mid-April resulted in significantly higher LAI and LIE than mid-May, whereas LI was not affected by planting dates. Leaf area index (LAI) and LI increases were significantly greater in the narrow rows (high plant populations) compared with the wide rows (low plant populations). In contrast, LIE was significantly higher in wide rows or low plant populations than narrow rows or high plant populations. LIE was significantly reduced in narrow rows (high plant populations), where LAI was high, probably due to the mutual shading of leaves. On average, the mid-April planting date and narrow rows (high plant populations) had near-optimum LAI for maximum LI whereas LAI

was suboptimum in the mid-May planting date and wide rows (low plant populations) (Table 2). Greater LIE levels in the mid-April planting date and narrow rows (high plant populations), compared with the mid-May planting date and wide rows (low plant populations), and failed to compensate for the near-optimum or lower than optimum LAI levels. Nevertheless, LI showed a low level in the mid-April planting date and wide rows (low plant populations).

| Treatment | LAI | LI (%) | LIE (%) |
|----------------------------|-------|--------|---------|
| <i>Planting date</i> | | | |
| Mid-April | 3.16 | 74.8 | 27.4 |
| Mid-May | 3.09 | 74.5 | 26.8 |
| LSD (0.05) | 0.003 | ns | 0.257 |
| <i>Plant population</i> | | | |
| High | 3.63 | 78.8 | 24.0 |
| Low | 2.63 | 70.4 | 30.2 |
| LSD (0.05) | 0.253 | 0.085 | 0.253 |
| <i>Cultivar</i> | | | |
| A-3127 (Early) | 3.04 | 73.9 | 27.5 |
| 1530 (Late) | 3.22 | 75.3 | 26.7 |
| LSD (0.05) | 0.014 | 0.590 | 0.200 |
| <i>Developmental stage</i> | | | |
| V ₅ | 1.24 | 46.7 | 38.2 |
| R ₂ | 2.99 | 84.8 | 29.8 |
| R ₄ | 4.44 | 85.8 | 19.4 |
| R ₆ | 3.85 | 81.4 | 21.1 |
| LSD (0.05) | 0.024 | 0.540 | 0.280 |

ns: not significant

Table 2. Means for leaf area index (LAI), light interception (LI) and light interception efficiency (LIE) for planting dates (mid-April and mid-May), plant populations (high and low), cultivars (A-3127 and 1530), and developmental stages (V₅, R₂, R₄, and R₆), over data combined of two years (2005 and 2006).

Late-maturity cultivar 1530 had higher LAI and LI but lower LIE than early-maturity cultivar A-3127 (Table 2). LAI was always suboptimum in both cultivars. LAI significantly increased from the V₅ to the R₄ stage and decreased at the R₆ stage. Light interception (LI) increased greatly from the V₅ to the R₄ stage but decreased at the R₆ stage. In contrast, LIE significantly decreased from the vegetative development stage to reproductive development stage. LAI had suboptimum levels at the vegetative and early reproductive development stages, but reached optimum levels at the reproductive development stages (Table 2).

The planting date × plant population interaction for LAI was statistically significant, but this interaction was not clear, as shown in Figure 1. However, a significant cultivar × developmental stage interaction effect on both LAI and LIE did occur ($P \leq 0.01$). These interactions indicate that late-maturity cultivar 1530 had higher LAI, but lower LIE, compared with early-maturity cultivar A-3127 at the R₂ and R₄ stages, whereas at the V₅ and R₆ developmental stages, LAI and LIE values were similar across cultivars (Figure 2).

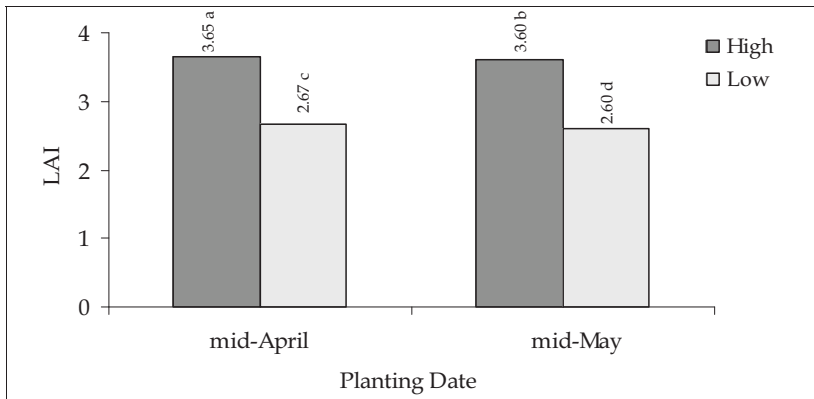

Fig. 1. Leaf area index (LAI) for soybean planted at high and low plant populations in mid-April and mid-May planting dates (2005-2006 combined data).

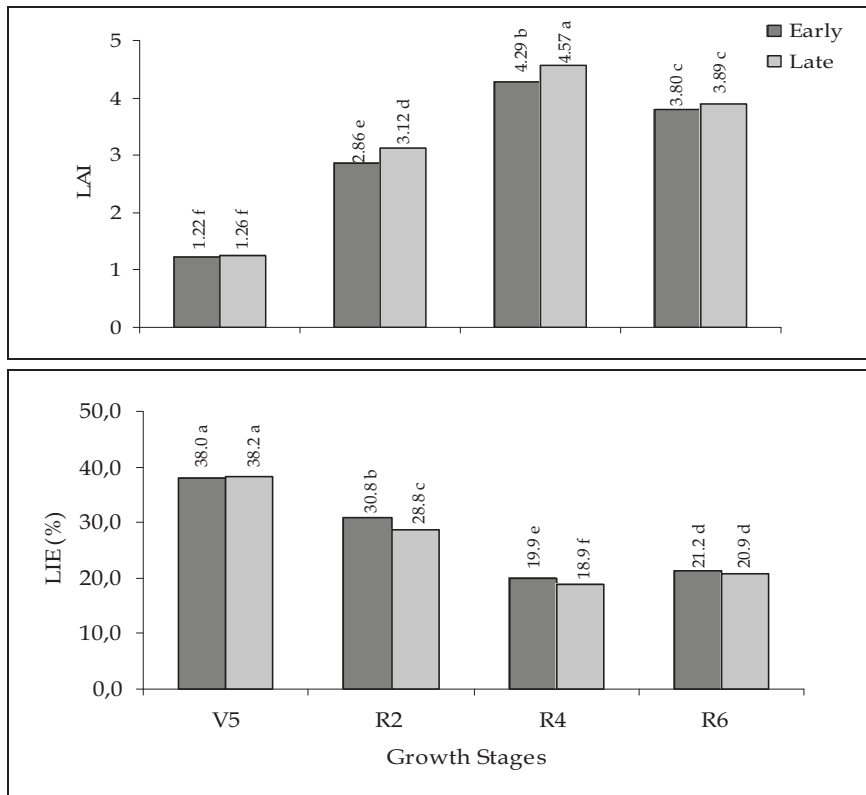

Fig. 2. Leaf area index (LAI) and light interception efficiency (LIE) during developmental stages for early and late maturity soybean cultivars (2005-2006 combined data).

Analysis of variance for LI and LIE revealed a statistically significant planting date \times plant population \times developmental stage interaction ($P \leq 0.01$), as shown Table 3. Light interception was significantly higher at the reproductive developmental stages than the vegetative developmental stage for each planting date and plant population combination. However, light interception at R_6 decreased in both plant populations at the mid-May planting compared with the mid-April planting. At the same time, high plant populations in both planting dates only had greater LIE at the vegetative stage, not the reproductive stages, while the highest LIE values were obtained from the V_5 and R_2 stages for low plant populations in both planting dates (Table 3).

| Planting date | Plant population | Developmental stage | LAI | LI (%) | LIE (%) |
|-------------------|------------------|---------------------|-----------|--------|---------|
| Mid-April | High | V_5 | 1.33 | 48.9 | 36.4 |
| | | R_2 | 3.56 | 87.6 | 24.5 |
| | | R_4 | 5.08 | 90.4 | 17.7 |
| | | R_6 | 4.62 | 89.1 | 18.9 |
| | Low | V_5 | 0.81 | 33.9 | 41.5 |
| | | R_2 | 2.16 | 77.9 | 36.1 |
| | | R_4 | 4.01 | 84.4 | 21.1 |
| | | R_6 | 3.69 | 86.2 | 23.3 |
| Mid-May | High | V_5 | 1.74 | 61.7 | 35.3 |
| | | R_2 | 3.88 | 89.8 | 23.0 |
| | | R_4 | 4.84 | 87.4 | 17.8 |
| | | R_6 | 3.94 | 75.8 | 18.7 |
| | Low | V_5 | 1.07 | 42.2 | 39.4 |
| | | R_2 | 2.35 | 83.8 | 35.5 |
| | | R_4 | 3.82 | 80.7 | 21.1 |
| | | R_6 | 3.15 | 74.4 | 23.6 |
| <i>LSD (0.05)</i> | | | <i>ns</i> | 12.9 | 6.8 |

ns: not significant

Table 3. Means for leaf area index (LAI), light interception (LI), and light interception efficiency (LIE) at different developmental stages of soybean planted at high and low plant populations in mid-April and mid-May planting dates over, data combined of two years (2005 and 2006).

The plant population \times cultivar \times developmental stage interaction was statistically significant for LI and LIE (Table 4). Light interception was much greater at the reproductive developmental stages than the vegetative stage (V_5) for each plant population \times cultivar combination. LI increases at the reproductive developmental stages were greater for the low plant populations than the high plant populations. Light interception efficiency was statistically higher at the vegetative stage (V_5) than at the reproductive developmental stages for both cultivars in the high plant population, whereas the V_5 and R_2 stages had higher LIE than the other developmental stages for each cultivar in the low plant populations (Table 4).

| Plant population | Cultivar | Developmental stage | LAI | LI (%) | LIE (%) |
|-------------------|----------|---------------------|-----------|--------|---------|
| High | A-3127 | V ₅ | 1.51 | 54.7 | 35.9 |
| | | R ₂ | 3.56 | 87.8 | 24.5 |
| | | R ₄ | 4.85 | 88.6 | 18.1 |
| | | R ₆ | 4.23 | 81.9 | 18.8 |
| | 1530 | V ₅ | 1.56 | 55.9 | 35.8 |
| | | R ₂ | 3.89 | 89.6 | 23.0 |
| | | R ₄ | 5.06 | 89.3 | 17.4 |
| | | R ₆ | 4.33 | 83.0 | 18.9 |
| Low | A-3127 | V ₅ | 0.93 | 37.1 | 40.2 |
| | | R ₂ | 2.15 | 80.0 | 37.1 |
| | | R ₄ | 3.73 | 81.3 | 21.7 |
| | | R ₆ | 3.38 | 80.3 | 23.8 |
| | 1530 | V ₅ | 0.96 | 38.9 | 40.8 |
| | | R ₂ | 2.35 | 81.7 | 34.5 |
| | | R ₄ | 4.09 | 83.9 | 20.4 |
| | | R ₆ | 3.47 | 80.3 | 23.1 |
| <i>LSD (0.05)</i> | | | <i>ns</i> | 12.9 | 6.8 |

ns: not significant

Table 4. Means for leaf area index (LAI), light interception (LI), and light interception efficiency (LIE) at different developmental stages of A-3127 and 1530 soybean cultivars planted at high and low plant populations, over data combined of two years (2005 and 2006).

3.2 Planting date, plant population, cultivar, and developmental stage effects on TDM and CGR

Analysis of variance indicated that planting date, plant population and cultivar significantly affected seed yield, total dry matter (TDM), and crop growth rate (CGR) ($P \leq 0.01$). The mid-April planting had a significantly higher seed yield and TDM, but lower CGR, than the mid-

| Treatment | Seed yield (kg ha ⁻¹) | TDM (g m ⁻²) | CGR (g m ⁻² d ⁻¹) |
|-------------------------|-----------------------------------|--------------------------|--|
| <i>Planting date</i> | | | |
| Mid-April | 3082.4 | 647.8 | 6.26 |
| Mid-May | 2752.0 | 600.6 | 7.35 |
| <i>LSD (0.05)</i> | 30.7 | 1.4 | 0.07 |
| <i>Plant population</i> | | | |
| High | 3154.6 | 648.5 | 6.69 |
| Low | 2679.8 | 599.9 | 6.91 |
| <i>LSD (0.05)</i> | 31.3 | 2.4 | 0.03 |
| <i>Cultivar</i> | | | |
| A-3127 (early) | 2793.8 | 603.1 | 7.10 |
| 1530 (late) | 3040.7 | 645.3 | 6.50 |
| <i>LSD (0.05)</i> | 28.9 | 7.9 | 0.28 |

Table 5. Means for seed yield, total dry matter (TDM) and crop growth rate (CGR) for A-3127 and 1530 soybean cultivars planted at high and low plant populations in mid-April and mid-May planting dates, over data combined of two years (2005 and 2006).

May planting (Table 5). The high plant populations gave a higher seed yield and TDM than the low plant populations. In contrast, CGR was significantly lower in the high plant populations than the low plant populations. In our study, late-maturity cultivar 1530 had a significantly higher seed yield and TDM than early-maturity cultivar A-3127, whereas cv. 1530 produced a lower CGR than cv. A-3127 (Table 5).

A year \times developmental stage interaction was observed for TDM and CGR. In both years, TDM was significantly increased during the V₅ to R₆ period, and a higher TDM was obtained in 2005 compared with the 2006 experimental year for each developmental stage. However, differences among the years in TDM were greater at the R₄ stages than the V₅ and R₂ developmental stages (Figure 3). The crop growth rate decreased significantly from 9.7-11.7 g m⁻² d⁻¹ at the V₅-R₂ period to 1.7-2.0 g m⁻² d⁻¹ at the R₄-R₆ period in both years. CGR was higher at the V₅-R₂ and R₂-R₄ periods in 2005 than the 2006 experimental year, whereas no differences were observed between 2005 and 2006 in the R₄-R₆ period (Figure 3).

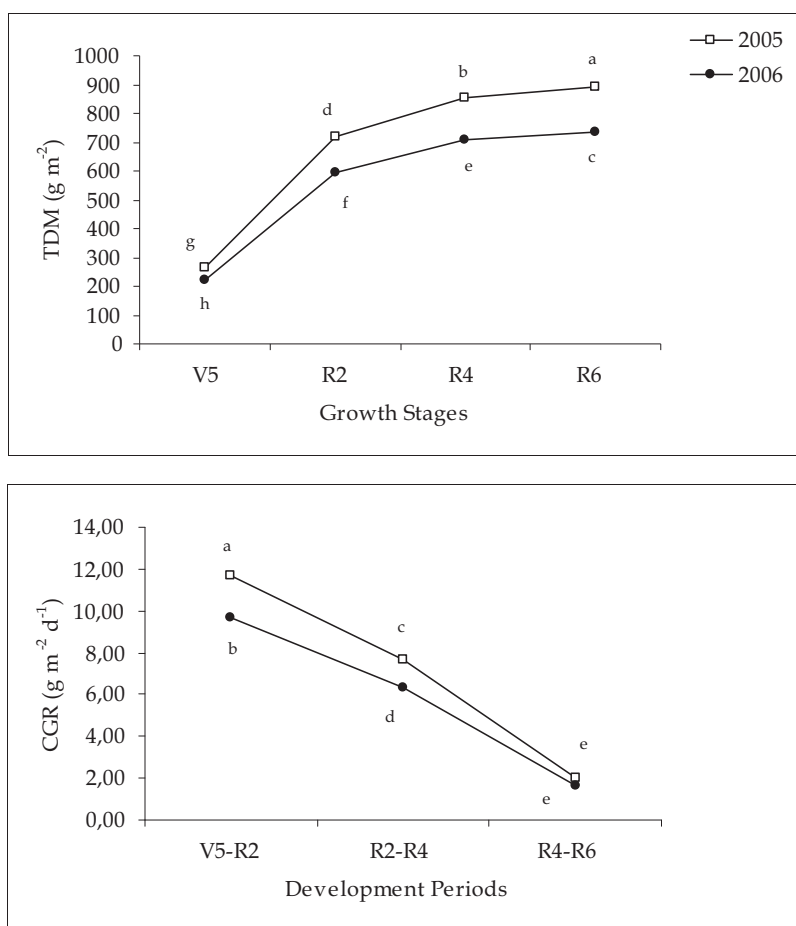

Fig. 3. Total dry matter (TDM) and crop growth rate (CGR) during growth stages and development periods for soybean planted in 2005 and 2006.

The total dry matter greatly increased during the V₅ to R₆ period in the mid-May planting, whereas these increases occurred during the V₅ to R₄ period in mid-April planting. TDM did not significantly increase at the R₆ stage (Figure 4). However, CGR decreased from 10.5-11.0 g m⁻² d⁻¹ in the V₅-R₂ period to 0.73 - 2.96 g m⁻² d⁻¹ in the R₄-R₆ period in each planting date. These decreases were statistically significant. Although differences in CGR between planting dates were not significant in the V₅-R₂ period, the mid-May planting date had greater CGR in the R₂-R₄ and R₄-R₆ periods than the mid-April planting (Figure 4). The highest CGR in both planting dates was obtained from the V₅-R₂ period. In both planting dates, however, a LAI of 3.0 was reached by R₂, and light interception was at an optimal level of 95% in R₂.

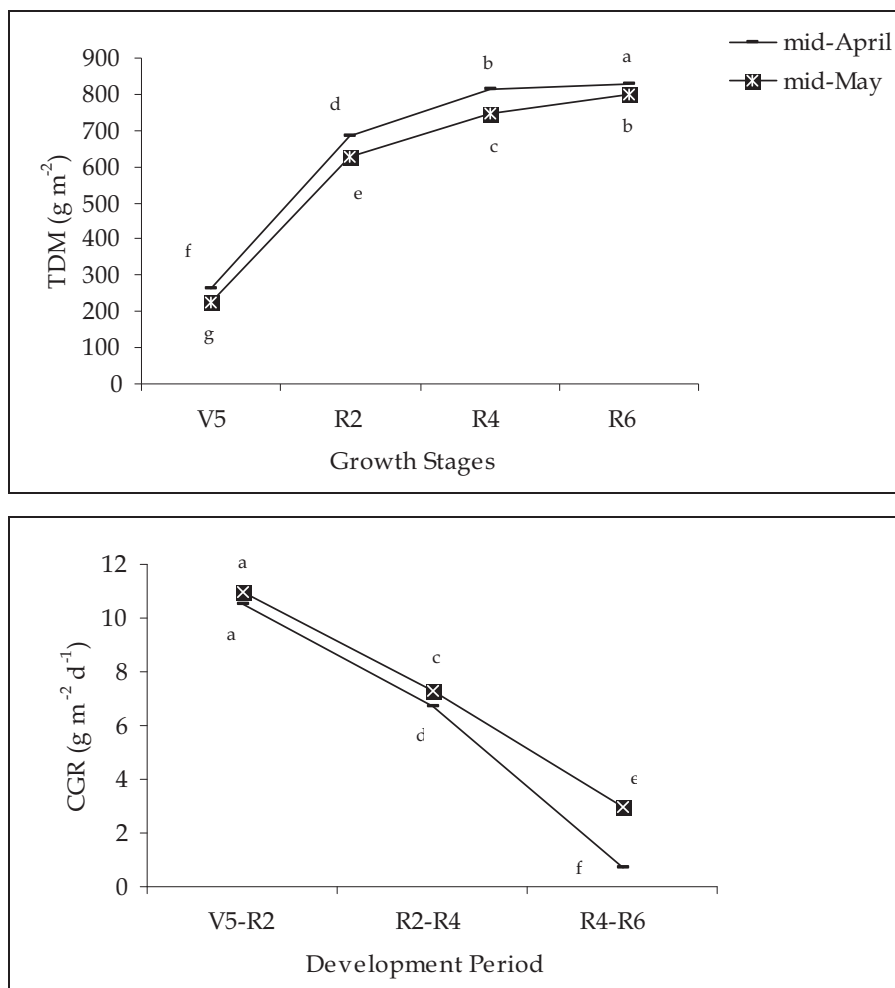

Fig. 4. Total dry matter (TDM) and crop growth rate (CGR) during growth stages and development periods for soybean planted in the mid-April and mid-May (2005-2006 combined data).

Total dry matter significantly increased during the V₅ to R₆ stages in each plant population, and these increases were always greater in the higher vs. lower plant populations during the same period. Crop growth rates significantly reduced from the V₅-R₂ period to R₄-R₆ period in each plant population (Figure 5).

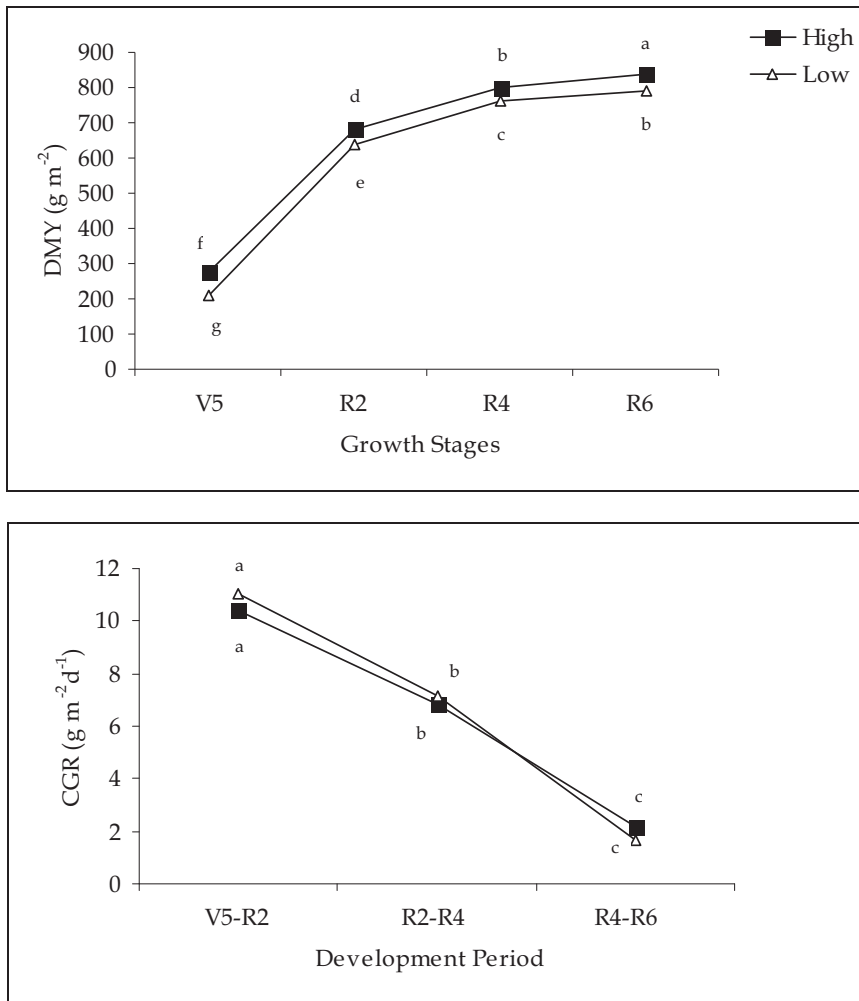

Fig. 5. Total dry matter (TDM) and crop growth rate (CGR) during growth stages and development periods for soybean grown at low and high plant populations (2005-2006 combined data).

Correlations between seed yield and LI, LAI, and TDM were positive and highly significant for all developmental stages in both planting dates. In addition, seed yield was positively and significantly associated with LI, LAI, and TDM for all plant population \times developmental stage treatment combinations except for the V₅ developmental stages at high and low plant populations. Positive and significant correlations were also found between seed yield and LI, LAI, and TDM for all cultivar \times developmental stage treatment combinations. In contrast, relationships between seed yield and LIE were mostly negative and significant, while the correlation between LI and LIE was not significant for most of the two-way treatment combinations (Table 6). Correlations between seed yield and CGR were nonsignificant for most two-way treatment combinations (Table 6).

Correlative relationships between LI with LAI and TDM were positive and significant ($P \leq 0.01$) for all developmental stages in each planting date. Correlations between LI and LAI were positively and highly significant for all plant population \times developmental stage treatment combinations, while relationships between LI and TDM were nonsignificant for only the V₅ stage in both plant populations. Also, LI was positively and significantly associated with LAI and TDM for all cultivar \times developmental stage treatments. On the other hand, correlations between LI and CGR were either nonsignificant or low for most treatment combinations (Table 6). Associations between LI and LIE were either negatively significant or nonsignificant for all treatment combinations (Table 6).

4. Discussion

Our data demonstrate that cultural practices affect developmental dynamics such as LAI, LI, LIE, CGR, and TDM in soybeans. Planting in mid-April resulted in significantly higher LAI and LIE than planting in mid-May, whereas LI was not affected by planting dates. LAI and LI increases were significantly greater in narrow rows (high plant populations) than wide rows (low plant populations). In contrast, LIE was significantly higher in wide rows (low plant populations) than narrow rows (high plant populations). Significant increases in LIE in the mid-April plantings were due to the insufficient shading effects of leaves because LAI was not high enough in the mid-April planting date. Late-maturity cultivar 1530 had higher LAI and LI but lower LIE than early-maturity cultivar A-3127. However, LAI was always suboptimum in both cultivars. The leaf area index significantly increased from the V₅ to the R₄ stages and reduced at the R₆ stage. Light interception greatly increased from the V₅ to the R₄ stage but decreased at the R₆ stage. In contrast, LIE significantly decreased from the vegetative development stage to the reproductive developmental stage. The leaf area index had suboptimum levels at the vegetative and early reproductive developmental stages, but they reached optimum levels at the reproductive development stages. Our findings do not correspond to those of Board and Harville (1992), who reported that significant increases in LIE in narrow compared with wide rows occurred only in the July planting date, when LAI was lower. Those authors noted that the mutual shading of leaves probably prevented any increase in LIE at the higher LAI of the May planting date.

In our study, the significant increase in LIE in the mid-April planting date was due to the insufficient shading effects of the leaves; this was because LAI was not high enough in the mid-April planting date. Our results were, however, partially in agreement with those of

| Treatment combination | | Correlation coefficient of seed yield with; | | | | | LAI |
|-----------------------|----------------|---|-----------|-----------|--------------------------|--|---------|
| | | LAI | LI (%) | LIE (%) | TDM (g m ⁻²) | CGR(gm ⁻² d ⁻¹) | |
| Mid-April | V ₅ | 0.812** | 0.849** | -0.466** | 0.953** | 0.254 ns | 0.980** |
| | R ₂ | 0.851** | 0.951** | -0.692** | 0.844** | 0.122 ns | 0.835** |
| | R ₄ | 0.939** | 0.892** | -0.723** | 0.814** | -0.005 ns | 0.834** |
| | R ₆ | 0.935** | 0.780** | -0.688** | 0.823** | 0.275 ns | 0.704** |
| Mid-May | V ₅ | 0.794** | 0.815** | -0.563** | 0.885** | 0.281 ns | 0.992** |
| | R ₂ | 0.827** | 0.880** | -0.652** | 0.879** | 0.226 ns | 0.670** |
| | R ₄ | 0.920** | 0.896** | -0.654** | 0.835** | 0.173 ns | 0.855** |
| | R ₆ | 0.907** | 0.758** | -0.608** | 0.861** | 0.404* | 0.642** |
| High population | V ₅ | -0.131 ns | -0.099 ns | 0.236 ns | 0.932** | 0.275 ns | 0.982** |
| | R ₂ | 0.425* | 0.622** | 0.169 ns | 0.920** | 0.160 ns | 0.867** |
| | R ₄ | 0.888** | 0.819** | -0.337 ns | 0.903** | -0.314 ns | 0.949** |
| | R ₆ | 0.916** | 0.894** | 0.197 ns | 0.817** | 0.089 ns | 0.995** |
| Low population | V ₅ | -0.044 ns | 0.096 ns | 0.505** | 0.855** | 0.520** | 0.973** |
| | R ₂ | 0.534** | 0.511** | -0.177 ns | 0.934** | 0.183 ns | 0.931** |
| | R ₄ | 0.945** | 0.925** | -0.283 ns | 0.931** | -0.220 ns | 0.930** |
| | R ₆ | 0.891** | 0.849** | -0.386* | 0.905** | 0.305 ns | 0.977** |
| A-3127 | V ₅ | 0.412* | 0.418* | -0.346* | 0.929** | 0.271 ns | 0.992** |
| | R ₂ | 0.626** | 0.663** | -0.512** | 0.881** | 0.171 ns | 0.752** |
| | R ₄ | 0.859** | 0.930** | -0.518** | 0.838** | -0.123 ns | 0.862** |
| | R ₆ | 0.943** | 0.812** | -0.524** | 0.802** | 0.171 ns | 0.756** |
| 1530 | V ₅ | 0.477** | 0.473** | -0.350* | 0.935** | 0.196 ns | 0.988** |
| | R ₂ | 0.709** | 0.734** | -0.599** | 0.847** | 0.196 ns | 0.754** |
| | R ₄ | 0.946** | 0.860** | -0.696** | 0.825** | -0.168 ns | 0.834** |
| | R ₆ | 0.967** | 0.799** | -0.687** | 0.805** | 0.110 ns | 0.793** |

*, **Significant at P= 0.05 and 0.01, respectively; ns: not significant.

Table 6. Coefficients of correlations of seed yield with all the other characteristics and coefficients of correlations of light interception (LI) with the other characteristics except seed yield at certain developmental stages for A-3127 and 1530 soybean cultivars planted at high and low plant populations in mid-April and mid-May.

Board (2000), who found that LAI and LI were higher in medium or high plant populations compared with low plant populations, and lower in high plant populations than low plant populations at R₁. Board and Harville (1992) reported that the planting date x row spacing interaction had highly significant effects on LIE, while the planting date x cultivar x row spacing interaction was highly significant for LI. In our study, although the year x developmental stage and year x plant population interactions were significant ($P \leq 0.01$) for LAI and LI, these interactions are not clear or explicable. However, the significant year x developmental stage interaction for LAI and LI reveal that increases in LAI and LI from the V₅ to R₄ were greater in 2005 than in 2006. Board and Harville (1992) reported the occurrence of a significant row spacing x developmental stage effect on LI ($P = 0.01$). The authors stated that narrow row width resulted in significantly higher LI at all developmental stages.

Soybeans planted in mid-April had significantly higher TDM, but lower CGR in those planted in mid-May. The high plant populations gave higher TDM than the low plant populations. In contrast, CGR was significantly lower in the high plant populations than the low plant populations. In addition, late-maturity cultivar 1530 had significantly higher TDM than early-maturity cultivar A-3127, whereas cv. 1530 produced lower CGR than cv. A-3127. Crop growth rates decreased greatly from 9.7-11.7 g m⁻²d⁻¹ in the V₅-R₂ period and to 1.7-2.0 g m⁻²d⁻¹ in the R₄-R₆ period in both years. The leaf area index for both planting dates was optimum (4.0) for a maximum LI of 95% by R₄, whereas LI and CGR at stage R₄ were less than optimal (95%). An earlier study has indicated that optimal CGR and yield result when LAI is optimal (3.0 to 3.5) for achieving an optimal light interception of 95% by R₅ (Shibles and Weber, 1966). Several studies have concluded that the relationship between LAI and optimal CGR vary with environmental conditions (Jeffers and Shibles, 1969). However, optimal LI during the vegetative and early reproductive periods were not required to maximize yield (Board and Harville, 1994). In our study, CGR for the R₂-R₄ period was not at an optimal level, although LAI and LI were at or near optimum for the R₂ and R₄ developmental stages in the high plant populations. These results were similar for low plant populations, except for LAI at the R₂ stage.

Seed yield was positively and significantly correlated with LI, LAI, and TDM for both planting date x developmental stage and plant population x developmental stage treatment combinations. Correlations between seed yield and CGR were nonsignificant, while seed yield was negatively associated with LIE for most of the two-way treatment combinations. LI was positively and significantly associated with LAI and TDM for all of the two-way treatment combinations, whereas correlations between LI with CGR and LIE were nonsignificant for most treatment combinations. Earlier studies reported that soybean yield is positively related to LAI and dry matter at the R₅ stage (Wells *et al.*, 1982; Board and Tan, 1995; Kumudi, 2002; Liu *et al.*, 2005). In addition, the results of Shibles and Weber (1966) demonstrated that seed yield is highly associated with LAI, LI, and CGR. On the other hand, our findings are in agreement with those of Carpenter and Board (1997) who reported that as LAI increased, LIE decreased due to the mutual shading of leaves.

5. Conclusions

Plant population per unit area and growth dynamics such as LAI, LI, LIE, TDM and CGR are major predictors of soybean yield. In our study, planting in mid-April resulted in

significantly higher LAI, LIE, and TDM but lower CGR compared with the mid-May planting. Light interception (LI) was not affected by planting dates. Leaf area index (LAI), TDM, and LI increases were significantly greater in the narrow rows (high plant populations) than the wide rows (low plant populations). In contrast, LIE and CGR were significantly higher in the wide rows (low plant populations) than in the high plant populations (narrow rows). Late-maturity cultivar 1530 had higher LAI, LI, and TDM but lower LIE and CGR than early-maturity cultivar A-3127. Seed yield was positively and significantly correlated with LI, LAI, and TDM for most of the treatment combinations.

Our research group has also in work to determinate the associations between soybean yield and growth dynamics, intending in future to make different studies.

6. Acknowledgements

This research work was supported by The Commission of Scientific Research Projects of Uludag University (Project No: 2003/91; Project Leader: Prof. Dr. A. Tanju Goksoy).

7. References

- Ball, R.A.; Purcell, L.C. & Vories, E.D. (2000a). Optimizing soybean plant population for a short-season production system in the southern USA. *Crop Science*, 40(3): 757-764. ISSN: 0011-183X.
- Ball, R.A.; Purcell, L.C. & Vories, E.D. (2000b). Short-season soybean yield compensation in response to population and water regime. *Crop Science*, 40(4): 1070-1078. ISSN: 0011-183X.
- Beatty, K.D.; Eldridge, I.L. & Simpson, A.M. (1982). Soybean response to different planting patterns and dates. *Agronomy Journal*, 74(5): 859- 862. ISSN: 0002-1962.
- Board, J.E.; Harville, B.G. & Saxton, A.M. (1990). Narrow-row seed-yield enhancement in determinate soybean. *Agronomy Journal*, 82(1): 64-68. ISSN: 0002-1962.
- Board, J.E. & Harville, B.G. (1992). Explanations for greater light interception in narrow- vs. wide-row soybean. *Crop Science*, 32(1): 198-202. ISSN: 0011-183X.
- Board, J.E.; Kamal, M. & Harville, B.G. (1992). Temporal importance of greater light interception to increased yield in narrow-row soybean. *Agronomy Journal*, 84(4): 575-579. ISSN: 0002-1962.
- Board, J.E. & Harville, B.G. (1993). Soybean yield component responses to a light interception gradient during the reproductive period. *Crop Science*, 33(4): 772-777. ISSN: 0011-183X.
- Board, J.E. & Harville, B.G. (1994). A criterion for acceptance of narrow-row culture in soybean. *Agronomy Journal*, 86(6): 1103-1106. ISSN: 0002-1962.
- Board, J.E. & Tan, Q. (1995). Assimilatory capacity effects on soybean yield components and pod number. *Crop Science*, 35(3): 846-851. ISSN: 0011-183X.
- Board, J. (2000). Light interception efficiency and light quality affect yield compensation of soybean at low plant population. *Crop Science*, 40(5): 1285-1294. ISSN: 0011-183X.

- Boerma H.R. & Ashley D.A. (1982). Irrigation, row spacing, and genotype effects on late and ultra-late planted soybeans. *Agronomy Journal*, 74(6): 995-998. ISSN: 0002-1962.
- Boquet, D.J.; Koonce, K.L. & Walker, D.M. (1982). Selected determinate soybean cultivar yield response to row spacings and planting dates. *Agronomy Journal*, 74(1): 136-138. ISSN: 0002-1962.
- Bullock, D.; Khan, S. & Rayburn, A. (1998). Soybean yield response to narrow rows is largely due to enhanced early growth. *Crop Science*, 38(4): 1011-1016. ISSN: 0011-183X.
- Carpenter, A.C. & Board, J.E. (1997). Branch yield components controlling soybean yield stability across plant populations. *Crop Science*, 37(3): 885-891. ISSN: 0011-183X.
- Carter, T.E. & Boerma, H.R. (1979). Implications of genotype x planting date and row spacing interactions in double-cropped soybean cultivar development. *Crop Science*, 19(5): 607-610. ISSN: 0011-183X.
- Costa, J.A.; Oplinger, E.S. & Pendleton, J.W. (1980). Response of soybean cultivars to planting patterns. *Agronomy Journal*, 72(1): 153-156. ISSN: 0002-1962.
- Duncan, W.G. (1986). Planting patterns and soybean yields. *Crop Science*, 26(3): 584-588. ISSN: 0011-183X.
- Egli, D.B.; Leggett, J.E. & Wood, J.M. (1978). Influence of soybean seed size and position on the rate and duration of filling. *Agronomy Journal*, 70(1): 127-130. ISSN: 0002-1962.
- Egli, D.B. (1988). Plant density and soybean yield. *Crop Science*, 28(6): 977-981. ISSN: 0011-183X.
- Egli, D.B. (1993). Cultivar maturity and potential yield of soybean. *Field Crops Research*, 32(1-2): 147-158. ISSN: 0378-4290.
- Egli, D.B. & Bruening, W.P. (2000). Potential of early-maturing soybean cultivars in late plantings. *Agronomy Journal*, 92(3): 532-537. ISSN: 0002-1962.
- Ennin, S.A. & Clegg, M.D. (2001). Effect of soybean plant populations in a soybean and maize rotation. *Agronomy Journal*, 93(2): 396-403. ISSN: 0002-1962.
- Fehr, W.R. & Caviness, C.E. (1977). Stages of soybean development. Iowa Agric. Home Econ. Exp. Sta., Iowa Coop. Ext. Serv. Spec. Re. 80.
- Herbert S.J. & Litchfield G.U. (1984). Growth response of short season soybean to variations in row spacing and density. *Field Crops Research*, 9(1): 163-171. ISSN: 0378-4290.
- Holshouser, D.L. & Whittaker, J.P. (2002). Plant population and row spacing effects on early soybean production systems in the mid Atlantic USA. *Agronomy Journal*, 94(3): 603-611. ISSN: 0002-1962.
- Hunt R. (1978). Plant growth analysis. Southampton, UK: Camelot Press, Inst. Biol. Stud. Biol. 96.
- Hunt, R. (1982). Plant growth curves: The functional approach to plant growth analysis. Arnold, London, and Univ. Park Press, Baltimore, MD.

- Jeffers D.L. & Shibles R.M. (1969). Some effects of leaf area, solar radiation, air temperature, and variety on net photosynthesis in field-grown soybeans. *Crop Science*, 9(6): 762-764. ISSN: 0011-183X.
- Jensen, M.E. (Ed.). (1980). Design and Operation of Farm Irrigation Systems. Amer. Soc. Agric. Engr. St. Joseph, MI. 829 pgs.
- Kane, M.V. & Grabau, L.J. (1992). Early planted, early maturing soybean cropping system: Growth, development, and yield. *Agronomy Journal*, 84(5): 769-773.
- Kumudi, S. (2002). Trials and tribulations: a review of the role of assimilate supply in soybean genetic yield improvement. *Field Crops Research*, 75(2-3): 211-222. ISSN: 0378-4290.
- Liu, X.B.; Jin, J.; Herbert, S.J.; Zhang Q.Y. & Wang G.H. (2005). Yield components, dry matter, LAI, and LAD of soybeans in Northeast China. *Field Crops Research*, 93(1): 85-93. ISSN: 0378-4290.
- Loomis, R.S. & Connor, D.J. (1992). Community concepts. In: *Crop Ecology: Productivity and Management in Agricultural Systems*. pp. 32-59. Cambridge Univ. Press, Cambridge, UK. ISBN:0-521.38379-X.
- Parker, M.B.; Marchant, W.H. & Mullinix, B.J., Jr. (1981). Date of planting and row spacing effects on four soybean cultivars. *Agronomy Journal*, 73(5): 759-762. ISSN: 0002-1962.
- Parks, W.L.; Davis, J.; Evans, R.; Smith, M.; Mccutchen, T.; Sofley, L. & Sanders, W. (1982). Soybean yields as affected by row spacing and within row plant density. Univ. of Tenn. Agric. Exp. Stn. Bull. 615. Knoxville, TN.
- Pedersen, P. & Lauer, J.G. (2004). Response of soybean yield components to management system and planting date. *Agronomy Journal*, 96(5): 1372-1381. ISSN: 0002-1962.
- Purcell, L.C.; Ball, R.A.; Reaper, J.D. & Vories, E.D. (2002). Radiation use efficiency and biomass production in soybean at different plant population densities. *Crop Science*, 42(1): 172-177. ISSN: 0011-183X.
- Sas Institute, (1989). SAS/STAT user's guide. Version 6 edition. Cary, NC: SAS Institute, Cary, NC.
- Shibles, R.M. & Weber, C.R. (1966). Interception of solar radiation and dry matter production by various soybean planting patterns. *Crop Science*, 6(1): 55-59. ISSN: 0011-183X.
- Weber, C.R.; Shibles, R.M. & Byth, D.E. (1966). Effect of plant population and row spacing on soybean development and production. *Agronomy Journal*, 58(1): 99-102. ISSN: 0002-1962.
- Wells, R.; Schulze, L.L.; Ashley, D.A.; Boerma, H.R. & Brown, R.H. (1982). Cultivar differences in canopy apparent photosynthesis and their relationship to seed yield in soybeans. *Crop Science*, 22(4): 886-890. ISSN: 0011-183X.
- Wells, R. (1991). Soybean growth response to plant density: relationship among canopy photosynthesis, leaf area, and light interception. *Crop Science*, 31(3): 755-761. ISSN: 0011-183X.
- Wells, R. (1993). Dynamics of soybean growth in variable planting patterns. *Agronomy Journal*, 85(1): 44-48. ISSN: 0002-1962.

Westgate, M.E. (1999). Managing soybeans for photosynthetic efficiency. In: H.E. Kauffman (Ed.) World Soybean Research. Proc. World Soybean Res. Conf., 6th, Chicago, IL. 4-7 Aug. 1999. Supehybrid rior Printing, Champaign, IL.

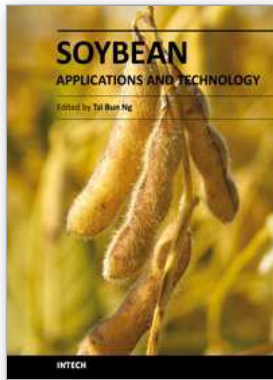

Soybean - Applications and Technology

Edited by Prof. Tzi-Bun Ng

ISBN 978-953-307-207-4

Hard cover, 402 pages

Publisher InTech

Published online 26, April, 2011

Published in print edition April, 2011

Soybean is an agricultural crop of tremendous economic importance. Soybean and food items derived from it form dietary components of numerous people, especially those living in the Orient. The health benefits of soybean have attracted the attention of nutritionists as well as common people.

How to reference

In order to correctly reference this scholarly work, feel free to copy and paste the following:

Mehmet Sincik, A. Tanju Göksoy and Z. Metin Turan (2011). How Growth Dynamics Affect Soybean Development across Cultural Practices, Soybean - Applications and Technology, Prof. Tzi-Bun Ng (Ed.), ISBN: 978-953-307-207-4, InTech, Available from: <http://www.intechopen.com/books/soybean-applications-and-technology/how-growth-dynamics-affect-soybean-development-across-cultural-practices>

INTECH

open science | open minds

InTech Europe

University Campus STeP Ri
Slavka Krautzeka 83/A
51000 Rijeka, Croatia
Phone: +385 (51) 770 447
Fax: +385 (51) 686 166
www.intechopen.com

InTech China

Unit 405, Office Block, Hotel Equatorial Shanghai
No.65, Yan An Road (West), Shanghai, 200040, China
中国上海市延安西路65号上海国际贵都大饭店办公楼405单元
Phone: +86-21-62489820
Fax: +86-21-62489821

© 2011 The Author(s). Licensee IntechOpen. This chapter is distributed under the terms of the [Creative Commons Attribution-NonCommercial-ShareAlike-3.0 License](#), which permits use, distribution and reproduction for non-commercial purposes, provided the original is properly cited and derivative works building on this content are distributed under the same license.

Optimization of the Technology for Preparing Soluble Dietary Fiber from Extruded Soybean Residue

Yujie Chi

¹College of Food Science, Northeast Agricultural University, Harbin 150030

²Educational Ministry and Provincial Key Laboratory for Soybean Biology Harbin 150030
China

1. Introduction

It is well known that dietary fiber plays an important role in many physiological processes and in the prevention of diseases of different origin (Rodriguez et al., 2006; Champ et al., 2000). According to the solubility in water, total dietary fiber (TDF) can be categorized into two groups, namely soluble (SDF) and insoluble (IDF) dietary fiber. SDF and IDF have been known to play different physiological roles in human health (Vasanthan et al., 2002; Burlcitt et al., 1974). SDF appears to be more effective than IDF in many healthy aspects. Therefore, preparation of SDF is especially important.

China is origin of soybean, and soybean production has been highest in the world. China's consumption of soybean products is considerable. However, a large number of by-products that is soybean residue would be produced in soybean processing. Previously, most of soybean residue only was used as feed or fertilizer. Its practical value was not fully utilized. Soybean residue is a good dietary fiber resource (Bourquin et al., 1996; Tharanathan et al., 2003). The content of total dietary fiber in soybean residue is about 60% (Zheng et al., 2005; Jiang et al., 2001). It has a broad development prospects. There are many methods that can be used to prepare SDF, such as acid (Wang et al., 2004), alkaline (Wang et al., 2004; Zheng et al., 2008), enzymatic (Liu et al., 2008), fermentation (Tu et al., 2007), mechanical method (Tu et al., 2007; Jin et al., 1996) and the combined method (Xu et al., 2005; Tu et al., 2008) and so on, but the raw materials were processed without extrusion residue. The extruded soybean residue as raw material was treated with alkali, which has not been previously reported. The present research is to optimize the conditions of SDF preparation. The high yield of SDF will be prepared under the optimal conditions.

2. Materials and methods

2.1 Materials

Soybean residue was supplied by bean products factory of Northeast Agricultural University (Harbin, China). Heat stable α -amylase, Protease and amyloglucosidase were obtained from Sigma Chemical Company. All the other reagents were of analytical grade.

2.2 Sample preparation

Fresh soybean residue was dried overnight in an oven at temperature of 60°C. Then the dried soybean residue was ground using an electric grinder and sieved through 0.425mm mesh. The ground soybean residue was extruded by a single-screw extruder. The conditions of extrusion were the following: feed moisture approximately 20%, mass temperature approximately 160°C, screw speed approximately 175rpm and a diameter of 10 mm. The extruded soybean residue was ground and sieved through 0.425mm mesh. The extruded soybean residue was used for alkali treatment.

2.3 Alkali treatment

Twenty grams of soybean residue or extruded soybean residue were mixed with 400 ~ 560mL concentration of 0.40 ~ 1.20% (W/V) NaOH solution. The slurries containing NaOH were incubated in a water bath for a selected period of time (40 ~ 80min) at different temperature (70 ~ 90°C). The alkali treatment variables are presented in table 1. After neutralization with 6mol/L HCL, the resultant suspensions were centrifugated at 3000g for 20min, and the supernatants were added four times the volume of 95% ethanol. Let precipitate form at room temperature 1h. The SDF was obtained after centrifugation (3000g, 10min), and was dried at 60°C. Soybean residue or extruded soybean residue was treated with alkali in the same conditions, the yields of SDF were compared.

| Independent variable | Symbol | | Levels | | | | |
|--------------------------|----------------|----------------|--------|--------|--------|--------|--------|
| | Uncodified | Codified | -2 | -1 | 0 | +1 | +2 |
| Ratio of liquid to solid | X ₁ | x ₁ | 20 : 1 | 22 : 1 | 24 : 1 | 26 : 1 | 28 : 1 |
| Temperature (°C) | X ₂ | x ₂ | 70 | 75 | 80 | 85 | 90 |
| Time (h) | X ₃ | x ₃ | 40 | 50 | 60 | 70 | 80 |
| Alkali concentration (%) | X ₄ | x ₄ | 0.40 | 0.60 | 0.80 | 1.00 | 1.20 |

Table 1. Independent variables and their levels used for the central composite design and optimization of alkali treatment conditions

2.4 The yield of soluble dietary fiber determination

The SDF content of the precipitate was determined using the Enzymatic-Gravimetric method (Lee et al., 1992). The yield of SDF was expressed as:

$$\text{Yield of SDF (\%)} = \frac{\text{dry weight of precipitate(g)} \times \text{content of SDF(\%)}}{\text{weight of soybean residue or extruded soybean residue(g)}} \times 100\% \quad (1)$$

2.5 Experimental design

A statistical tool utilizing five levels, four variables and central composite design, with 31 individual points, was employed to study the effects of alkali treatment on SDF preparation from extruded soybean residue. The independent variables and their levels were selected, based on the preliminary experiments in our laboratory (data not shown). The independent variables X_i were coded as x_i, which are defined as dimensionless, according to the Eq.(2):

$$x_i = (X_i - X_0) / \Delta X_i \tag{2}$$

Where x_i is the coded value of an independent variable, X_i is the real value of an independent variable, X_0 is the real value of an independent variable at the centre point, and ΔX_i is the step change value. The independent variables and their levels are presented in Table 2. The 31 runs were performed in a totally random order to minimize bias. Each experiment had two replications and the average prepared SDF was taken as the response, Y. The responses generated from the experiment are presented in Table 3.

| Run | Independent variables ^b | | | | Response(Y) ^c |
|-----|------------------------------------|-------|-------|-------|--------------------------|
| | x_1 | x_2 | x_3 | x_4 | |
| 1 | -1 | -1 | -1 | -1 | 22.05 |
| 2 | 1 | -1 | -1 | -1 | 23.47 |
| 3 | -1 | 1 | -1 | -1 | 22.86 |
| 4 | 1 | 1 | -1 | -1 | 24.59 |
| 5 | -1 | -1 | 1 | -1 | 23.91 |
| 6 | 1 | -1 | 1 | -1 | 24.55 |
| 7 | -1 | 1 | 1 | -1 | 25.46 |
| 8 | 1 | 1 | 1 | -1 | 26.58 |
| 9 | -1 | -1 | -1 | 1 | 23.62 |
| 10 | 1 | -1 | -1 | 1 | 25.63 |
| 11 | -1 | 1 | -1 | 1 | 25.03 |
| 12 | 1 | 1 | -1 | 1 | 27.62 |
| 13 | -1 | -1 | 1 | 1 | 26.24 |
| 14 | 1 | -1 | 1 | 1 | 27.51 |
| 15 | -1 | 1 | 1 | 1 | 30.27 |
| 16 | 1 | 1 | 1 | 1 | 32.16 |
| 17 | -2 | 0 | 0 | 0 | 23.85 |
| 18 | 2 | 0 | 0 | 0 | 27.07 |
| 19 | 0 | -2 | 0 | 0 | 23.55 |
| 20 | 0 | 2 | 0 | 0 | 28.56 |
| 21 | 0 | 0 | -2 | 0 | 22.32 |
| 22 | 0 | 0 | 2 | 0 | 28.23 |
| 23 | 0 | 0 | 0 | -2 | 21.34 |
| 24 | 0 | 0 | 0 | 2 | 27.93 |
| 25 | 0 | 0 | 0 | 0 | 26.17 |
| 26 | 0 | 0 | 0 | 0 | 26.65 |
| 27 | 0 | 0 | 0 | 0 | 26.77 |
| 28 | 0 | 0 | 0 | 0 | 26.68 |
| 29 | 0 | 0 | 0 | 0 | 25.73 |
| 30 | 0 | 0 | 0 | 0 | 26.94 |
| 31 | 0 | 0 | 0 | 0 | 26.09 |

^a Non-randomized.

^b Coded symbols and levels of independent variables refer to Table 1.

^c Averages of duplicated determination from different experiments.

Table 2. Central composite design and responses a

| Source | Sum of squares | Degrees of freedom | Mean square | F-value | P-value | Significance |
|--------------------|-----------------|--------------------|-----------------|-----------------|--------------------|-----------------------|
| Model | 169.2204 | 14 | 12.08717 | 65.10984 | < 0.0001 | significant |
| x_1 | 15.21634 | 1 | 15.21634 | 81.96568 | < 0.0001 | significant |
| x_2 | 31.763 | 1 | 31.763 | 171.0974 | < 0.0001 | significant |
| x_3 | 47.12404 | 1 | 47.12404 | 253.8426 | < 0.0001 | significant |
| x_4 | 59.5035 | 1 | 59.5035 | 320.5269 | < 0.0001 | significant |
| x_1x_2 | 0.247506 | 1 | 0.247506 | 1.333239 | 0.2652 | nonsignificant |
| x_1x_3 | 0.500556 | 1 | 0.500556 | 2.696341 | 0.1201 | nonsignificant |
| x_1x_4 | 0.507656 | 1 | 0.507656 | 2.734587 | 0.1177 | nonsignificant |
| x_2x_3 | 3.001556 | 1 | 3.001556 | 16.16845 | 0.0010 | significant |
| x_2x_4 | 2.697806 | 1 | 2.697806 | 14.53224 | 0.0015 | significant |
| x_3x_4 | 2.847656 | 1 | 2.847656 | 15.33944 | 0.0012 | significant |
| x_1^2 | 0.950089 | 1 | 0.950089 | 5.117832 | 0.0380 | significant |
| x_2^2 | 0.032143 | 1 | 0.032143 | 0.173144 | 0.6829 | nonsignificant |
| x_3^2 | 1.493398 | 1 | 1.493398 | 8.044472 | 0.0119 | significant |
| x_4^2 | 4.316615 | 1 | 4.316615 | 23.25227 | 0.0002 | significant |
| Residual | 2.970285 | 16 | 0.185643 | | | |
| Lack of Fit | 1.810542 | 10 | 0.181054 | 0.936695 | 0.5591 | nonsignificant |
| Pure Error | 1.159743 | 6 | 0.19329 | | | |
| Cor. Total | 172.1907 | 30 | | | | |

"Prob>F"<0.0500 significant; "Prob>F">0.0500 nonsignificant.

Table 3. Analysis of variance (ANOVA) of the regression parameters for the response surface model

2.6 Statistical analysis

The response surface regression (RSREG) procedure of the Design Expert (Version 7.1.3, Stat-Ease Inc., Minneapolis, Minnesota, USA) was used to fit the experimental data to the second-order polynomial equation to obtain coefficients of the Eq. (3).

$$Y = \beta_0 + \sum_{i=1}^4 \beta_{ixi} + \sum_{i=1}^4 \beta_{ii} x_i^2 + \sum_{i=1}^3 \sum_{j=i+1}^4 \beta_{ij} x_i x_j \quad (3)$$

Where Y is the response variable, x_i and x_j are the coded independent variables, and β_0 , β_i , β_{ii} and β_{ij} are the regression coefficients of variables for intercept, linear, quadratic and interaction regression terms, respectively. The analysis of variance (ANOVA) tables were generated, and the effect and regression coefficients of individual linear, quadratic and interaction terms were determined. The significance of each coefficient in the polynomial was tested using an F-test. The regression coefficients were used for statistical calculations to generate response surfaces and contour plots.

2.7 Verification of model

The optimal conditions of alkali treatment depended on ratio of liquid to solid, temperature, incubation time and alkali concentration, and were obtained using RSM. For verification of

the model, the SDF was prepared under optimal conditions and the prepared SDF was determined. The experimental and predicted values were compared in order to determine the validity of the model.

3. Results and discussion

3.1 Comparison of the yields of SDF

Soybean residue or extruded soybean residue was treated with alkali in the same conditions (a ratio of liquid to solid 24 : 1, a temperature of 80°C, a processing time of 60min and an alkali concentration of 0.80%), the yields of SDF were compared in Table 4.

| Raw materials | Yield of SDF ^a / % |
|--------------------------|-------------------------------|
| Soybean residue | 10.16±0.09 |
| Extruded soybean residue | 26.36±0.55 |

^a Values are means±SD (n=4)

Table 4. Comparison of the yields of SDF

The results indicated that the yield of SDF prepared from extruded soybean residue was significantly higher than the yield of SDF prepared from soybean residue. The structure of dietary fiber was changed while the raw materials were extruded. Therefore, the conditions of SDF prepared from extruded soybean residue should be optimized in order to increase the yield of SDF.

3.2 Fitting the models

The study utilized RSM to develop a prediction model for optimizing the alkali treatment conditions of SDF prepared from extruded soybean residue. The experimental conditions and the corresponding response values from the experimental design are presented in Table 2. The independent and dependent variables were analyzed to obtain a regression equation that could predict the responses within the given range. The regression equation for SDF preparation (Y) is as follows:

$$Y = 32.17125 + 1.76482x_1 - 0.70210x_2 - 0.23514x_3 - 32.77976x_4 + 0.012438x_1x_2 - 0.00884375x_1x_3 + 0.44531x_1x_4 + 0.0086625x_2x_3 + 0.41063x_2x_4 + 0.21094x_3x_4 - 0.045569x_1^2 - 0.00134107x_2^2 - 0.00228527x_3^2 - 9.71317x_4^2 \quad (4)$$

The plot of experimental values of prepared SDF (%) versus those calculated from Eq. (4) indicated a good fit, as presented in Fig. 1.

The results of analysis of variance (ANOVA) for the CCD are shown in Table 3. For the model fitted, the coefficient of determination (R^2), which is a measure of degree of fit. Joglekar and May (1987) suggested that, for a good fit of a model, R^2 should be at least 0.80. The coefficient of determination (R^2) was 0.983. This implies that 98.3% of the variations could be explained by the fitted model. The probability (P) value of the regression model significance was less than 0.001. Therefore, the developed model could adequately represent the real relationship among the parameters chosen. A regression analysis was carried out to fit mathematical models to the experimental data aiming at an optimal region for the responses studied. Some nonsignificant terms were neglected, and the predicted model was

not refitted. The predicted model can be described by the following equation in terms of coded values:

$$Y = 21.72394 + 2.54265x_1 - 0.61817x_2 - 0.45167x_3 - 22.23493x_4 + 0.0086625x_2x_3 + 0.41063x_2x_4 + 0.21094x_3x_4 - 0.044678x_1^2 - 0.0022496x_3^2 - 9.62400x_4^2 \quad (5)$$

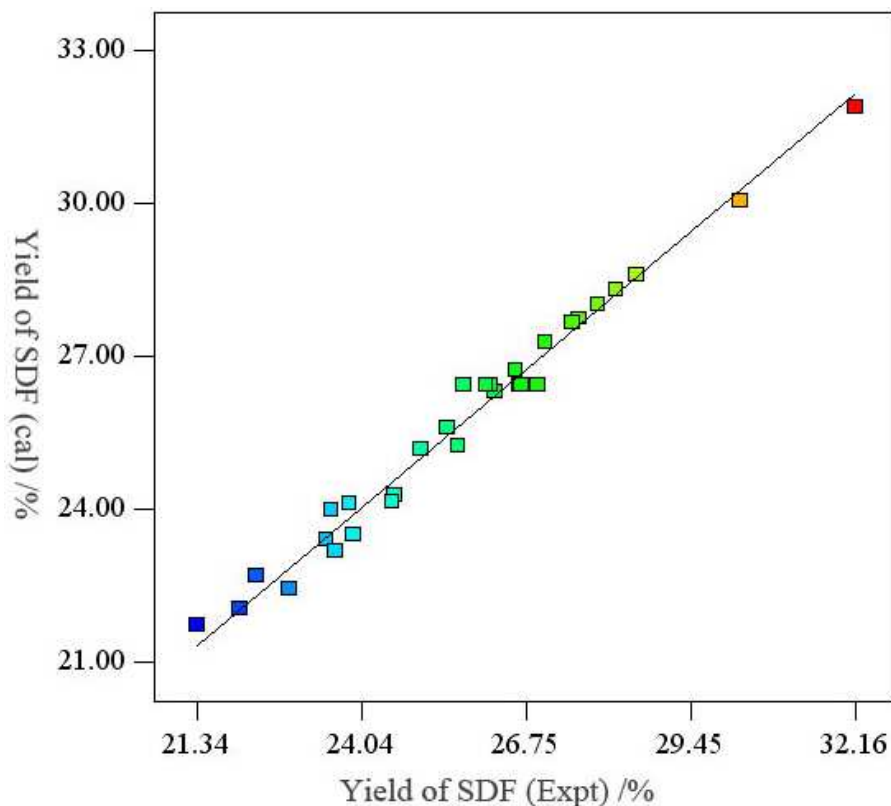

Fig. 1. Correlation of predicted SDF with experimental prepared SDF

3.3 Effects of independent variables on responses

The significance of each coefficient was determined using the F-test and p-value. The corresponding variables would be more significant if the absolute F-value becomes greater and the p-value becomes smaller (Atkinson et al., 1992). It can be seen that the variables with the largest effect were the linear terms of x_1 , x_2 , x_3 , x_4 and the quadratic terms of x_1^2 , x_3^2 , x_4^2 , followed by the interaction effects of x_2x_3 , x_2x_4 , x_3x_4 . The results indicated that the effects order of the linear terms on the yield of SDF were as follows: alkali concentration (x_4), ratio of liquid to solid (x_1), temperature (x_2) and time (x_3). To aid visualization, the response surfaces and contour plots of alkali treatment conditions are shown in Figs. 2-7.

A positive relation was found between the ratio of liquid to solid and the yield of SDF (Figs. 2, 3 and 4). The yield of SDF was increased with the increase of ratio of liquid to solid, especially when the ratio of liquid to solid was within the range of 20-26. Though a further increase was shown when the ratio of liquid to solid was more than 26, it was very slight. The effect of temperature on the yield of SDF is shown in Figs. 2, 5 and 6. The effect of temperature on the yield of SDF was similar to the ratio of liquid to solid. The response surface and contour plots of the effects of temperature was presented in Figs. 2, 5 and 6. The yield of SDF was increased with the increase of temperature in this study. The yield of SDF was increased with the extension of time, especially when the time was within the range of 40-65min. Though a further improvement was shown when the time was longer than 65min, it was very slight. The effect of alkali concentration on the yield of SDF is shown in Figs. 4, 6 and 7. The yield of SDF was increased with the increase of alkali concentration, especially when the alkali concentration was within the range of 0.40-1.00%. Though a further increase was shown when the alkali concentration was more than 1.00%, it was very slight.

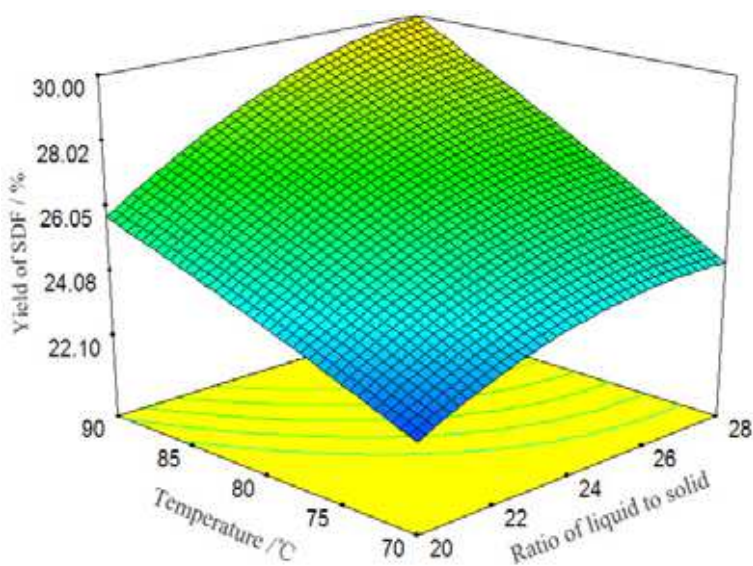

Fig. 2. Response surface for effects of ration of liquid to solid and temperature on the yield of SDF

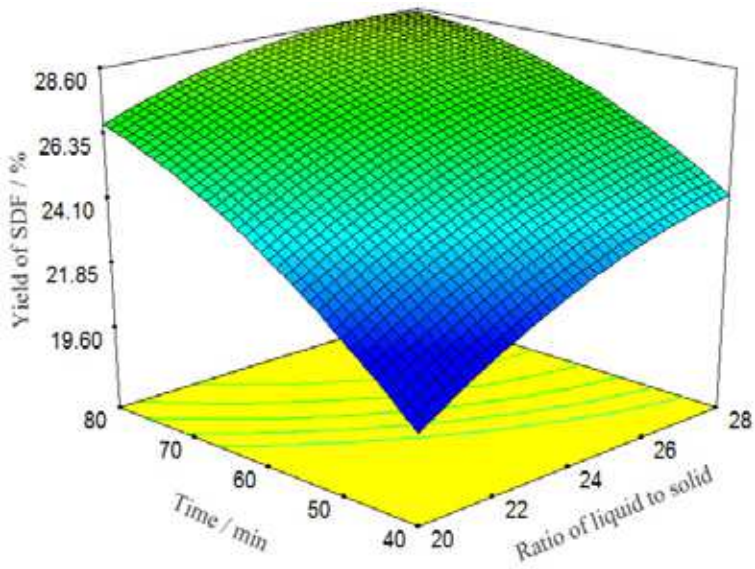

Fig. 3. Response surface for effects of ration of liquid to solid and time on the yield of SDF

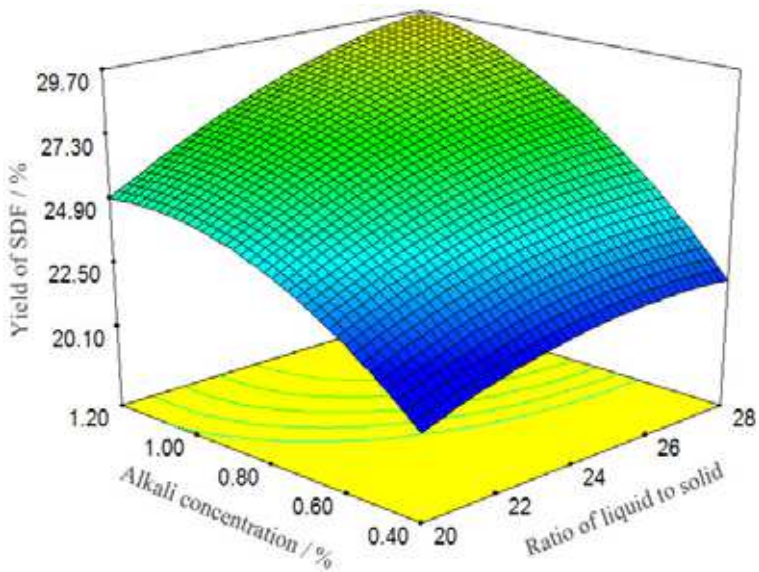

Fig. 4. Response surface for effects of ration of liquid to solid and alkali concentration on the yield of SDF

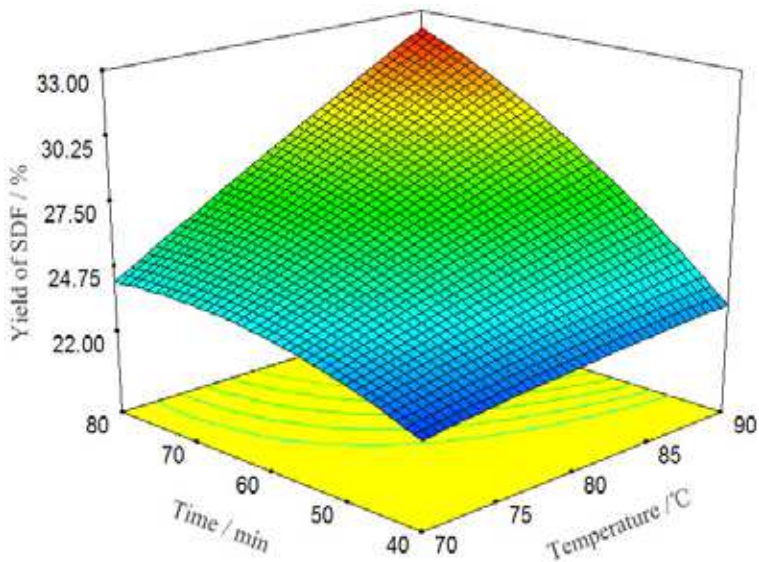

Fig. 5. Response surface for effects of temperature and time on the yield of SDF

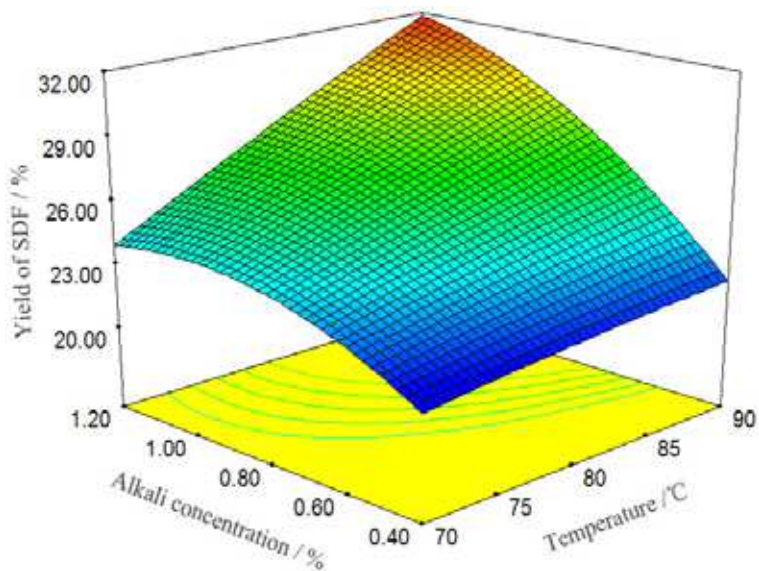

Fig. 6. Response surface for effects of temperature and alkali concentration on the yield of SDF

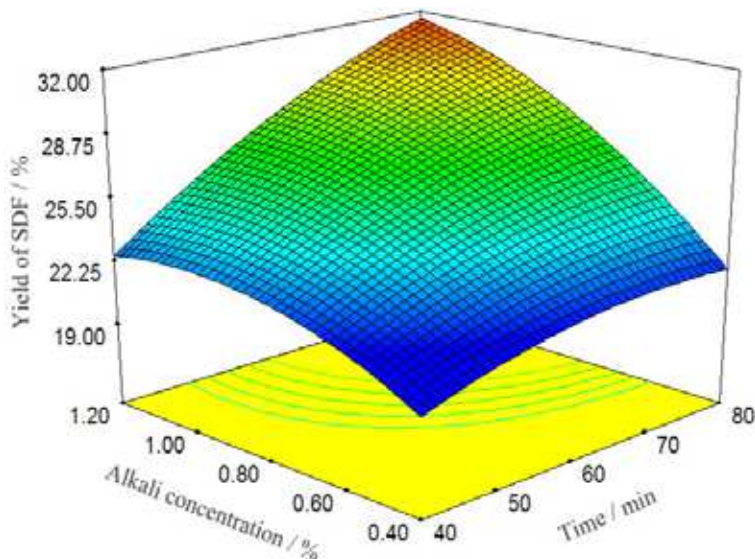

Fig. 7. Response surface for effects of time and alkali concentration on the yield of SDF

3.4 Optimization conditions and model verification

From the model, optimal conditions for alkali treatment of SDF preparation were obtained as follow: a ratio of liquid to solid 26 : 1, a temperature of 89°C, a processing time of 68min and an alkali concentration of 1.12%. Under optimal conditions, a maximum response of 33.96% SDF was predicted. The suitability of the model equation for predicting the optimum response value was tested by additional independent experiments under the optimal conditions. The results indicated that the experimental SDF value (34.12%) was not significantly different from the predicted SDF value (33.96%). The yield of SDF prepared from soybean residue was 13.51% under the optimal conditions. After alkali treatment, comparing the yield of SDF (34.12%) prepared from extruded soybean residue with the yield of SDF (13.51%) prepared from soybean residue, the yield of SDF prepared from extruded soybean residue was significantly more than the yield of SDF prepared from soybean residue under the optimal conditions.

4. Conclusions

The yield of SDF (26.36%) prepared from extruded soybean residue was higher than the yield of SDF (10.16%) prepared from soybean residue under the conditions (a ratio of liquid to solid 24 : 1, a temperature of 80°C, a processing time of 60min and an alkali concentration of 0.80%). The effects order of the linear terms on the yield of SDF was as follows: alkali concentration, ratio of liquid to solid, temperature and time. The optimal conditions for the yield of soluble dietary fiber prepared from extruded soybean residue were: a ratio of liquid to solid 26 : 1, a temperature of 89°C, a processing time of 68min and an alkali concentration of 1.12%. Under optimal conditions, the yield of soluble dietary fiber prepared from extruded soybean residue was 34.12%, significantly higher than the yield of soluble dietary fiber prepared from soybean residue.

5. References

- Atkinson AC, Donev AN, 1992. Optimum experimental designs. Oxford: Oxford University Press, 132 - 189.
- Bourquin L D, Titgemeyer E C, Fahey G C. Fermentation of various dietary fiber sources by human fecal bacteria[J]. Nutrition Research, 1996, 16(7): 1119 - 1131.
- Burcitt D P J Burkitt, Walker A R P, Painter N J. Dietary fiber and disease[J]. Journal of American Medical Association, 1974, 229: 1068 - 1077.
- Champ M, Guillon F. Structural and physical properties of dietary fiber and consequences of processing on human physiology[J]. Food Research International, 2000, 33: 233 - 245.
- Jiang Zhumao, Chen Xinmei, Miao Jing. Producing soluble dietary fiber from bean dregs[J]. Journal of the Chinese Cereals and oils Association, 2001, 16(3): 52 - 55. (in Chinese with English abstract)
- Jin Maoguo, Sun Wei. A study on the use of extrusion for raising the SDF content in soybean dregs[J]. Cereal & Feed Industry, 1996, (8): 35 - 38. (in Chinese with English abstract)
- Joglekar A M, May A T. Product excellence through design of experiments[J]. Cereal Foods Word, 1987, 32: 857 - 868.
- Lee S C, Prosky L, De Vries J W. Determination of total, soluble and insoluble dietary fiber in foods-enzymatic-gravimetric methods, MES-TRIS buffer collaborative study[J]. Journal of AOAC International, 1992, (75): 395 - 416.
- Liu Haofei, Cheng Jianjun, Wang Lei. Research on extraction conditions of soluble dietary fiber from soybean dreg by enzymatic method[J]. Science and Technology of Food Industry, 2008, 29(5): 202 - 207. (in Chinese with English abstract)
- Rodriguez R, Jimenez A, Fernandez-Bolanos J, et al. Dietary fiber from vegetable products as source of functional ingredients[J]. Trends in Food Science and Technology, 2006, 17: 3 - 15.
- Tharanathan R N, Mahadevamma S. Grain legumes—a boon to human nutrition[J]. Trends in Food and Science Technology, 2003, 14: 507 - 518.
- Tu Zongcai, Li Jinlin, Roger Ruan, et al. Process for increasing soluble dietary fiber content of soybean meals[J]. Transactions of the Chinese Society of Agricultural Engineering, 2007, 23(5): 246 - 250.
- Tu Zongcai, Lin Derong, Liu Chengmei, et al. Study on the technics of preparing soluble dietary fiber of high quality[J]. Science and Technology of Food Industry, 2008, 29(10): 149 - 152. (in Chinese with English abstract)
- Vasanthan Thava, Jiang Gaosong, Yeung Judy, et al. Dietary fiber profile of barley flour as affected by extrusion cooking[J]. Food Chemistry, 2002, 77: 35 - 40.
- Wang Jinghui, Cao Longkui, Ma Yuxia, et al. Study on producing high active dietary fiber soybean residue[J]. Journal of Jilin Agricultural Sciences, 2004, 29(3): 53 - 57. (in Chinese with English abstract)
- Xu Guangchao, Yao Huiyuan. The research of conditions for extraction of soybean soluble dietary fiber[J]. Journal of Henan University of Technology(Natural Science Edition), 2005, 26(1): 54 - 57. (in Chinese with English abstract)

- Zheng Dongmei, Xie Qinghui, Zhang Hongliang. The research on condition for pretreatment of dietary fiber of bean dregs[J]. *Food Science*, 2005, 26(9): 340 - 346. (in Chinese with English abstract)
- Zheng Yinghua, Ning Zhengxiang, Xu Keyong. Research on dissolution characteristics of soybean residue in alkali[J]. *Science and Technology of Food Industry*, 2008, 29(3): 117 - 119. (in Chinese with English abstract)

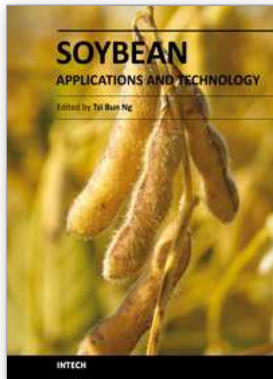

Soybean - Applications and Technology

Edited by Prof. Tzi-Bun Ng

ISBN 978-953-307-207-4

Hard cover, 402 pages

Publisher InTech

Published online 26, April, 2011

Published in print edition April, 2011

Soybean is an agricultural crop of tremendous economic importance. Soybean and food items derived from it form dietary components of numerous people, especially those living in the Orient. The health benefits of soybean have attracted the attention of nutritionists as well as common people.

How to reference

In order to correctly reference this scholarly work, feel free to copy and paste the following:

Yujie Chi (2011). Optimization of the Technology for Preparing Soluble Dietary Fiber from Extruded Soybean Residue, Soybean - Applications and Technology, Prof. Tzi-Bun Ng (Ed.), ISBN: 978-953-307-207-4, InTech, Available from: <http://www.intechopen.com/books/soybean-applications-and-technology/optimization-of-the-technology-for-preparing-soluble-dietary-fiber-from-extruded-soybean-residue>

INTECH

open science | open minds

InTech Europe

University Campus STeP Ri
Slavka Krautzeka 83/A
51000 Rijeka, Croatia
Phone: +385 (51) 770 447
Fax: +385 (51) 686 166
www.intechopen.com

InTech China

Unit 405, Office Block, Hotel Equatorial Shanghai
No.65, Yan An Road (West), Shanghai, 200040, China
中国上海市延安西路65号上海国际贵都大饭店办公楼405单元
Phone: +86-21-62489820
Fax: +86-21-62489821

© 2011 The Author(s). Licensee IntechOpen. This chapter is distributed under the terms of the [Creative Commons Attribution-NonCommercial-ShareAlike-3.0 License](#), which permits use, distribution and reproduction for non-commercial purposes, provided the original is properly cited and derivative works building on this content are distributed under the same license.

Benefits of Cover Crops in Soybean Plantation in Brazilian Cerrados

Pacheco, Leandro Pereira and Petter, Fabiano André
*Federal University of Piauí
Brazil*

1. Introduction

The demand for food overseas has been increasing due to the accelerated growth of population during the last decades, what has led to the incorporation of areas for agriculture by men and, above all, to the seek for increasing crop productivity. However, improper management of agricultural areas and climate changes have brought up a concern about the adoption of less harmful models of production, while talking about the worldwide environment.

The use of cover crops in areas in which soybean has been cultivated has become a widespread practice in several countries, mainly in tropical regions of the globe. In this chapter, we will focus on the use of cover crops in the Cerrado region of Brazil, since climate conditions of each region of the globe present different approaches to this subject. The high temperatures in these places promote an accelerated decomposition of soil organic matter, reducing fertility and increasing the emission of greenhouse gases into the atmosphere.

The use of cover crops in no-tillage soybean plantations, with no tillage and the presence of mulch on the soil surface, has brought to the Brazilian Cerrado areas a reduction in erosion, and it has increased the soil fertility (chemical, physical and biological attributes), the control of insects, diseases and weeds, and, also carbon sequestration from the atmosphere, due to the accumulation of soil organic matter (Bloom, 2002).

In Cerrado areas, in which there is a major occurrence of off-season with very high temperatures and low rainfall, from April to October, several techniques for the introduction of cover crops in soybean areas have already been tested. The presence of water stress after soybean harvest has hampered the establishment and growth of cover crops in succession, what makes necessary the use of species with fast growth and resistance to drought stress. Moreover, the decomposition rate of mulch on the soil surface is high, due to high temperature and the effect of soil microfauna on plant debris.

Nutrient cycling promoted by cover crops is another important factor for agriculture, by absorbing nutrients on subsurface layers and then releasing them on the surface layers through decomposition and mineralization of their residues (Torres et al., 2008). Some species still have the potential to accumulate nitrogen through biological fixation, which contributes about how to increase soil fertility.

Given this, the use of crop production systems, which aim at the introduction of cover crops with high capacity for biomass production, becomes essential. The no-tillage system, since it

does not turn over the soil, allows greater permanence of mulch on the soil surface, what contributes to its protection against the agents of erosion and to the accumulation of organic matter. The possibility of increasing soil organic matter promotes the carbon sequestration from the atmosphere and the reduction of greenhouse gases on the planet. This shows that agriculture has potential to contribute to food production and to a better standard of living of as for population, if conducted sustainably; using crop production systems that seek to reduce the impacts of human intervention on the environment.

2. Soil management systems in the Brazilian Cerrado

The occupation of the Cerrado took place more intensively in recent decades, emerging concern about the need of conservation practices to a sustainable agricultural system. The use of soil management systems, such as no-tillage (NT), has been done in an attempt to help increasing crop yield, reducing production costs and minimizing impacts of agriculture to rural and urban environment (Campos et al., 1995). According to Conab (2009), Brazil has grown more than 47 million hectares of grain crops in 2008/ 09, of which more than 25 million were under NT (FEBRAPDP, 2009). The conventional tillage (CT) recommends the use of implements that do the tilling of topsoil for planting annual crops, while the NT has been the only soil disturbance in the row (Figure 1) , presence of biomass on the soil surface and crop rotation (Kluthcouski et al., 2000). These practices help protecting against soil erosion and plant health problems, particularly diseases and weeds (Severino et al., 2006), in addition to that, there is an increase in the availability of nutrients and organic matter in the soil (Torres et al., 2005). Crop rotation also provides diversification of economic activity in agriculture and rural property.



Fig. 1. Soybeans grown in conventional tillage-CT (left) and no-tillage-NT on *Brachiaria ruziziensis* (right) in the region of Rio Verde, GO, Brazil. (Photos: Leandro Pereira Pacheco)

Velini & Pereira (2003) and Pacheco et al. (2009b) showed that the NT is even possible to keep problematic weeds under control, provided that they are employed in crop rotation programs combined with appropriate management and chemical control. Stone & Silveira (1999) have observed a better use of water from the soil by bean plants under NT, although there was a lower rate of surface soil compaction in the CT. Carneiro et al. (2009) showed that the NT provides the best conditions for growth of soil microbes, due to the increased supply of organic residues and moisture, and less variation of soil temperature. Torres et al.

(2005) and Boer et al. (2007) have noticed viability in the nutrients cycling by cover crops in NT, which may contribute to the rational use of fertilizers.

Studies have shown that the NT in the Cerrado presents some challenges. The producers of this region have faced some difficulties in production and in the maintenance of biomass on the surface, due to the high temperature and microbial activity in the decomposition, what makes the increase of soil organic matter difficult (Torres et al., 2005). Moreover, during the off-season between the months of April and September, characterized by a dry period with high temperatures, there are difficulties to the establishment of cover crops for formation of mulch (Pacheco et al. 2008; & Machado & Assis, 2010).

Improper use of the NT may compromise the natural resources and crop yield, due to physical, chemical and biological soil attribute quality reduction (Lamb et al., 2009). The use of cover crops sown in pre-harvest and after harvest of annual crops can provide improvements in these attributes, contributing to a more efficient use of water and nutrients, increasing crop productivity (Falleiro et al. 2003).

3. Cover crops in no-till system in the Cerrado

The cover crops used in the NT aim at protecting soil against erosion, and at contributing to the accumulation of organic matter and nutrients in the soil (Aita & Giacomini, 2006). In the Cerrado region, the use of cover crops is more widely seen in succession annual crops during the dry season, between the months of March and September, a dry period with high temperatures, what has hampered the formation of biomass (Boer et al., 2007). Pacheco et al. (2008) and Machado & Assis (2010) observed that the seeding of cover crops as early as possible, after soybean harvest, has resulted on a better performance of cover crops on biomass production, because of a better utilization of final rainfalls in April and May.

The high rate of decomposition of plant residues after management has also hampered the maintenance of biomass on soil surface (Crusciol et al. 2005; Boer et al., 2007, Torres et al., 2008). Some authors suggest that cover crops for this region must present a higher capacity for biomass production, and especially, a higher resistance to decomposition, which is related to the ratio of carbon and nitrogen (Crusciol et al., 2005, Torres et al., 2005) or the degree of residues recalcitrance (Giacomini et al., 2003).

Cover crops sown during the off-season, has the ability to perform the cycling of soil nutrients by absorbing them on subsurface layers and then releasing them on the surface layers through decomposition and mineralization of their residues (Figure 2). However, Braz et al. (2004) show that there is a necessity of synchronization between the release of nutrients by cover crops and the demand for crop in succession, which may be related to species and sowing of cover crops, as well as to the time of desiccation management. Carpin et al. (2008) point out that the flowering is the ideal time for the management of the plant cover, due to the higher accumulation of biomass and nutrients.

There are several species of cover crops recommended for the use in the Cerrado, especially some grasses and legumes. The grasses of *Brachiaria* spp. stand out by presenting perennial habit, high resistance to drought and high biomass production (Timossi et al., 2007; Machado & Assis, 2010). Pearl millet (*Pennisetum glaucum*) is notable for its rapid and early growth, drought tolerance and high biomass production (Boer et al., 2007). Legumes such as pigeonpea (*Cajanus cajan*) are highlighted in supplying nitrogen to plants, due to the presence of symbiosis with the nitrogen fixing bacteria (Aita & Giacomini, 2003). *C. cajan* is a perennial legume with high resistance to water stress (Amabile et al., 2000) and it has the potential to be used in association with grasses for the formation of straw in the SPD.

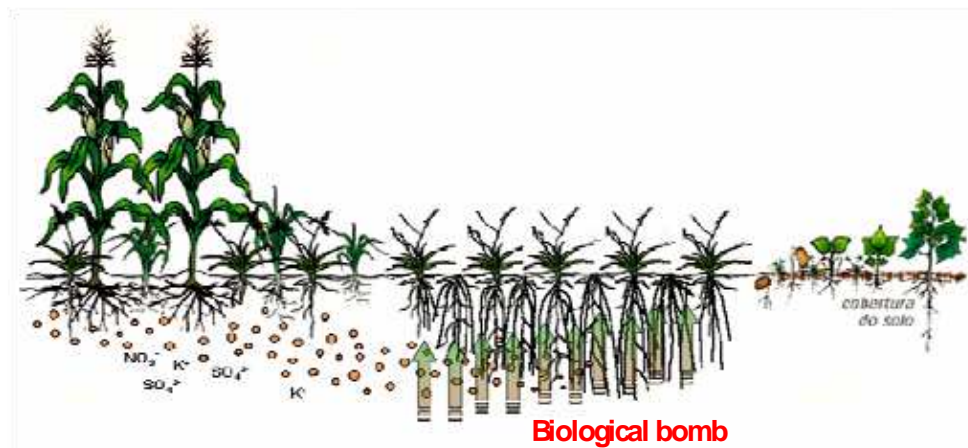

| | | | | | | | | | | | | |
|-----|------|------|------|------|------|-----|------|------|------|------|------|------|
| Oct | Nov. | Dec. | Jan. | Feb. | Mar. | ... | Jun. | Jul. | Aug. | Sep. | Oct. | Nov. |
|-----|------|------|------|------|------|-----|------|------|------|------|------|------|

Fig. 2. Nutrient cycling in corn and soybeans in rotation cropped in no-tillage system with the use of cover crops during the off-season in Brazilian Cerrado. (Picture: João Kluthcouski).

3.1 Pearl millet – *Pennisetum glaucum*

Pearl millet (*Pennisetum glaucum*) has been a cover crop widely used in off-season, because of its rapid growth, high biomass production and nutrient cycling in water deficit conditions. A Boer et al. (2007) study has pointed out in the Cerrado, the rapid growth of this kind, whose ADR 500 cultivar sown in April reached the level of 50% flowering to 51 days after emergence, dry matter production of 10,000 kg ha⁻¹ and with a capacity to accumulate in shoot 122 kg ha⁻¹, 17 kg ha⁻¹, 417 kg ha⁻¹, 76 kg ha⁻¹ and 40 kg ha⁻¹ of nitrogen (N), phosphorus (P), potassium (K), calcium (Ca) and magnesium (Mg), respectively.

Pacheco (2009) and Pacheco et al. (2009) observed that millet is a cover crop used in the Cerrado with greater capacity for biomass production (approximately 8,500 kg ha⁻¹), due to its rapid establishment and initial growth up to 60 days after sowing, after soybean harvest. Studies have shown that the time of millet sowing interferes in the ability of biomass production and nutrient accumulation. Torres et al. (2005), in the Cerrado region of Minas Gerais, observed that *P. glaucum* was able to accumulate over 150 kg ha⁻¹ and 50 kg ha⁻¹ of nitrogen when planted in October and March, respectively. These results are possible when considering the climate conditions are different in each planting period, mainly water availability for plant growth.

The high root growth of pearl millet can assist in unpacking the soil by the formation of preferential channels for water drainage and root growth of annual crops successors. According to Gonçalves et al. (2006), the use of millet to the decompression in cerrado soils is feasible, within thirty days getting high biomass and root length density in the compacted layers of soil to 1.60 Mg m⁻³. Bordin et al. (2008) observed that millet had higher root growth

to a depth of 60 cm, especially when we proceeded to chisel the soil surface. Pearl millet, because it is tolerant to the presence of aluminium (Al^{+3}) in the soil, can promote high root growth, although most of the Cerrado soils have levels considered toxic Al^{+3} on the layers below 20 cm in profile (Figure 3).



Fig. 3. Overview (A) and root growth (B) plant millet (*Pennisetum glaucum*) through the soil profile, and soybean crops in no-till millet straw (C) (Photos: Leandro Pereira Pacheco).

According to Torres et al. (2008), this species has a high resistance to the decomposition of their residues, with half-life of the biomass on the soil surface up to 131 days after its management, due to its high C/ N ratio, which can result on greater persistence of mulch on the soil surface. However, the physiological cycle of this species cultivated in off-season, in the Cerrado region, causes the decomposition and nutrient release from biomass to be premature if compared to the time of sowing of annual crops (Timossi et al. 2007 ; Pacheco et al. 2008; Pacheco, 2009a). This feature can interfere in the presence of biomass on the soil surface in the end of the off-season and in the utilization of nutrients by annual plants cropped in succession (Figure 4).

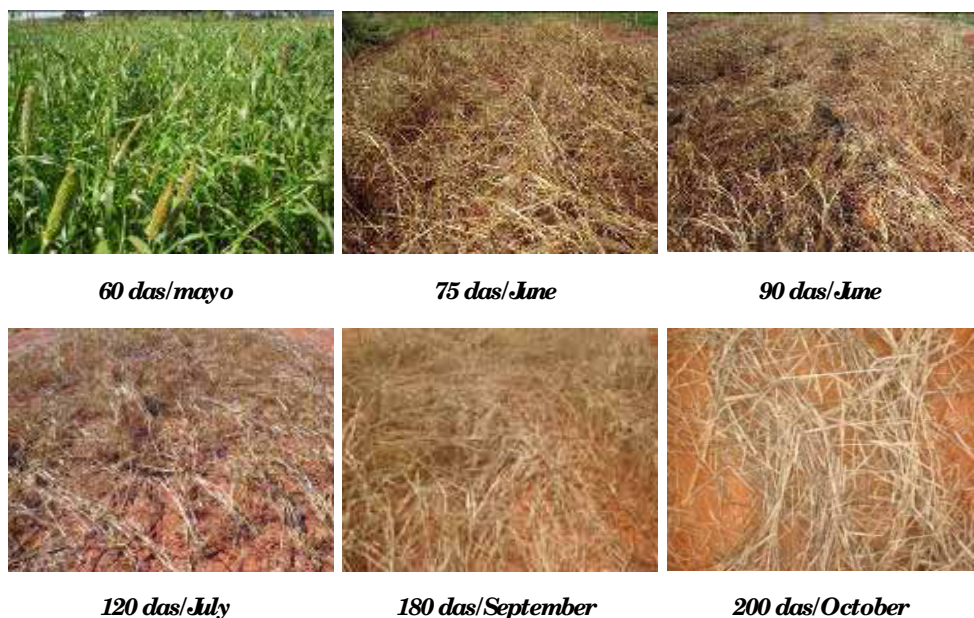

Fig. 4. Overview of the development of millet during the dry season, starting 60 days after sowing (DAS) by the end of the off-season, to 200 DAS in Goiânia, Brazil. (Photos: Leandro Pereira Pacheco).

3.2 *Brachiaria* – *Brachiaria* spp.

The use of cover crops with perennial habit, which are able to support drought stress and high light during winter and spring in Cerrado, such as the *Brachiaria* (*Brachiaria brizantha* and *B. ruziziensis*), can provide a significant accumulation of biomass and help delaying the beginning of its decomposition in relation to millet (Pacheco et al., 2008). According Timossi et al. (2007), the *brachiaria* species distinguished itself by a high adaptability to low soil fertility, an easy setting and a substantial biomass production during the off-season (Figure 5). These cover crops have great potential to the maintenance of biomass in the soil, because its high C/ N ratio, which slows decomposition and increases the possibility of use in regions with high temperatures.

In studies of Torres et al. (2005), *B. brizantha* sown in March and desiccated at 110 days was not significant in biomass production and accumulation of nitrogen, 2,100 kg ha⁻¹ and 41 kg ha⁻¹, respectively. The initial growth of this species is slow (Portes et al., 2000), however, the perennial habit enables its resume growth after the onset of rains in September, which can provide increase in biomass formation (Pacheco et al. 2008, Pacheco et al., 2009a).

Brachiaria species promotes the soil cover throughout the off-season and a significant increase in its biomass in the end of the dry season, with early spring/ summer rains that occur in the end of September through October in the Cerrado of Brazil. This is possible because of the perennial habit of this species and due to its high capacity of regrowing when the rainy season restarts, since there is a presence of vegetative buds in clumps and

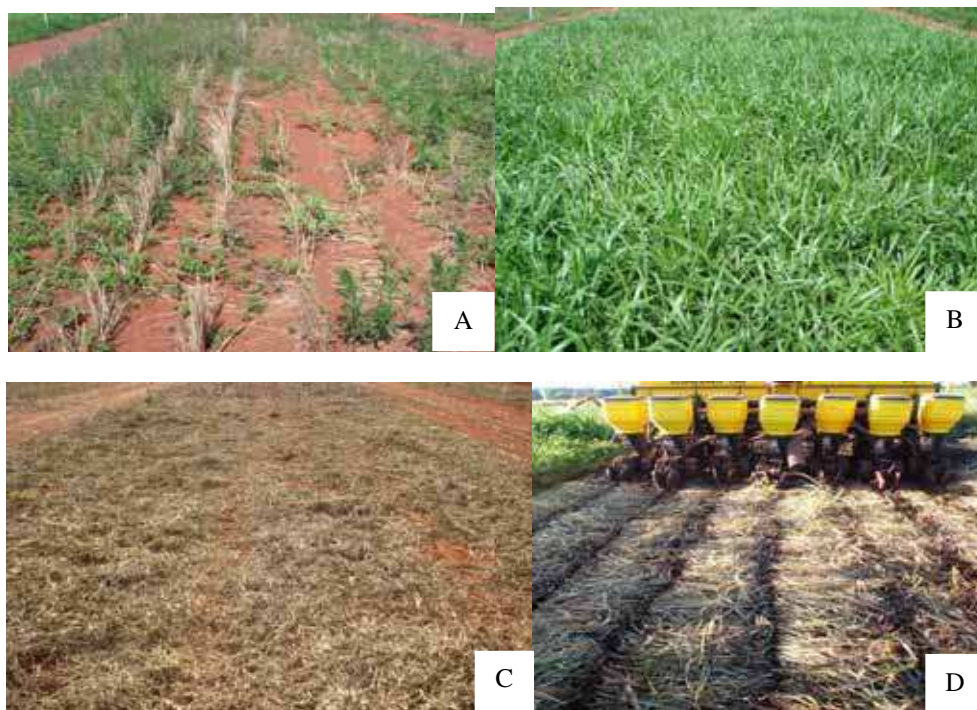

Fig. 5. Fallow area (A) and *Brachiaria ruziziensis* (B) the final of the off-season, in October, just before planting soybeans. *B. ruziziensis* desiccated (C) and soybean planting in no-tillage (D). (Photos: Leandro Pereira Pacheco).

stems of *Brachiaria* spp. (Portes et al., 2000). Moreover, when the first rain comes, plants have already developed root systems during the off-season, what favors the absorption of water and nutrients and the resumption of growth of aerial parts (Figure 6).

Comparing the performance of *B. decumbens* and *B. brizantha* to *P. Glaucum*, sown in March in the Cerrado region of São Paulo, Timossi et al. (2007) observed that the brachiaria was more efficient in biomass production (approximately 11,000 kg ha⁻¹). In the same study, *P. glaucum* has showed high biomass production at 110 days after sowing (10,500 kg ha⁻¹) in off-season, and when sowing the annual crop, there were only 3200 kg ha⁻¹ biomass for the NT. Pacheco et al. (2008) also observed high decomposition of the biomass of *P. glaucum* during the off-season in the Cerrado region of Goiás, noting that the earlier it was sowing in the off-season, the greater the loss of biomass by decomposition during the off-season was. A work in the Cerrado in Goiás showed that the *Brachiaria* has the potential of biomass production between 9,0 and 14,0 ton ha⁻¹ dry mass when planted after harvest of soybeans.

As for the cycling of nutrients, Menezes & Leandro (2004) observed that *B. ruziziensis* sown in December in the Cerrado had accumulated 240 kg ha⁻¹, 30 kg ha⁻¹, 406 kg ha⁻¹, 64 kg ha⁻¹ and 48 kg ha⁻¹, N, P, K, Ca and Mg, respectively, at 90 days after sowing. However, the growth of this species when sown in the off-season is different, because of the presence of long drought stress, what would result in lower values for biomass and nutrient recycling.

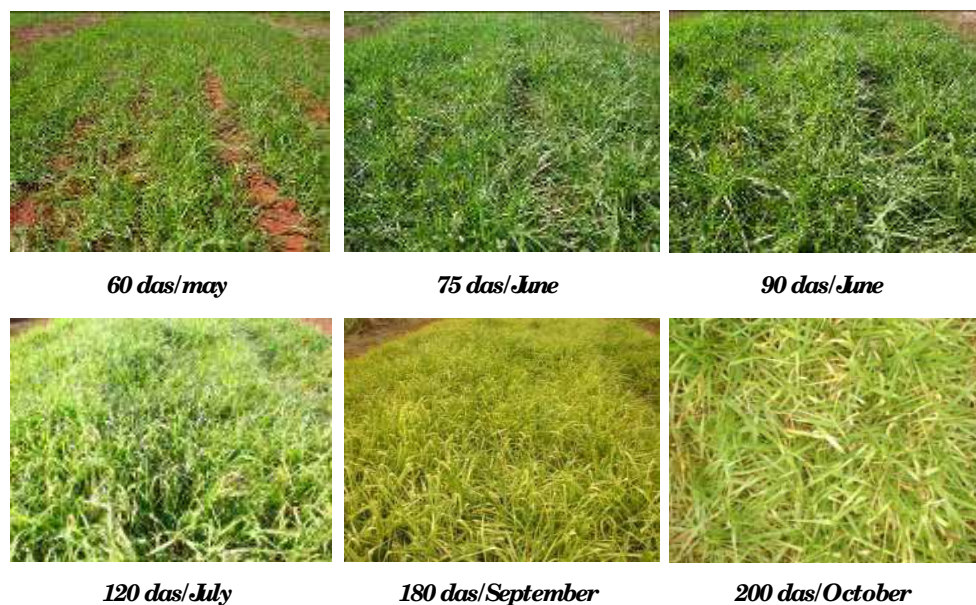

Fig. 6. Overview of the development of *Brachiaria brizantha* during the off-season, starting 60 days after sowing (DAS) by the end of the dry season, 200 DAS, in Goiânia, Brazil. (Photos: Leandro Pereira Pacheco).

Studies of Pacheco et al. (2009a) observed that *Brachiaria* (*B. brizantha* and *B. ruziziensis*) when sown after soybean harvest (March), get to accumulate until the beginning of the next harvest (October) in Cerrado, about 150 kg ha⁻¹, 13 kg ha⁻¹, 118 kg ha⁻¹, 78 kg ha⁻¹ and 40 kg ha⁻¹, N, P, K, Ca and Mg, respectively. After desiccation management for soybean planting, the K is the nutrient with the highest release rate in the soil, and 50% of the total accumulated time (half-life) is released in the soil up to 15 days after this operation. The other nutrients have slower release, showing a longer half life between 40 and 60 days after desiccation.

According to results of Reis et al. (2001), the high values of N accumulated by the biomass of *P. glaucum*, *B. brizantha* and *B. ruziziensis* can also be influenced by their abilities to join with N-fixing bacteria by symbiosis, with predominance of species of *Azospirillum* and *Herbaspirillum*. As said by these authors, this process may contribute more than 40% and 20% of N accumulated in biomass of *P. glaucum* and *Brachiaria* spp., respectively.

B. brizantha presents difficulties as for desiccation management for soybean planting due to the high tolerance to glyphosate herbicide. Paraquat, due to its low translocation by phloem and xylem pathways, also fails in providing satisfactory control of ragweed. Chemical control using herbicides in this species may not be enough for total plant control, what provides conditions for its resumption of growth and regrowth during the development of soybean sown in succession (Figure 7). The herbicide glyphosate is a systemic mechanism, EPSP inhibitor (5-enolpyruvylshikimate 3-phosphate synthase). However, there are cases of plant resistance to this herbicide by reducing the mechanism of translocation via xylem and phloem, and also changes to the site of herbicide action in plants (Powles, 2008). Constantin et al. (2008) have reported difficulty in controlling *Brachiaria* species by glyphosate.



Fig. 7. *Brachiaria brizantha* regrowth after desiccation management with the use of glyphosate for soybean planting. (Photos: Leandro Pereira Pacheco).

These results demonstrate that *B. brizantha* needs to be managed so that plants can absorb and translocate the herbicide desiccant to the lateral buds in clumps, to prevent their sprout and interference in the growth of annual crops in succession. Increasing the dose of the herbicide may not be ideal, as described in works of Constantin et al. (2008), which show that high doses of glyphosate desiccation brachiarias management can interfere with growth and grain productivity of soybeans and corn. Moreover, the species *B. ruziziensis* single or intercropped with *C. cajan* emerges as a good choice for high production of biomass and ease of management for the SPD in Cerrado, contributing to reduce the soil erosion caused by rains that occur mainly in the early growth stages of annual crops.

Another obstacle in the use of *Brachiaria brizantha* is in plantability of soybeans on its biomass. It seems that this plant has a high coverage rate of formation of clumps, what makes seed deposition difficult when soybean planter is sowing, leaving it on the soil surface (Figure 8). It is recommended, while sowing *B. brizantha* during the off-season, to use a higher density of plants to prevent the formation of clumps and to facilitate soybean planting as for the next harvest. Furthermore, the brachiaria can induce initial soybean seedlings etiolating in no-tillage system, because of excessive shading caused by the mulch in the row. In order to reduce this problem, it is recommended not to allow excessive growth of *Brachiaria* after the resumption of rains, carrying out its desiccation at the right time. Another option would be the use of implements to grind the mulch after desiccation, resulting in a homogeneous distribution of biomass on the soil, what would make the process of sowing easier. However, one needs to carry out this operation in required intervals since it is necessary to have the herbicide applied in desiccation translocated via phloem to the growing parts of *B. brizantha*, preventing its regrowth during the growth of soybean sown in succession.

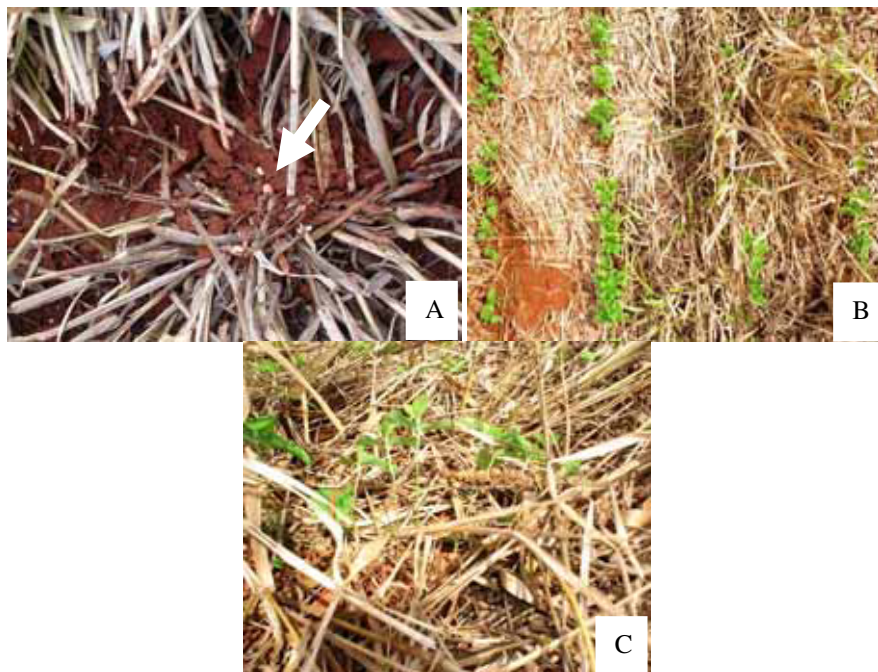

Fig. 8. Failures in the soybean seed deposition at sowing by the planter (A), reduction of stand (B) and soybean seedlings etiolation (C) under no-tillage on mulch of *Brachiaria brizantha*. (Photos: Leandro Pereira Pacheco).

3.3 Pigeon pea – *Cajanus cajan*

The *Cajanus cajan* is a perennial legume with the potential to be used as cover crop in the NT, since it presents a high resistance to drought and it performs the biological nitrogen fixation (Henriksen et al., 2002). Torres et al. (2005) showed that *C. cajan* reached 62 kg ha⁻¹ N in its biomass at 110 days after planting in off-season. Menezes & Leandro (2004) also observed that excessive use of grasses in the production systems results in competition for N by plants during the process of organic matter mineralization.

Studies have shown increases in opportunities in biomass, rate of ground cover of *C. cajan*, due to its resumption in growth after the early spring-summer rains (Bordin et al., 2008). This feature is important to cover crops in Cerrado, since it reduces the mineralization process and, above all, allows greater biomass and nutrient accumulation during the off-season for the NT in annual crops in succession.

Legume species of *Brachiaria* spp. with perennial legumes such as *C. cajan* (Figure 9) can provide high biomass production (Amabile et al., 2000) and nitrogen biologically fixated in the soil accumulation (Henriksen et al., 2002). Gama-Rodrigues et al. (2007) showed that the introduction of leguminous cover crops increased the quality of its residues, due to higher supply of N, P and Ca to the soil.

By consorting legumes and grasses, a C/ N intermediate ratio biomass, the same as single crop species can be obtained (Figure 9). This characteristic increases the nutrients release to the soil after the desiccation of cover crops for planting annual crops, what would allow a

reduction in the need of using fertilizer. Espindola et al. (2006) highlighted the potential of the herbaceous perennials in the release of nutrients for crops successor, due to the chemical composition of the residues. In this study, the nutrient releases are correlated to the levels of cellulose ($r = -0.92$), hemicellulose ($r = -0.95$) and C/ N ratio ($r = -0.99$). In addition, Bordin et al. (2008) pointed to the pigeon pea as a cover crop that promises to be satisfactory at decompressing soil layers, considering its aggressive root system.



Fig. 9. *C. cajan* and *B. ruziziensis* in consortium during the off-season in Brazilian Cerrado (A) and *C. cajan* resistance to the application of glyphosate in desiccation management for soybean seeding (B) (Photos: Leandro Pereira Pacheco).

Some care must be considered while talking about the use of pigeon pea. As its initial growth is slow and it is sensible to photoperiod, we recommend its use on those occasions when you can sow it earlier, so the species can develop the first 60 days after sowing in soil moisture conditions. Important information is the resistance of this species to the herbicide glyphosate (Figure 9). Given this, to its desiccate management for soybean planting it is recommended the use of herbicides with other action mechanisms, such as paraquat and diquat.

3.4 Crotalarias – *Crotalaria juncea*, *C. spectabilis* and *C. ochroleuca*

The crotalarias are cover crops widely used in the Cerrado, because it is a legume with rapid growth, high biomass production, and it promotes the nitrogen biological fixation in the soil. The *Crotalaria* can be grown alone or in consortium with other cover crops, such as the brachiaria both in pre-harvest and after the soybean harvest. Several research studies have shown that crotalaria can produce between 5,0 to 6,0 ton ha⁻¹ when sown in the fallow biomass of the Cerrado (Figure 10).

It's a species of short days, photoperiod sensitive, capable of producing more biomass when planted in October/ November in the Cerrado of Brazil. Some research studies indicate that there is a reduction of biomass production by this species when sown in the end of the rainy season (March), due to the reduction of photoperiod and less water availability for plant growth. Studies of Amabile et al. (2000) observed a reduction of more than 50% of biomass production when comparing crotalaria sowing in the beginning and in the end of the rainy season, November and March, respectively.



Fig. 10. *Crotalaria juncea* in flowering fenological stage (Photos: Leandro Pereira Pacheco).

Crotalaria presents high capacity to biological nitrogen fixation through associations with bacteria. Researches show that the increase of nitrogen in the soil by this pathway can be up to 165 kg ha^{-1} . Although soybean also performs the biological fixation of nitrogen, the increase of this element to soil favors the accumulation of organic matter, which favors the fertility of the Cerrado soils. In agricultural areas newly incorporated into the soybean, it becomes necessary to use the seeds with inoculant bases nitrogen fixing bacteria.

The continuous use of *crotalaria* may provide some problems regarding the control of insects and diseases. Some nematodes that cause damage in soybean have shown ability to colonize and multiply in the roots of *crotalaria*. Given this, it's recommended to use this cover crop in rotation with other species in order to promote the breaking of the microorganism cycle and pest population increasing.

Some studies indicate the feasibility of consortium with *crotalaria* and *brachiarias* during the off-season in Brazilian Cerrado. This measure aims at combining the high capacity for biomass production of *Brachiaria* and the possibility of increased biological nitrogen fixation promoted by *crotalaria*. However, further studies are needed to be able to define the best operating consortium, as for the ideal density of plants of each species and form of planting.

4. Soybean crop oversowing used as a technique to biomass formation in no-tillage

The introduction of cover crops in the Cerrado has presented several difficulties. The restricted water availability after harvesting the annual crops may, in some regions, markedly impair the growth of cover crops sown in the period. Given this, systems that can optimize the use of late season rains can contribute to biomass production during the off-season. The introduction of cover crops at an earlier time in soybean crops, immediately before harvest, through consortium, may be a key factor for the success of the system.

Legume cover crops in early stages of soybean development have originated serious problems. The researches results observed that the photosynthetic mechanism for soybean C_3 carbon fixation accumulates less biomass if compared to cover crops used in the Cerrado, like the millet and the *brachiaria*. These characteristics provide limited competitive capacity of the legume in relation to cover crops, what is a major factor in the failure of soybean in

consortium (Portes et al., 2000, Pacheco et al., 2008). Moreover, the process of grain harvest is significantly affected by low cutting height of the harvester machine platform, causing considerable loss of harvest efficiency (Figure 11).

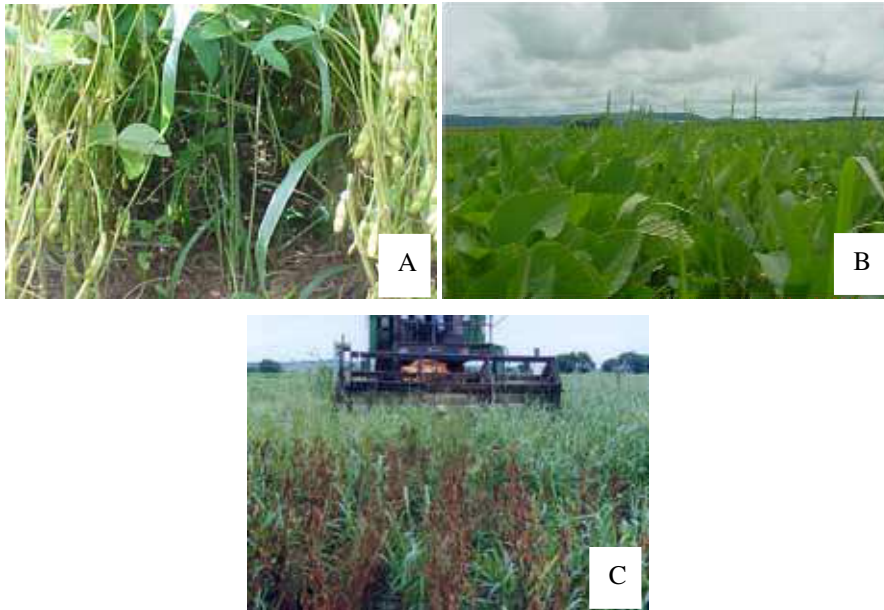

Fig. 11. Problems in the consortium between soybean and brachiaria: competition between species, causing yield losses in soybean (A and B), difficulties in the process of grain harvesting because the excess biomass (C). (Photos: Embrapa Arroz e Feijão).

The cover crops oversowing, when physiological maturity of soybean already exists (beginning of defoliation: R7 stage), seems to be a promising alternative consortium, providing greater flexibility in the operational schedule of the culture, especially in the process of grain harvest (Figure 10). The success of the system depends mainly on climatic conditions since the eve of sowing until 10 days after emergence of cover crops, seed germination and plant growth on soil surface.

The work of Lara-Cabezas (2004), with pelleted seeds of millet, IAPAR (2005), Trecenti (2005) and Pacheco et al. (2008), focused on eight cover crops, pointed oversowing as a viable alternative to address the maintenance of trash in the SPD. However, to fulfill the oversowing, it becomes necessary to use species that show good adaptation to consortium cropping, without negative effect in the annual crop (Trecenti, 2005); tolerant to drought, because its implementation will coincide with the start of the dry season (Lara-Cabezas, 2004); produce high amounts of biomass for soil cover (Gazatta et al. 2005; Perin et al., 2004) and have the ability to forage for feeding animal in winter. In addition to that, there are several questions about the conditions that optimize the use of this practice, as the amount of seed and the behavior of ideal cover crop oversowing at different times, what is directly connected to the implantation of soybeans, the delay will result in greater climate risk for the development of cultivated species for formation of mulch.

Pacheco et al. (2008) showed that the occurrence of dry spells after extensive cover crops oversowing on soybean resulted in reduction of emergence of plants. This is because, when the process of seed germination starts there is the rupture of seed coat and the radicle protrusion, which, in turn, is very sensitive to desiccation. Considering that seeds in oversowing are on the surface of the soil, a prolonged period of drought may promote the death of the seedlings germinated recently, causing significant stand reduction, what can compromise the technique success. To reduce these effects, the amount of cover crops seeds used on soybean oversowing needs to be larger in order to compensate for possible losses of seed germination and plant establishment.

During cover crops oversowing, if seeds have the possibility of germinating due to climatic conditions and seedlings get established, there have been significant gains in the ability of plants to accumulate biomass in coverage for the NT. In this way of sowing, plants have increased utilization of final harvest time rains to develop, increasing the growth of shoots and roots, allowing a larger resistance to water stress during the off-season and increases in biomass accumulated until the next harvest.

The distribution of seeds of cover crops oversowing on soybean can be performed using an air-plane or implements pulled by tractor. The advantage in aerial application is the agility and the absence of kneading in culture. However, the application cost is higher.

Thus, the search for strategies for the implementation of cover crops in the off-season may represent important alternative to the efficient mulch production to the NT in the Cerrado, without interference on the annual crop. This certainly is encouraging its adoption on a

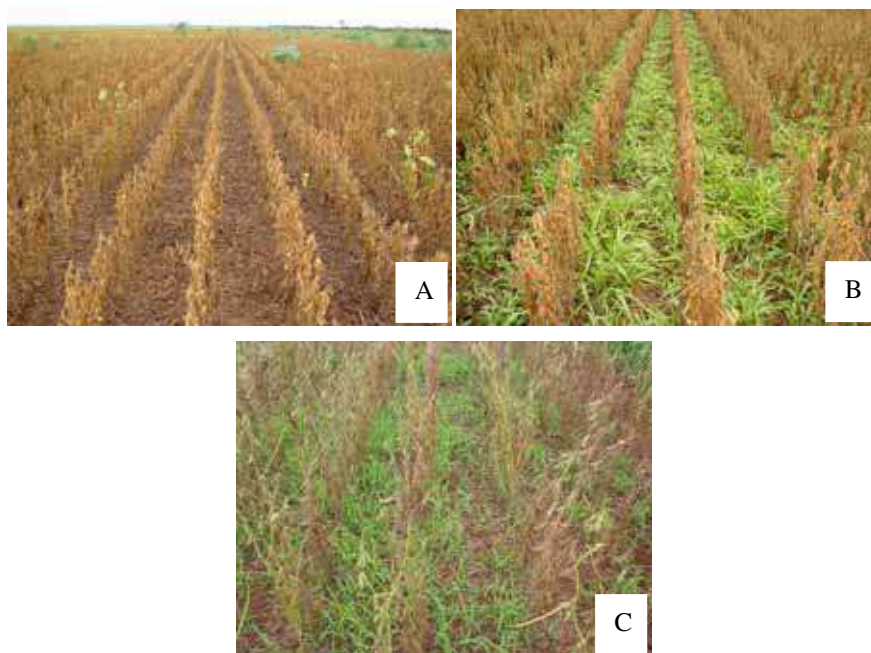

Fig. 12. Comparison of soybean single (A) and the use of *B. ruziziensis* (B) and *P. glaucum* (C) on soybean oversowing at realized in physiological maturity Stadium-R7-onset defoliation. (Photos: Leandro Pereira Pacheco).

larger scale by farmers, especially those who grow genetically modified soybeans, for which the use of post-emergence glyphosate culture eliminates the possibility of simultaneous consortium with cover crops. In this case, the main option for consortium of soybean and cover crops is oversowing.

5. Improvements in soil quality promoted by cover crops

Cover crops have important functions in agricultural systems, not only by being inserted in management plans as an example of no-tillage, acting as one of its basic premises, which is the constant maintenance of these plants in cultivation areas, but also by providing benefits to the soil.

The effects of cover crops are not restricted to their protective effect on the soil surface, preventing the direct impact of rain drops on the soil, promoting the breakdown of particles and consequently reducing erosion and water evaporation from the soil. These plants have a direct influence on the physical, chemical and biological soil attributes, as well as helping to control weeds through the suppressive effect it has on them and, in many cases, due to their allelopathic effect through the release of chemicals compounds in the soil.

The importance exerted by the cover crops was highlighted as the effects of a predatory and extractive agriculture have intensified with regard to soil conservation. The intense anthropogenic activities on agricultural land without proper planning of land use has led to a process of degradation of its productive capacity (Kluthcouski & Stone, 2003), generating losses on the more fertile layers of the soil, those coming to 200 Mg ha⁻¹ year⁻¹ (Franco & Campello, 2005). In tropical and subtropical regions, the effect of inadequate soil management gets worse mainly by the loss of organic matter (OM), since the mineralization rate of OM reaches high levels, due to high temperature and microbial activity in the decomposition of residues, reducing the amount of these compounds in the soil (Torres et al., 2005). The OM soils in these regions account for approximately 80% of cation exchange capacity (CEC).

The maintenance of cover crops contributes to an increase of vegetable residues to the soil which will become OM stable, contributing to the maintenance of high levels of fertility and crop productivity.

5.1 Soil physical attributes

The soil physical attributes are significantly influenced by management type, and the structures of the initial aggregate feature that suffers most of the change, what eventually can influence on a number of other parameters. According to Kluthcouski & Stone (2003), the physical characteristics of soil are interdependent, and as said by Vieira (1985), the modification of an attribute leads to the modification of all the others.

Therefore, the presence of cover crops itself, does not necessarily affect soil characteristics positively, it is necessary to give emphasis to the type of management that will be adopted for this system. Several parameters have been used to assess the sustainability of production systems, including assessing the state of soil aggregation, through the stability of aggregates (Moreira et al., 2009) and S index (Dexter, 2004), making possible the comparison of different management practices and soil physical characteristics. According to Dexter (2004), values of S considered as indicators of good quality structures are above 0,035.

The incorporation of crop residues to plant hedges using implements that stir the soil tends to lose its original structure, fractionating aggregates into smaller units, generating a

reduction in macroporosity, microporosity and an increase in density (Carpenedo & mielniczuk, 1990). In conventional tillage, where soil disturbance is the basis of the practice, the influence of cover crops is not manifested to such an extent and vary from species to species, mainly due to morphological and physiological characteristics of the root system (Table 1).

| Trat. | BS (kg ha ⁻¹) | Dept. (cm) | PT | MI | MA | Ds | S index | DMP | >2mm |
|-------|------------------------------|---------------|--------------------------------|--------------------------------|--------------------------------|--------------------|---------|-----|------|
| | | | m ³ m ⁻³ | m ³ m ⁻³ | m ³ m ⁻³ | Mg m ⁻³ | | | mm |
| PO | 1.942 | 0-10 | 0,462 | 0,358 | 0,101 | 1,44 | 0,023 | 1,7 | 25,2 |
| | | 10-20 | 0,449 | 0,401 | 0,048 | 1,47 | 0,020 | 2,2 | 36,6 |
| | | 20-30 | 0,551 | 0,396 | 0,055 | 1,47 | 0,020 | 1,8 | 28,5 |
| CR | 4.430 | 0-10 | 0,465 | 0,405 | 0,060 | 1,43 | 0,022 | 1,7 | 27,9 |
| | | 10-20 | 0,444 | 0,395 | 0,049 | 1,48 | 0,018 | 2,1 | 33,9 |
| | | 20-30 | 0,448 | 0,392 | 0,056 | 1,47 | 0,018 | 2,0 | 32,5 |
| GD | 3.528 | 0-10 | 0,473 | 0,405 | 0,067 | 1,41 | 0,023 | 1,5 | 21,3 |
| | | 10-20 | 0,461 | 0,405 | 0,056 | 1,45 | 0,022 | 2,0 | 32,4 |
| | | 20-30 | 0,454 | 0,401 | 0,053 | 1,46 | 0,021 | 1,9 | 30,9 |
| MU | 2.993 | 0-10 | 0,481 | 0,348 | 0,133 | 1,41 | 0,280 | 2,0 | 33,2 |
| | | 10-20 | 0,471 | 0,383 | 0,088 | 1,34 | 0,022 | 2,3 | 38,3 |
| | | 20-30 | 0,461 | 0,362 | 0,099 | 1,44 | 0,018 | 2,1 | 33,8 |
| SO | 13.250 | 0-10 | 0,508 | 0,389 | 0,120 | 1,31 | 0,026 | 2,4 | 41,8 |
| | | 10-20 | 0,447 | 0,394 | 0,053 | 1,48 | 0,019 | 2,6 | 44,7 |
| | | 20-30 | 0,443 | 0,371 | 0,072 | 1,49 | 0,019 | 2,1 | 37,4 |

Table 1. Dry biomass (BS) cover crops (PO - fallow, CR - crotalaria, GD - pigeon pea, MU - velvet and SO - sorghum), total porosity (PT), (MI), macroporosity (MA), bulk density (Ds), the S index, mean particle diameter (DMP) and aggregates larger than 2mm (> 2mm) of a soil at different depths evaluated. From: Moreira et al. (2009).

The NT allows the cover crops to be incorporated into the system without soil disturbance, not affecting the soil structure. In the Cerrado, this fact has great importance due to rapid decomposition of crop residues as a function of temperature and humidity. The rate of decomposition can be reduced not only by the practice of non-incorporation of crop residues to the soil, but also, by the implementation of species with high C/ N.

However, with no soil disturbance it is common in the NT the formation of compacted layers, mainly caused by traffic of agricultural machines in the crop areas. Soil compaction has been reported by many researches (Andrews et al., 1998, Bell et al. 1994; Richart et al., 2005) as a soil physical factor that limit crop productivity. Therefore, it is convenient to use plant species that have aggressive root system and high biomass production. The use of different management and species of cover crops can reduce soil compaction as shown in Table 2. According to Amado et al. (2001), different cover crops affect differently the stability of aggregates.

| Trat | Soil layers (m) | | | | | | | |
|------|-----------------|------|-------------|------|-------------|------|-------------|------|
| | 0,0- 0,10 | | 0,10 - 0,20 | | 0,20 - 0,30 | | 0,30 - 0,40 | |
| | 2004 | 2007 | 2004 | 2007 | 2004 | 2007 | 2004 | 2007 |
| T1 | 3,16 | 1,29 | 5,97 | 3,96 | 4,12 | 4,23 | 5,14 | 4,10 |
| T2 | 3,54 | 1,45 | 5,72 | 4,70 | 4,25 | 4,42 | 3,66 | 4,32 |
| T3 | 3,25 | 1,22 | 5,63 | 3,67 | 4,17 | 4,04 | 3,77 | 4,72 |
| T4 | 3,33 | 1,83 | 5,71 | 4,21 | 4,26 | 4,14 | 3,45 | 4,02 |
| T5 | 3,62 | 1,24 | 5,96 | 4,38 | 4,05 | 4,35 | 3,71 | 4,41 |
| T6 | 3,82 | 1,58 | 5,93 | 4,40 | 4,39 | 4,36 | 4,25 | 3,98 |
| T7 | 3,46 | 1,59 | 5,06 | 4,86 | 4,37 | 4,41 | 4,49 | 5,01 |
| T8 | 1,99 | 1,99 | 2,76 | 2,76 | 3,21 | 3,21 | 3,74 | 3,74 |

Table 2. Soil resistance to penetration (MPa) of a soil submitted to seven different treatments, evaluated at two different times of conduction of the experiment. T1 – Limpograss; T2 – Tifton; T3 – Pensacola; T4 – Limpograss + Pinto peanut ; T5 – Tifton + Pinto peanut; T6 – Pensacola + Pinto peanut; T7 – Pensacola + Fallow treatment (*Brachiaria humidicula* + *Brachiaria brizanta*) + Pinto peanut; T8 – soil without cover crops. From: Gonçalves et al. (2007).

The continuous use of cover crops in farming systems that adopt the NT as management, tends to provide better physical qualities to soil, however, the mulch must be sufficient to maintain soil structure and prevent the formation of compacted layer, otherwise it may lead to increased soil bulk density, reducing the porosity (Kluthcouski & Stone, 2003), resulting in lower moisture retention and increased soil resistance to penetration. Several studies (Derpsch et al. 1991; Kluthcouski, 1998; Vieira, 1985) show higher values of density and lower values of macroporosity in NT compared to conventional system.

The effect of cover crops may be more evident over the years when managed under NT, with increasing amounts of soil organic matter, which leads to increased aggregation of soil particles, reduction in soil density and increase of biological pores.

5.2 Soil chemical attributes

Cover crops in addition to soil physical attributes also influence in their chemical attributes, mainly acting as "biological pumps", nutrients cycling in the soil-plant system. The nutrients are absorbed through the root system of plants and brought to the surface after decomposition of plant residues. The system has a predominantly nutrient accumulation in the 0-5 cm layer, which can be confirmed by Sa (1993), that occurred after 4 and 16 years of implementing the NT, increased levels of P in the 0 -2.5 cm, from 29 mg dm⁻³ to 129 mg dm⁻³, respectively. The effectiveness of cover crops on nutrient cycling is related to their morphological and physiological characteristics, particularly in relation to root growth and biomass production of shoots. According to Favero et al. (2000), nutrient accumulation is proportional to the amount of biomass produced and the efficiency of absorption of nutrients, which vary among species. Table 3 shows the amounts of nutrients absorbed by different species.

The effect of nutrient cycling is not only in the fact of increasing their availability, but also in the form these are made available. In the decomposition of plant residues, many nutrient are released in organic form, especially nitrogen (N). Another element that is benefited from the mulch and plant cover is P, since in this system there is moisture retention, reduction in contact with ion surfaces with clay charged surfaces, reducing their adsorption (fixation),

| Cover crops | Days after sowing | | | | | |
|-----------------------------------|-------------------|-------|-------|-------|-------|-------|
| | 60 | 75 | 90 | 120 | 180 | 200 |
| Nitrogen (kg ha ⁻¹) | | | | | | |
| <i>B. ruziziensis</i> | 58,7 | 140,8 | 130,2 | 113,9 | 96,3 | 155,9 |
| <i>B. brizantha</i> | 52,0 | 123,0 | 144,7 | 171,7 | 137,5 | 142,8 |
| <i>P.glaucum</i> | 148,8 | 96,2 | 61,5 | 60,8 | 44,5 | 38,1 |
| Fallow | 16,3 | 37,9 | 35,0 | 34,0 | 17,9 | 35,8 |
| Phosphorus (kg ha ⁻¹) | | | | | | |
| <i>B. ruziziensis</i> | 8,6 | 11,0 | 9,7 | 6,4 | 9,7 | 12,4 |
| <i>B. brizantha</i> | 8,0 | 12,8 | 10,5 | 14,7 | 8,1 | 13,5 |
| <i>P.glaucum</i> | 35,1 | 27,1 | 13,5 | 13,3 | 8,1 | 6,9 |
| Fallow | 2,7 | 3,3 | 3,2 | 4,3 | 1,7 | 4,1 |
| Potassium(kg ha ⁻¹) | | | | | | |
| <i>B. ruziziensis</i> | 40,3 | 78,8 | 91,1 | 84,6 | 60,4 | 118,9 |
| <i>B. brizantha</i> | 25,2 | 88,8 | 87,7 | 143,8 | 90,6 | 126,6 |
| <i>P.glaucum</i> | 135,1 | 80,6 | 59,6 | 55,5 | 32,5 | 23,4 |
| Fallow | 5,1 | 24,5 | 27,7 | 29,7 | 20,6 | 26,8 |
| Calcium (kg ha ⁻¹) | | | | | | |
| <i>B. ruziziensis</i> | 16,1 | 31,9 | 53,5 | 39,7 | 46,9 | 63,37 |
| <i>B. brizantha</i> | 8,2 | 27,9 | 41,1 | 39,6 | 52,1 | 91,29 |
| <i>P.glaucum</i> | 55,4 | 31,1 | 27,2 | 22,7 | 21,0 | 17,67 |
| Fallow | 5,3 | 10,9 | 30,21 | 26,3 | 20,2 | 26,11 |
| Magnesium (kg ha ⁻¹) | | | | | | |
| <i>B. ruziziensis</i> | 6,3 | 28,2 | 34,9 | 33,1 | 26,5 | 35,17 |
| <i>B. brizantha</i> | 6,2 | 30,9 | 38,8 | 61,8 | 54,3 | 58,78 |
| <i>P.glaucum</i> | 47,8 | 27,7 | 18,6 | 16,8 | 15,7 | 13,45 |
| Fallow | 1,8 | 6,5 | 7,5 | 12,1 | 7,6 | 14,51 |

Table 3. Nutrient accumulation in biomass cover crops sowed after soybean harvest, measured at six times during the off season. From: Pacheco et al. (2009).

and an increase on the availability of P- inorganic layer (cycling) and P-organic in deeper layers (root exudation). The K is the nutrient with the largest and fastest return to the soil with the decomposition of cover crops (Figure 12). This is because it is not part of any organic compound in plants. The K cycling through the cover crop is very important, since the loss by leaching in soils of the cerrado is intense.

The accumulation of biomass by cover crops contributes to increase in OM content; however, this is dependent on management to be adopted in the culture system and the C/ N ratio of plant residues. The incorporation of crop residues results in loss of C, which is already naturally high in Cerrado conditions due to high temperatures (Torres et al., 2005). The increase in content OM is very important in Cerrado conditions due to the low cation exchange capacity (CEC) and anion (AEC) originated from clay and sandy soils of low activity, and represents about 80% of CEC of these soils. The possible increase of CEC and AEC with the use of cover crops resulted in greater availability of nutrients. Testa et al. (1992) observed proportional increases in the levels of Ca, Mg and K as a result of a higher CEC. Heinrichs et al. (2005) observed an increase in levels of P and K after the implantation of cover crops in consortium. Yet, Santos & Smith (1996), after four years of NT in soil

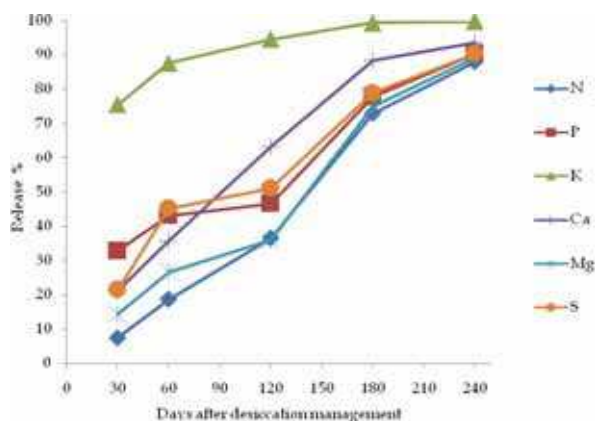

Fig. 12. Percentage of nutrients released from the millet residues, until 240 days after management. From: Adapted from Boer et al. (2007).

organic matter with more than 40 g kg⁻¹ found no effect on soil chemical attributes. Given this, it is evident the greater effect of cover crops in soils with low OM contents.

Effect of cover crops on the NT is also observed in the reduction of acidity and toxic aluminum (Franchini et al. 1999; Salet, 1998; Sumner & Pavan, 2000). According to Miyazawa et al. (2000), the ability of cover crops residues in reducing soil acidity is related to the concentration of basic cations and soluble organic carbon. Another interesting aspect of plant residues is the fact that due to its amphoteric characteristic a pH reduction occurs in alkaline soils and a pH increase in acidic soils.

It is noteworthy that the cover crops on the NT managed do not recover the chemical fertility of the soil, especially in the Cerrado, where there are naturally poor soils (Kluthcouski & Stone, 2003), and for the successful establishment of the NT it is necessary to correct the initial attributes of soil fertility. The increase of the productive potential of these soils is mainly the effect of CEC increase caused by an increase in soil organic matter.

5.3 Soil biological attributes

Keeping mulch on the soil surface through cover crops contribute to the physical and chemical characteristics of soil improvements, it also stimulates the activity of soil microorganisms, serving as an energy source, thereby altering the activity of micro and mesofauna and mainly by increasing microbial diversity. Microorganisms' activities in Cerrado conditions that are already high, become even greater by the presence of cover crops. This generates intense ground motion, contributing to the increase of biological pores, which store different organic compounds that will be decomposed and mineralized, contributing to the improvement of chemical characteristics of the soil.

The effect of cover crops and different management systems can be evidenced by the activity of microorganisms by analysis of soil quality indicators. According to De-Polli & Pimentel (2005), it is essential to dispose of sustainability indicators of soil, indicating the degree of conservation of a particular management system. Among the various biological attributes that are influenced by human activity through changes in management systems, stands out C and N microbial biomass, respiration rate (CO₂ emission or O₂ consumption),

microbial quotient (qMIC) (De-Polli & Pimentel, 2005, Karlen et al., 1997) and metabolic quotient (qCO₂), considered by Anderson & Domsch (1993) as a biological indicator of human activity more precisely on the soil microbial activity, which is the ratio of respiration basal unit of microbial biomass per unit of time. This parameter also indicates the degree of "stress" of the microbial community. Changes in soil biological parameters as a function of cover crops and soil management can be seen in Table 4.

In NT one should be aware of the effect on the proliferation of pathogenic fungi in the soil, due to the favorable microclimate provided with the maintenance of straw on the soil surface.

| Soil management system | C-Microbial biomass | N- Microbial biomass | Respiration rate | qCO ₂ |
|---------------------------|---------------------------------|---------------------------------|--|------------------|
| | (C-BM μg g soil ⁻¹) | (N-BM μg g soil ⁻¹) | (C-CO ₂ μg g solo ⁻¹ h ⁻¹) | |
| No-tillage (NT) | 292 | 32 | 6,9 | 0,027 |
| Conventional tillage (CT) | 262 | 29 | 8,1 | 0,045 |

Table 4. Carbon and nitrogen microbial biomass, respiration rate and metabolic quotient (qCO₂) in two soil management systems: no tillage (NT) and conventional tillage (CT). From: Adapted from Silva et al. (2007).

6. Suppression and weeds control by cover crops

The presence of mulch on the soil surface reduces the development of weeds, mainly due to physical impairment. Cover crops that result in greater amount of organic residues and with high C/ N ratios are more efficient in the management of invasive plants, by composing a thicker layer of mulch on the soil surface and a longer time of permanence. According to Oliveira et al. (2002), the number of weeds decreases linearly with increasing amount of organic residues on surface soil, as can be seen in Figure 13.

The maintenance of cover crops generates competition with weeds for water, light, CO₂, mainly physical space, leading to a delay in their development. Besides the suppression (physical effects) of cover crops on weeds, there is also the influence of chemical compounds released by plants, called allelopathic effect. According to Tokura & Nobrega (2006), the residual plant cover is of great importance on allelopathic weeds.

According to Moraes et al. (2010), the allelopathic effect depends on the amount of cover crop residues produced, on the weed species that can be observed in the soil seed bank, and on the time of decomposition of soil residues. Rao et al. (2003) observed that the slow decomposition of plant residues can lead to a longer period of allelopathy on weeds, provided that the critical levels of allelochemicals are achieved.

The allelochemicals present in plants can be released to soil via root exudation, volatilization, leaching and decomposition of plant residues. These compounds are water soluble and can remain in soil solution and be absorbed by the root system of weeds. The allelochemicals cause physiological and morphological changes, influencing processes such as germination, growth, flowering, fruiting, senescence and abscission sensitive species (Correia et al., 2005). Table 5 and Figure 14 show the effects of cover crops on the germination and development of *Bidens* sp. An important weed in the Cerrado, once they have arisen frequently resistant biotypes which are resistant to herbicides inhibiting acetolactate synthase (ALS), the main herbicides used to control this species.

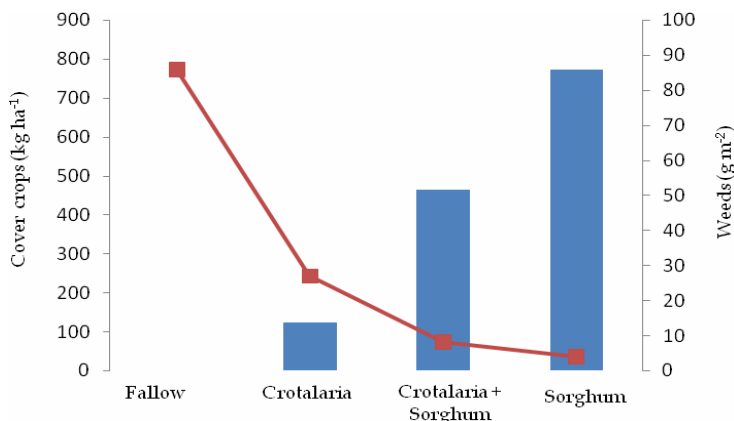

Fig. 13. Weed biomass reduction by the amount of cover crops residues on soil surface. From: Adapted from Goulart et al. (2009).

| Treatment | % Germination | GSI | % Germination reduction |
|-------------------------------|---------------|------|-------------------------|
| Fallow | 87,8 | 28,8 | 0,0 |
| <i>Cajanus cajan</i> | 82,2 | 28,0 | 6,3 |
| <i>Crotalaria spectabilis</i> | 75,5 | 20,9 | 14,0 |
| <i>Stylobium atterimum</i> | 67,9 | 19,0 | 22,6 |
| <i>Crotalaria juncea</i> | 56,6 | 19,4 | 35,5 |

Table 5. Germination percentage, germination speed index (GSI) and percentage reduction of the germination of achenes of *Bidens pilosa* under the effect of aqueous extracts of different plants as green manure. From: Adapted from Teixeira et al. (2004).

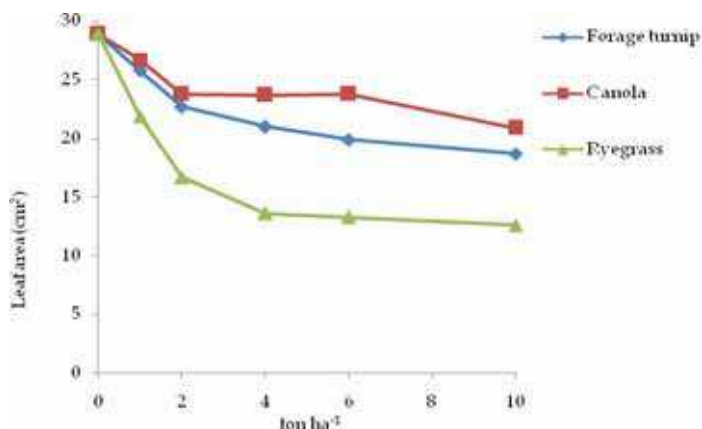

Fig. 14. Leaf area of *Bidens* sp., in different amount of cover crops residues on the soil surface. From: Adapted from Moraes et al. (2010).

7. Performance of soybean cropped under cover crops

The soybean productivity under different tillage systems depends among other factors, on climate, soil type, soil fertility, pest management, finally, on the technological level of dealing with crops.

The response of soybean to the NT becomes more evident in tropical weather conditions, such as the Cerrado, due to poor and naturally acid soil, low in organic matter, since there is a high microbial activity and often harsh conditions of humidity, which are often mitigated by the use of cover crops that help retain moisture, increase organic matter and therefore fertility, reduce soil temperature variation, increase microbial activity resulting in the release of plant nutrients and lower density layers throughout the soil profile. The increase in soil organic matter of humic substances can lead to the occurrence of the electrophysiological effect, which reduces the energy required by plants while absorbing nutrients, resulting in a higher amount of assimilates to be distributed to sinks (grain). According to Nardi et al. (2002), low molecular weight compounds derived from humic substances can aid the absorption of nutrients through the plasma membrane, such as NO_3^- . Some studies (Marcandali et al. 2010; Pacheco et al. 2009) have demonstrated the superiority of soybean when grown under NT. In the Cerrado, there has been highlighted as cover crop, the millet and brachiaria, providing the best yields for soybeans (Figure 15).

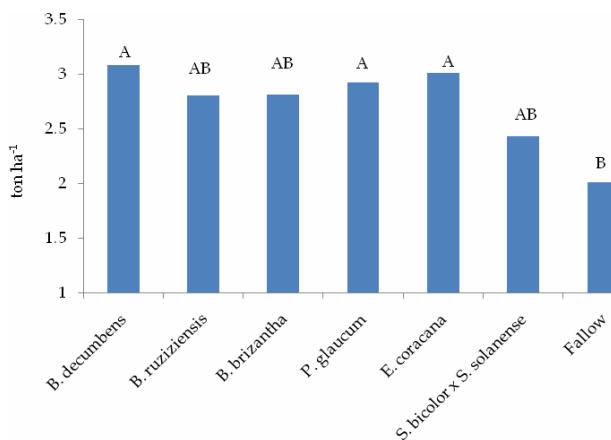

Fig. 15. Soybean productivity (ton ha⁻¹) grown under different cover crops. From: Adapted from Pacheco et al. (2009).

The capacity of cover crop species used in NT influences significantly in soybean production (Fig.16), since the higher covering rate is associated with higher biomass quantities, providing better building conditions to the soil.

The costs of implementing the NT initially raise production costs in comparison to conventional systems. The high initial cost of adopting the NT is due to the need for soil conditioning and the acquisition of appropriate machines (Fidelis et al., 2003). However, these costs are significant only in short term, because over the years (> 3 years) that cost becomes low when compared to conventional systems, if considered the benefits that the cover crop system provides to physical, chemical and biological soil attributes, thus increasing the revenue (Figure 17).

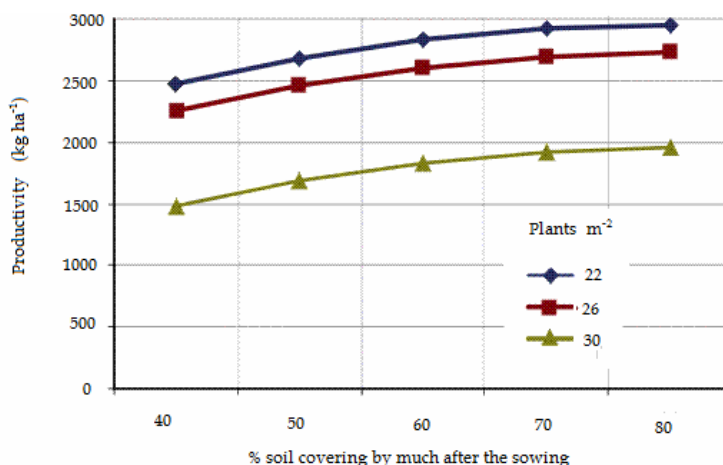

Fig. 16. Increased productivity of soybean due to higher mulch immediately after seeding it in no-till. From: Adapted from Medeiros & Calegari (2007).

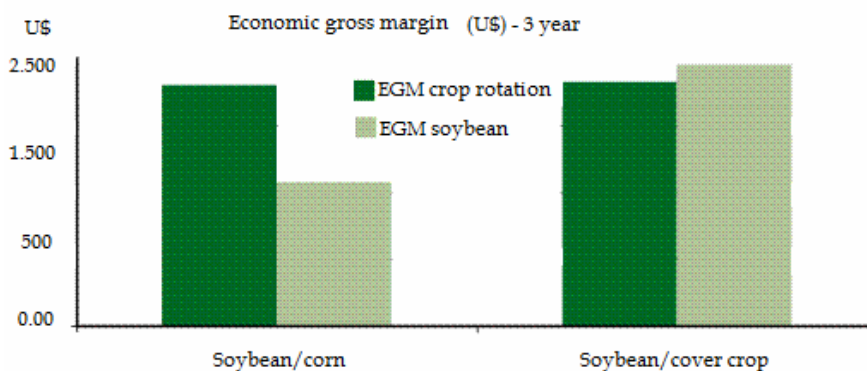

Fig. 17. Economic gross margin for soybean in two production systems, soybean/ corn in double-cropping and soybean/ cover crops in double-cropping, for three consecutive years. From: Adapted from Medeiros & Calegari (2007).

7. References

- Aita, C. & Giacomini, J (2003). Decomposição e liberação de nitrogênio de resíduos culturais de plantas de cobertura do solo solteiras e consorciadas. *Revista Brasileira de Ciência do Solo*, Vol.27, No.4, (July 2003), pp. 601-612, ISSN 0100-0683
- Aita, C. & Giacomini, J (2006). Plantas de cobertura de solo em sistemas agrícolas, In: *Manejo de sistemas agrícolas*, B.J.R. Alves; S. Urquiaga; C. Aita; R.M. Boddey; C.P. Jantalia & F.A.O. Camargo (Eds), 59-80, Genesis, ISBN 85-87578-13-8
- Amabile, R. F.; Fancelli, A. L. & Carvalho, A. M. (2000). Comportamento de espécies de adubos verdes em diferentes épocas de semeadura e espaçamentos na região dos

- cerrados. *Pesquisa Agropecuária Brasileira*, Vol.35, No.1, (January 2000), pp. 47-54, ISSN 0100-204X
- Amado, T. J. C., Bayer, C., Eltz, F. L. F. & Brum, A. C. R. (2001). Potencial de culturas de cobertura em acumular carbono e nitrogênio no solo no plantio direto e a melhoria da qualidade ambiental. *Revista Brasileira de Ciência do Solo*, V. 25, No. 1, (janeiro/ fevereiro 2001), pp. 189-197, ISSN 0100-0683.
- Anderson, T. H. & Domsch, K. H. (1993). The metabolic quotient for CO₂ (qCO₂) as a specific activity parameter to assess the effects of environmental conditions, such pH, on the microbial of forest soils. *Soil Biology and Biochemistry*, Elmsford, Vol.25, No.3, (March 1993), pp.393- 395, ISSN 0038-0717
- Andrews, J. A., Johnson, J. E. & Torbert, T. L. 1998. Minesoil and site properties associated with early height growth of eastern white pine. *Journal Environmental Quality*, Vol.27, No.1 (January 1998), pp. 192-199, ISSN 0047-2425
- Bell, J. C., Conningham, R. L. & Antony, C. T. (1994). Morphological characteristics of reconstructed prime farmland soils in western Pennsylvania. *Journal Environmental Quality*, Vol.23, No.3, (March 1994), p. 515-520, ISSN 0047-2425
- Bloom, A. J.; Smart, D. R.; Nguyen, D. T. & Searles, P. S. Nitrogen assimilation and growth of wheat under elevated carbon dioxide. (2002). *Plant Biology*, Vol.99, No.12, (December 2002), pp. 1730-1735, ISSN 1438-8677
- Boer, C. A.; Assis, R. L.; Silva, G. P.; Braz, A. J. B. P.; Barroso, A. L. L.; Cargnelutti Filho, A. & Pires, F. R. (2007). Ciclagem de nutrientes por plantas de cobertura na entressafra em um solo de cerrado. *Pesquisa Agropecuária Brasileira*, Vol.42, No.9, (September 2007), pp. 1269-1276, , ISSN 0100-204X
- Bordin, I.; Neves, C. S. V. J.; Francio Filho, P.; Preti, E. A. & Cardoso, C. (2008). Crescimento de milho e guandu, desempenho de plantas cítricas e propriedades físicas do solo escarificado em um pomar. *Revista Brasileira de Ciência do Solo*, Vol.32, No.4, (July 2008), pp. 1409-1418, , ISSN 0100-0683
- Braz, A. J. B. P.; Silveira, P. M. da; Kliemann, H. J & Zimmermann, F. J. P. (2004). Acumulação de nutrientes em folhas de milho e dos capins braquiária e mombaça. *Pesquisa Agropecuária Tropical*, Vol.34, No.1, (March 2004), pp. 83-87, ISSN 1983-4063
- Campos, B. C.; Reinert, D. J.; Nicolodi, R.; Ruedell, J & Petreire, C. (1995). Estabilidade estrutural de um latossolo vermelho-escuro distrófico após sete anos de rotação de culturas e sistemas de manejo de solo. *Revista Brasileira de Ciência do Solo*, Vol.19, No.1, (January 1995), pp. 121-126, ISSN 0100-0683
- Carneiro, M. A. C.; Souza, E. D.; Reis, E. F.; Pereira, H. S. & Azevedo, W. R. (2009). Atributos físicos, químicos e biológicos de solo de cerrado sob diferentes sistemas de uso e manejo. *Revista Brasileira de Ciência do Solo*, Vol.33, No.1, (January 2009), pp. 147-157, ISSN 0100-0683
- Carpenedo, V. & Mielniczuk, J (1990). Estado de agregação e qualidade dos agregados de Latossolos roxos, submetidos a diferentes sistemas de manejos. *Revista Brasileira de Ciência do Solo*, Vol.14, No.1 (January/ abril 1990), pp. 99-105, ISSN 0100-0683
- Carpim, L.; Assis, R. L.; Braz, A. J. B. P.; Silva, G. P.; Pires, F. R.; Pereira, V. C.; Gomes, G. V. & Silva, A. G. (2008). Liberação de nutrientes pela palhada de milho em diferentes estádios fenológicos. *Revista Brasileira de Ciência do Solo*, Vol.32, No. spe, (October 2008), pp. 2813-2819, ISSN 0100-0683

- Conab – Companhia Nacional de Abastecimento. (March 2009). 11^o Levantamento da Produção de Grãos – Safra 2008/ 09. In; CONAB, 27.03. 2009, Available from:< [http:// www.conab.gov.br](http://www.conab.gov.br)>. Acesso em: 27 mar. 2009.
- Correia, N. M., Centurion, M. A. P. C. & Alves, P. L. C. A. (2005). Influência de extratos aquosos de sorgo sobre a germinação e o desenvolvimento de plântulas de soja. *Ciência Rural*, Vol.35, No.3, (May/ june2005), pp.498-503, ISSN 0103-8478
- Costa, F. S.; Bayer, C.; Albuquerque, J. A. & Fontoura S. M. V. (2004). Aumento de matéria orgânica num latossolo bruno em plantio direto. *Ciência Rural*, Vol.34, No.2, (April 2004), pp. 587-589, ISSN 0103-8478
- Crawford, N. M. (1995). Nitrate: nutrient and signal for plant growth. *The Plant Cell*, Vol.7, No.7, (July 1995), pp. 859-868, ISSN 1532-298X
- Crusciol, C. A. C.; Cottica, R. L.; Lima, E. V.; Andreotti, M.; Moro, E. & Marcon, E. (2005). Persistência de palhada e liberação de nutrientes do nabo forrageiro no plantio direto. *Pesquisa Agropecuária Brasileira*, Vol.40, No.2, (February 2005), pp. 161-168, ISSN 0100-204X
- De-Polli, H. & Pimentel, M. S. (2005). Indicadores de qualidade do solo, In: *Processos biológicos no sistema solo-planta: ferramentas para uma agricultura sustentável* Aquino, A. M.; Assis, R. L. (Ed), pp. 17-28, ISBN 85-7383-304-1, Embrapa-SCT, Brasília, Brazil.
- Derpsch, R., Roth, C. H., Sidiras, N. & Kopke, U. (1991). *Controle da erosão no Paraná*, GTZ, ISBN 3-88085-433-5, Eschborn, Germany
- Dexter, A. R. (2004). Soil physical quality: Part II. Friability, tillage, tilth and hard-setting. *Geoderma*, Vol.120, No.3-4, (June 2004), pp.215-225, ISSN 0016-7061.
- Espindola, J. A. A.; Guerra, J. G. M.; Almeida, D. L.; Teixeira, M. G. & Urquiaga, S. (2006). Decomposição e liberação de nutrientes acumulados em leguminosas herbáceas perenes consorciadas com bananeira. *Revista Brasileira de Ciência do Solo*, Vol.30, No.2, (March 2006), pp. 321-328, ISSN 0100-0683
- Falleiro, R. M.; Souza, C. M.; Silva, C. S. W.; Sediyaama, C. S.; Silva, A. A. & Fagundes, J. L. (2003). Influência dos sistemas de preparo nas propriedades químicas e físicas do solo. *Revista Brasileira de Ciência do Solo*, Vol.27, No.6, (November 2003), pp. 1097-1104, ISSN 0100-0683
- Favero, C., Jucksch, I., Costa, L. M., Alvarenga, R. C. & Neves, C. L. (2000). Crescimento e acúmulo de nutrientes por plantas espontâneas e por leguminosas utilizadas para adubação verde. *Revista Brasileira de Ciência do Solo*, Vol.24, No.1, (January/ april 2000), pp. 171-177, ISSN 0100-0683
- Febrapdp – Federação Brasileira de Plantio Direto na Palha. (October 2009). Desenvolvimento do Plantio Direto. In: *FEBRAPD*, 03.10.2009. Available from:< [http:// www.febrapdp.org.br](http://www.febrapdp.org.br)>
- Fidelis, R. R., Rocha, R. N. C., Leite, V. T. & Tancredi, F. D. (2003). Alguns aspectos do Plantio Direto para a cultura da soja. *Bioscience Journal*, Vol.19, No.1, January/ april 2003), pp. 23-31, ISSN 1981-3163
- Franchini, J. C., Malavolta, E., Miyazawa, M. & Pavan, M. A. (1999). Alterações químicas em solos ácidos após a aplicação de resíduos vegetais. *Revista Brasileira de Ciência do Solo*, Vol.23, No.3, (September/ december 1999), pp. 533-542, ISSN 0100-0683
- Franco, A. A. & Campello, E. F. C. (2005). Manejo integrado na recuperação de áreas degradadas e na sustentabilidade de sistemas produtivos utilizando a fixação biológica de nitrogênio como fonte de nitrogênio, In: *Processos biológicos no sistema*

- solo-planta: Ferramentas para uma agricultura sustentável*, Aquino, A. M. & Assis, R. L., pp. 201-220, Embrapa Informação Tecnológica, ISBN: 85-7383-304-1, Brasília, Brazil
- Gama-Rodrigues, A. C.; Gama-Rodrigues, E. F. & Brito, E. C. (2007). Decomposição e liberação de nutrientes de resíduos culturais de plantas de cobertura em argissolo vermelho-amarelo na região Noroeste Fluminense (RJ). *Revista Brasileira de Ciência do Solo*, Vol.31, No.6, (November 2007), pp. 1421-1428, ISSN 0100-0683
- Giacomini, S. J.; Aita, C.; Hubner, A. P.; Lunkes, A.; Guidini, E. & Amaral, E. B. (2003) Liberação de fósforo e potássio durante a decomposição de resíduos culturais em plantio direto. *Pesquisa Agropecuária Brasileira*, Vol.38, No.9, (September 2003), pp. 1097-1104, ISSN 0100-204X
- Gonçalves, W. G.; Jimenez, R. L.; Araújo Filho, J V.; Assis, R. L.; Silva, G. P. & Pires, F. R. (2006). Sistema radicular de plantas de cobertura sob compactação de solo. *Engenharia Agrícola*, Vol.26, No.1, (January 2006), pp. 67-75, ISSN 0100-6916.
- Goulart, P., Campos, S., Bastiani, M., Moreira, G. & Pereira, L. (2009). Desempenho da Biomassa das Plantas de Cobertura de Verão na Supressão de Plantas Espontâneas. *Revista Brasileira De Agroecologia*, Vol. 4, No. 2, (novembro 2009), p. 3494-3498, ISSN 1980-9735.
- Heinrichs, R., Vitti, G. C., Moreira, A., Figueiredo, P. A. M., Fancelli, A. L. & Corazza, E. J. (2005). Características químicas de solo e rendimento de fitomassa de adubos verdes e de grãos de milho, decorrente do cultivo consorciado. *Revista Brasileira de Ciência do Solo*, V. 29, No. 1, (January/ february 2005) pp. 71-79, ISSN 0100-0683
- Henriksen, I.; Michelsen, A. & Scholtonvoigt, A. (2002). Tree species selection and soil tillage in alley cropping systems with *Phaseolus vulgaris* L. in a humid premontane climate: biomass production, nutrient cycling and crop responses. *Plant Soil*, Vol.240, No.1, (January 2002), pp. 145-159, ISSN 1573-5036
- Karlen, D. L., Mausbach, M. J., Doran, J W., Cline, R. G., Harris, R. F. & Schuman, G. E. (1997). Soil quality: a concept, definition, and framework for evaluation. *Soil Science Society of America Journal*, V. 61, No. 01, (January 1997), pp. 4-10, ISSN 0361-5995
- Kluthcouski, J.; Fancelli, A. L.; Dourado-Neto, D.; Ribeiro, C. R. & Ferraro, A. (2000). Manejo do solo e o rendimento de soja, milho, feijão e arroz em plantio direto. *Scientia Agrícola*, Vol.57, No.1, (January 2000), pp. 97-104, ISSN 0103-9016
- Kluthcouski, J & Stone, L. F. (2003). Manejo Sustentável dos Solos do Cerrado, In: *Integração Lavoura-Pecuária*, Kluthcouski, J, Stone, L. F. & Aidar, H., pp. 61-104, Embrapa Arroz e Feijão, ISBN 85-7437-018-5, Santo Antônio de Goiás, Brazil
- Kluthcouski, J. (1998). *Efeito do manejo em alguns atributos de um latossolo roxo sob cerrado e nas características produtivas de milho, soja, arroz e feijão, após oito anos de plantio direto*. 170 f. Thesis (Agronomy). Escola Superior de Agricultura "Luiz de Queiroz"
- Machado, L. A. Z. & Assis, P. G. G. (2010). Produção de palha e forragem por espécies anuais e perenes em sucessão à soja. *Pesquisa Agropecuária Brasileira*, Vol.45, No.4, (April 2010), pp. 415-422, ISSN 0100-204X
- Marcandali, L. H., Lazarini, E., Franzola, F. H., Oliveira, W. A. S. & Hayashi, F. K. (2010). Sistema Plantio Direto com Soja: características agrônomicas e produtividade, *Proceedings of XXIX Reunião Brasileira de Fertilidade do Solo e Nutrição de Plantas*. Guarapari, ES, Brazil, 13-17 september 2010

- Medeiros, G. B. & Calegari, A. (2007). Sistema Plantio Direto com qualidade: a importância do uso de plantas de cobertura num planejamento cultural estratégico. *Revista Plantio Direto*, Ed. 102, (November/ december 2007)
- Menezes, L. A. S. & Leandro, W. M. (2004). Avaliação de espécies de coberturas do solo com potencial de uso em sistema de plantio direto. *Pesquisa Agropecuária Tropical*, Vol.34, No.3, (September 2004), pp. 173-180, ISSN 1983-4063
- Moraes, P. V. D., Agostinetto, D., Panozzo, L. E., Brandolt, R., Tironi, S. P., Oliveira, C. & Markus, C. (2010). Efeito alelopático de plantas de cobertura, na superfície ou incorporadas ao solo, no controle de picão-preto. *Revista da Faculdade de Zootecnia, Veterinária Agronomia da Pontifícia Universidade Católica de Uruguaiana*, V. 17, No. 1, (January/ march 2010), pp. 51-67, ISSN 0104-4257
- Moreira, J. A. A., Aguiar, R. A., Stone, L. F., Bernardes, T. G., Pereira Filho, I. A. & Cruz, J. C. (2009). Efeito de Diferentes Plantas de Cobertura do Solo Sobre Alguns Atributos do Solo em Sistema de Produção Orgânico. *Revista Brasileira de Agroecologia*, V. 4, No. 2, (January 2009), pp. 3748-3751, ISSN 1980-9735
- Nardi, S.; Pizzeghello, D.; Muscolo, A.; Vianello, A. (2002). Physiological effects of humic substances on higher plants. *Soil Biology & Biochemistry*, V.34, No.11, (November 2002), pp. 1527-1536, ISSN 0038-0717
- Oliveira, T. K. de., Carvalho, G. J. & Moraes, R. N. S. (2002). Plantas de cobertura e seus efeitos sobre o feijoeiro em plantio direto. *Pesquisa Agropecuária Brasileira*, V.37, No.8, (August 2002), pp. 1079-1087, ISSN 1678-3921.
- Pacheco, L. P. (2009a). Arroz de terras altas cultivado em sucessão a plantas de cobertura em sistemas de manejo do solo. PhD Thesis (Crop Production), (December 2009), Federal University of Goiás, Brazil
- Pacheco, L. P.; Pires, F. R.; Monteiro, F. P.; Procópio, S. O.; Assis, R. L.; Carmo, M. L. & Petter, F. A. (2008) Desempenho de plantas de cobertura em sobressemeadura na cultura da soja. *Pesquisa Agropecuária Brasileira*, Vol.43, No.7, (July 2008) pp. 815-823, ISSN 0100-204X
- Pacheco, L.P.; Pires, F.R.; Monteiro, F.P.; Procópio, S.O.; Assis, R.L.; Cargnelutti Filho, A.; Carmo, M.L. & Petter, F.A. (2009b). Sobressemeadura da soja como técnica para supressão da emergência de plantas daninhas. *Planta Daninha*, Vol.27, No.3, (September 2009), pp. 455-463, ISSN 0100-8358
- Pereira, F. A. R. & Velini, E. D. (2003) Sistemas de cultivo no cerrado e dinâmica de populações de plantas daninhas. *Planta Daninha*, Vol.21, No.3, (September 2003), pp. 355-363, ISSN 0100-8358
- Portes, T. A.; Carvalho, S. I. C.; Oliveira, I. P. & Kluthcouski, J. (2000). Análise do crescimento de uma cultivar de braquiária em cultivo solteiro e consorciado com cereais. *Pesquisa Agropecuária Brasileira*, Vol.35, No.7, (July 2000), pp. 1349-1358, ISSN 0100-204X
- Rezende, C. P., Pinto, J. C. & Evangelista, A. R. (2003). Alelopatia e suas interações na formação e manejo de pastagens. *Boletim agropecuário*, pp.1-55, No.54, Lavras, MG, Brazil.
- RicharT, A., Tavares Filho, J., Brito, O. R., Llanillo, R. F. & Ferreira, R. (2005). Compactação do solo: causas e efeitos. *Semina: Ciências Agrárias*, Vol.26, No.3, (July/ september 2005), pp. 321-344, ISSN 0101-3742.

- Sá, J. C. de M. (1993). Manejo da fertilidade do solo no Sistema Plantio Direto, In: *Embrapa – Centro Nacional de Pesquisa de Trigo*, pp. 37-60, Embrapa Trigo, Passo Fundo, RS, Brazil.
- Salet, R. L. (1998). *Toxidez de alumínio no sistema plantio direto*. Thesis (Agronomy). Federal University of Rio Grande do Sul, Porto Alegre, RS, Brazil.
- Santos, H. P. & Siqueira, O. J. W. (1996). Plantio direto e rotação de culturas para cevada: efeitos sobre a fertilidade do solo. *Revista Brasileira de Ciência do Solo*, Vol.20, No.2, (May/ august 1996), pp.163-169, ISSN 0100-0683
- Severino, F. J.; Carvalho, S. J. P. & Christoffoleti, P. J (2006). Interferências mútuas entre a cultura do milho, espécies forrageiras e plantas daninhas em um sistema de consórcio. II – Implicações sobre as espécies forrageiras. *Planta Daninha*, Vol.24, No.1, (January 2006), pp. 45-52, ISSN 0100-8358
- Silva, M. B., Kliemann, H. J., Silveira, P. M. & Lanna, A. C. (2007). Atributos biológicos do solo sob influência da cobertura vegetal e do sistema de manejo. *Pesquisa Agropecuária Brasileira*, Vol.42, No.11, (November 2007), pp.001-007, ISSN 1678-3921
- Stone, L. F. & Silveira, P. M. (1999). Efeitos do sistema de preparo na compactação do solo, disponibilidade hídrica e comportamento do feijoeiro. *Pesquisa Agropecuária Brasileira*, Vol.34, No.1, (January 1999), pp. 83-91,ISSN 0100-204X
- Sumner, M. E. & Pavan, M. A. (2000). Alleviating soil acidity through organic matter management, *Proceedings of 3º Simpósio sobre Rotação Soja/Milho no Plantio Direto*, Piracicaba, 3-5 julho 2000
- Teixeira, C. M., Araújo, J. B. S. & Carvalho, G. J (2004). Potencial alelopático de plantas de cobertura no controle de picão-preto (*Bidens pilosa* L.). *Ciência e Agrotecnologia*, Vol.28, No.3, (May/ June 2004), pp. 691-695, ISSN 1413-7054
- Testa, V. M., Teixeira, L. A. J. & Mielniczuk, J (1992). Características químicas de um Podzólico vermelho escuro afetadas por sistemas de culturas. *Revista Brasileira de Ciência do Solo*, Vol.16, No.2, (May/ august 1992), pp. 107-114, ISSN 0100-0683
- Timossi, P.C.; Durigan, J.C. & Leite, G.J (2007). Formação de palhada por braquiárias para adoção do sistema plantio direto. *Bragantia*, Vol.66, No.4, (October 2007), pp. 617-622, ISSN 0006-8705
- Tokura, L. K. & Nobrega, L. H. P. (2006). Alelopatia de cultivos de cobertura vegetal sobre plantas infestantes. *Acta Scientia Agronômica*, Vol.28, No.3, (October/ december 2006), pp. 379-384, ISSN 1679-9275
- Torres, J.L.R.; Pereira, M.G.; Andrioli, I.; Polidoro, J.C. Fabian, A.J (2005). Decomposição e liberação de nitrogênio de resíduos culturais de plantas de cobertura em um solo de cerrado. *Revista Brasileira de Ciência do Solo*, Vol.29, No.4, (July 2005), pp. 609-618, ISSN 0100-0683
- Torres, J.L.R.; Pereira, M.G. & Fabian, A.J (2006). Produção de fitomassa por plantas de cobertura e mineralização de seus resíduos em plantio direto. *Pesquisa Agropecuária Brasileira*, Vol.43, No.3, (March 2008), pp. 421-428, ISSN 0100-204X
- Vieira, M. J 1985. Comportamento físico do solo em plantio direto, In: *Atualização em plantio direto*, Fancelli, A. L., Torrado, P. V. & Machado, J, pp. 163-179, Fundação Cargil, Campinas, Brazil.

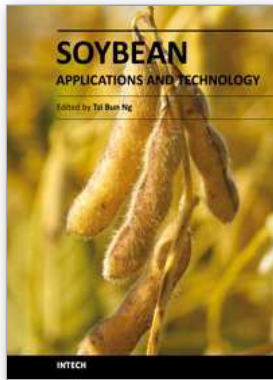

Soybean - Applications and Technology

Edited by Prof. Tzi-Bun Ng

ISBN 978-953-307-207-4

Hard cover, 402 pages

Publisher InTech

Published online 26, April, 2011

Published in print edition April, 2011

Soybean is an agricultural crop of tremendous economic importance. Soybean and food items derived from it form dietary components of numerous people, especially those living in the Orient. The health benefits of soybean have attracted the attention of nutritionists as well as common people.

How to reference

In order to correctly reference this scholarly work, feel free to copy and paste the following:

Pacheco, Leandro Pereira and Petter, Fabiano André (2011). Benefits of Cover Crops in Soybean Plantation in Brazilian Cerrados, Soybean - Applications and Technology, Prof. Tzi-Bun Ng (Ed.), ISBN: 978-953-307-207-4, InTech, Available from: <http://www.intechopen.com/books/soybean-applications-and-technology/benefits-of-cover-crops-in-soybean-plantation-in-brazilian-cerrados>

INTECH

open science | open minds

InTech Europe

University Campus STeP Ri
Slavka Krautzeka 83/A
51000 Rijeka, Croatia
Phone: +385 (51) 770 447
Fax: +385 (51) 686 166
www.intechopen.com

InTech China

Unit 405, Office Block, Hotel Equatorial Shanghai
No.65, Yan An Road (West), Shanghai, 200040, China
中国上海市延安西路65号上海国际贵都大饭店办公楼405单元
Phone: +86-21-62489820
Fax: +86-21-62489821

© 2011 The Author(s). Licensee IntechOpen. This chapter is distributed under the terms of the [Creative Commons Attribution-NonCommercial-ShareAlike-3.0 License](#), which permits use, distribution and reproduction for non-commercial purposes, provided the original is properly cited and derivative works building on this content are distributed under the same license.

The Effect of Technological Processing on the Content of Isoflavones in Bovine Milk and Dairy Products

Ludmila Křížová¹, Jiří Trínáctý², Jana Hajšlová³ and Šárka Havlíková⁴

¹Research Institute for Cattle Breeding, Ltd.

²Agriresearch Rapotín Ltd.

³The Institute of Chemical Technology, Prague, ⁴MILCOM a.s.
Czech Republic

1. Introduction

Isoflavones that belong to a class of phytoestrogens have a relatively limited distribution in nature and from the aspects of human nutrition they are found in physiologically relevant amounts only in soybeans and soybean-derived foods (Franke et al., 1998). Isoflavones are phytoalexins that are formed by the host plant in response to physiological or biological stimuli and possess properties (i.e. antifungal, antimicrobial, and antioxidant) that enhance the survival of the soybean (Dakora & Phillips, 1996). For this reason, soybean isoflavone concentrations increase greatly in times of stress (e.g. limited moisture) and are influenced by the environmental conditions under which the soybean is grown (Eldridge & Kwolek, 1983, Wang & Murphy, 1994).

The major dietary phytoestrogens present in soya (*Glycine max* (L.) Merr.) are daidzein, genistein and glycitein. After ingestion these substances are subjected to biotransformation by gut microbiota to diverse metabolites that can be detected in human urine (Joannou et al., 1995, Lampe et al., 1998, Coldham et al., 1999, Rowland et al., 1999, Hur et al., 2000, Heinonen et al., 2003, Zheng et al., 2003, Simons et al., 2005). While glycitein has been found to be metabolically stable (Setchell et al., 2002), genistein is converted to 6'-hydroxy-O-desmethylangolensin, 2,4,6-trihydroxybenzoic acid and p-ethyl phenol (Heinonen et al., 1999, Steer et al., 2003, Wähälä et al., 1998), daidzein is metabolised by intestinal microflora to equol and O-desmethylangolensin (Heinonen et al., 1999, Adlercreutz et al., 1986). Especially equol has gained a lot of attention since Setchell et al. (2002) proposed a hypothesis that the ability to biotransform daidzein to equol may be the key factor to clinical effectiveness of soy protein in cardiovascular, bone, and menopausal health in so-called equol producers. Indeed, recent studies found that equol is *in vitro* more bio-active than its precursor daidzein: it has a higher oestrogenicity (Kostelac et al., 2003, Setchell et al., 2002, Morito et al., 2001, Muthyala et al., 2004, Sathyamoorthy & Wang, 1997, Schmitt et al., 2001), is a more potent anti-oxidant (Arora et al., 1998, Mitchell et al., 1998, Rimbach et al., 2003, Turner et al., 2004) and possesses anti-androgenic properties (Lund et al., 2004). Furthermore, equol has a higher effective free fraction circulating in human serum (Nagel et al., 1999) and a slower plasma clearance (Setchell et al., 2002) compared to daidzein.

As mentioned above, equol is not of plant origin and is exclusively formed by the intestinal microbiota (Atkinson et al., 2004, Blair et al., 2003, Bowey et al., 2003, Hoey et al., 2004). Studies (e.g. Lampe et al., 1998, Rowland et al., 2000) have shown that there are substantial inter-individual variations in the bacterial metabolism of isoflavones in the gut resulting in a low proportion of adult population (30 – 50 %) that is able to convert daidzein into equol (Atkinson et al., 2005). However, an alternative strategy for obtaining the health-promoting benefits of equol is oral administration. Setchell et al. (2002) has reported that an oral dose of 25 mg of equol was rapidly absorbed with maximum plasma concentration observed after 4 - 6 h. Walsh et al. (2003) and Walsh & Faila (2009) have found that equol is stable during simulated gastric and small intestinal digestion and is readily bioaccessible. This further supports the beneficial potential of orally administered equol to individuals classified as equol “non-producers”. From the range of foods commonly consumed by humans, cow’s milk is presumably the only nutritive that can contain appreciable amounts of equol itself (Mustonen et al., 2009, Steinshamn et al., 2008) thus bovine milk can be considered as a potential source of equol for non-equol producers. Furthermore, in a recent study, Kuhnle et al. (2008) reported low content of equol in various commercially available dairy products except butter. Thus, not only milk but also dairy products could be a source of equol in a human diet.

Although changes in isoflavones content during technological processing of soybean based products are extensively studied (e.g Prabhakaran & Perera, 2006, Uzzan & Labuza, 2004, Jackson et al., 2002), studies focused on changes in isoflavones, especially equol, during technological processing of bovine milk are scarce. To our knowledge, only effect of heat treatment on milk isoflavones has been reported previously. King et al. (1998) found no effect of pasteurization on concentration of equol and genistein in milk. Similarly, Uzzan & Labuza (2004) determined no effect of heat treatment at 72, 121, 140 and 140 °C for 120, 24, 2 and 20 sec, respectively on content of daidzein, genistein and glycitein in an isoflavone-enriched cow milk beverage.

The aim of the study was to determine possible changes in isoflavones content in milk and dairy products during technological processing.

2. Material and methods

2.1 Animals and diets

The experiment was carried out on four high-yielding lactating Holstein cows (lactation 2, 22 – 26. week of lactation) with similar milk production (18.0 ± 1.1 kg/d) that were divided into 2 groups with similar milk yield. The control group of animals was fed a diet based on extruded rapeseed cake (C) while the experimental group of animals was fed a diet based on extruded full-fat soya (S). The experiment was carried out in the form of a cross-over design and was divided into 2 periods of 14 days. Each period consisted of a 10-d preliminary period and a 4-d experimental period. Cows were fed individually twice daily (6.30 and 16.30 h) *ad libitum* the diet based on maize silage, lucerne hay and supplemental mixture (Table 1). Prior the experiment there was at least a 1-week period to adaptation to the type of diet.

Cows were milked twice a day (7.00 and 17.00 h). Milk yield was recorded at each milking. During the experimental period, samples of milk were taken at each milking. Samples for determination of basic constituents were conserved by 2-bromo-2-nitropropane-1,3-diol (Bronopol; D&F Control Systems, Inc. USA), cooled to the 6 °C and analysed by infrared analyser (Bentley Instruments 2000, Bentley Instruments Inc., USA). Milk samples for determination of isoflavones concentration were kept frozen at -20 °C.

| Components | | C | S |
|---|------|--------|--------|
| Maize silage | g/kg | 508 | 508 |
| Lucerne hay | g/kg | 92 | 92 |
| Supplemental mixture C | g/kg | 400 | 200 |
| Supplemental mixture S | g/kg | | 200 |
| Composition of supplemental mixtures | | | |
| Barley | g/kg | 266.0 | 266.0 |
| Oat | g/kg | 266.0 | 266.0 |
| Sugarbeet chippings | g/kg | 150.0 | 96.0 |
| Extruded full-fat soya | g/kg | | 336.0 |
| Extruded rapeseed cake | g/kg | 282.0 | |
| Rapeseed oil | g/kg | 10.5 | |
| Sodium chloride (NaCl) | g/kg | 5.5 | 4.0 |
| Dicalciumphosphate (DCP) | g/kg | 7.5 | 14.0 |
| Limestone (CaCO ₃) | g/kg | 10.5 | 11.6 |
| Sodium bicarbonate (NaHCO ₃) | g/kg | 1.0 | 4.5 |
| Magnesiumphosphate (MgP) | g/kg | | 0.9 |
| Blend-s minerals | g/kg | 0.5 | 0.5 |
| Blend-s vitamins | g/kg | 0.5 | 0.5 |
| Total | g/kg | 1000.0 | 1000.0 |

Table 1. Composition of diet (g/kg, dry matter basis)

In each period a 20 kg of morning milk was collected from each group for technological processing. Milk was centrifuged on EleCrem 1 (Elecrem, France) to remove solid impurities and to separate cream from skim milk. After centrifugation skim milk and cream was recombined to obtain again full-fat milk. Full-fat milk was pasteurised at 65 °C for 30 min and used for manufacturing of plain yoghurt without any other ingredients. Pasteurised milk was warmed up to temperature of 37 °C, inoculated with a 1% of yoghurt cultures KAN IV (*Streptococcus thermophilus*, *Lactobacillus delbrueckii subsp. bulgaricus*, MILCOM a.s., Czech Republic) and packed into sterile bottles (180 ml volume) with twist-off lid and maintained in the thermoregulator at 37 °C for 16 – 18 h until coagulation. Then the coagulated products were cooled and stored in the thermoregulator at 6.5 °C for 1 month. During the above described technological processing samples were taken to determine isoflavones content.

2.2 Analytical procedures

Dry matter of feeding components was determined by drying at 55 °C for 24 h, followed by milling through a 1 mm screen and drying for another 4 h at 103 °C.

Dry matter content of milk and dairy products was determined according to czech national standards by drying sample with laboratory silica sand at 102 °C until constant weight.

Determination of isoflavones in feed and milk has been described previously (Třináctý et al., 2009). Briefly, levels of targeted compounds were determined after their releasing from bonded forms. High purity standards of daidzein (≥98%), glycitein (≥97%) and genistein (≥95%) were purchased from Sigma-Aldrich (Germany), equol (≥99%) and internal standard 4-hydroxybenzofenon (4-HBPE) (≥99%) were purchased from Fluka (Germany).

Feed samples: Homogenised samples were hydrolysed with 6 mol/l hydrochloric acid and ethanol under the reverse condenser at the boiling point of ethanol. After hydrolysis the

extract was cleaned up by SPE procedure on Oasis HLB, Waters (UK) cartridges. The analytical column used for experiments was LichroCART LiChrospher 100 RP8 (250×4 mm, 5 µm) with analytical precolumn LichroCART LiChrospher 100 RP8 (4×4 mm, 5 µm) (Merck, Germany). Mobile phase methanol and 0.1% acetic acid water solution (v/v) with gradient elution at a flow-rate 0.7 ml/min was used. The absorption maxima using for detection of total daidzein, glycitein and genistein was 260 nm. The HPLC analysis was carried out on an HP 1200 liquid chromatograph coupled with a diode array detector (DAD) (Hewlett Packard, USA). The limit of detection (LOD) for total isoflavones obtained under the described method was 0.5 mg/kg for daidzein, 0.5 mg/kg for glycitein, and 0.4 mg/kg for genistein. The repeatability expressed as a relative standard deviation (RSD%, n=6) was 6%, 3% and 3%, respectively.

Milk and milk products samples: Target analytes were hydrolysed from possible conjugates by enzymatic hydrolysis with Helix pomatia enzyme β-glucuronidase/sulfatase in sodium acetate buffer (pH 5) at 37 °C. After hydrolysis the analytes were extracted by ethylacetate. The analytical column used for experiments was Discovery C18, (150×3 mm, 5 µm) with analytical precolumns Discovery C18 Guard column (20×4 mm, 5 µm) (Supelco, Germany). Mobile phase methanol and 0.1% acetic acid water solution (v/v) with gradient elution at a flow-rate 0.7 ml/min was used. For MS/MS detection APCI at positive ionization mode was used with monitoring of transitions (*m/z*) 255.3 → 199.3 for daidzein, 285.3 → 270.2 for glycitein, 271.4 → 215.3 for genistein, 243.1 → 123.1 for equol, and 199.2 → 121.2 for 4-HBPE. Analytes were quantified by the method of internal standard. Liquid chromatograph HP 1100, (Hewlett Packard, USA) coupled with mass spectrometry detector - ion trap, Finnigan LCQ Deca, (Finnigan, USA) operated in selected reaction monitoring (SRM) mode was used for analysis. The limit of detection (LOD) obtained under the described method was 2 ng/ml for daidzein and glycitein, 5 ng/ml for genistein, and 0.7 ng/ml for equol for both milk and milk products samples. The repeatability expressed as relative standard deviation (RSD%, n=6) was 5% for daidzein, 7% for genistein and equol, and 4% for glycitein in milk and milk products samples.

2.3 Calculations

Mean daily intake of isoflavones was calculated from the analytically determined isoflavones concentrations of individual dietary components (silage, hay, supplemental mixture) and their respective intakes. When the concentration of isoflavones was so low that it could not be detected, the concentration was estimated to be half the detection limit before statistical analysis.

Apparent recovery of phytoestrogens from feed to milk was calculated according to the following formulas (based on Steinshamn et al., 2008):

Recovery of daidzein [µg/mg] = (sum of daidzein and equol secreted in milk)/sum of daidzein intake

Recovery of genistein [µg/mg] = sum of genistein secreted in milk/sum of genistein intake

Recovery of glycitein [µg/mg] = sum of glycitein secreted in milk/sum of glycitein intake

2.4 Statistical analysis

Data concerning the nutrients intake, milk yield, concentration, output and recovery of isoflavones obtained in the experiment were analysed using the GLM procedure of the

Statgraphics 7.0 package (Manugistics Inc. and Statistical Graphics Corporation, Rockville, Maryland, USA) according to the following model:

$$Y_{ijkl} = \mu + T_i + C_j + P_k + D_l + \varepsilon_{ijkl}$$

where μ = general mean, T_i = treatment effect ($i = 2$), C_j = cow effect ($j = 4$), P_k = period effect ($k = 2$), D_l = day of sampling effect ($l = 4$) and ε_{ijkl} = error term.

3. Results and discussion

3.1 Nutrient intake, milk yield, concentration, output and recovery of isoflavones in milk

The average daily intake of dry matter and isoflavones is presented in Table 2.

| Intake of | Units | C | S | SEM | P |
|-------------------|-------|-------------|---------------|-------|---------|
| Dry matter | kg/d | 16.8 | 17.8 | 0.28 | 0.01 |
| Daidzein | mg/d | 1.1 | 438.7 | 7.62 | < 0.001 |
| Genistein | mg/d | 0.8 | 681.8 | 11.44 | < 0.001 |
| Glycitein | mg/d | 1.1 | 164.2 | 5.18 | < 0.001 |
| Isoflavones total | mg/d | 2.9 | 1284.7 | 24.24 | < 0.001 |

Table 2. Average daily intake of dry matter and isoflavones

Various soybean products are commonly used as a dietary component of diets for high yielding dairy cows as an excellent source of high-quality protein and energy (Chouinard et al. 1997), however soybeans are also the richest source of isoflavones (Hollman, 2001) containing up to 1.2 – 4.2 mg/g dry weight of isoflavones (Kurzer & Xu, 1997). Intake of dry matter in S was higher than in C ($P < 0.05$). The concentration of isoflavones in extruded rapeseed cake and individual dietary components was under the sensitivity level of used analytical method (see Material and methods), however very low intake of isoflavones was calculated. Mean concentrations of isoflavones in extruded full-fat soya used in the present experiment were as follows: daidzein 377.9 mg/kg, genistein 558.2 mg/kg and glycitein 129.6 mg/kg, resulting in average total isoflavones intake of 1285 mg/d in S. Although concentration of individual isoflavones was considerably higher than that used in our previous study (Třináciý et al., 2009), average daily isoflavones intake in S was lower than in above mentioned work. This discrepancy can be explained by lower proportion of extruded full-fat soya in experimental diet.

Milk yield and isoflavones concentration, output and apparent recovery in milk is given in Table 3. Although milk yield in S was higher than in C ($P < 0.05$), milk yield expressed in 4% FCM (fat corrected milk) did not differ significantly between groups ($P > 0.05$). This is in accordance with e. g. Komprda et al. (2000) or Kudrna & Marounek (2006) who did not find a difference in milk yield between cows receiving rapeseed cake and extruded soybean meal or extruded soybeans, respectively. All studied isoflavones were detected in milk of both groups, C and S. While concentrations of daidzein and genistein were similar in both groups and were not affected by the treatment ($P > 0.05$), concentrations of equol and glycitein were higher ($P < 0.001$) in S than in C, resulting in higher daily output of daidzein, glycitein, equol and total isoflavones in S compared to C ($P < 0.01$). Findings concerning the differences in milk concentrations of genistein and equol between experimental groups are in accordance with Třináciý et al. (2009). However, based on the latter study, the concentration of equol in

milk in S was considerably lower than expected. A probable explanation to this discrepancy could be a lower rumen degradability of extruded full-fat soya currently used in the experiment in comparison with other extruded soybean-derived feeding components (data not shown). Similarly to our previous study (Trínáctý et al., 2009), isoflavones were detected in milk of control animals (C) although the daily isoflavones intake in this group was very low (3 mg/d). Thus, apparent recovery from feed to milk of daidzein was 2.5 µg/mg, of genistein was 5.0 µg/mg and of glycitein was 3.9 µg/mg in group S while apparent recoveries of individual isoflavones in C were enormously high. Similar findings were also reported by e. g. Mustonen et al. (2009), Andersen et al. (2009) or Steinshamn et al. (2008) who studied the recovery of red clover-derived phytoestrogens suggesting that the transfer rate of isoflavonoids from feed to milk is higher at low intake than at higher intake.

| Item | Units | C | S | SEM | P |
|--------------------------------|-------|--------|--------|--------|---------|
| Milk yield | kg/d | 17.6 | 19.5 | 0.50 | 0.01 |
| 4% FCM yield | kg/d | 19.0 | 20.9 | 0.68 | 0.06 |
| Daidzein | µg/L | 36.5 | 40.3 | 1.88 | 0.17 |
| Genistein | µg/L | 170.6 | 175.8 | 8.36 | 0.67 |
| Glycitein | µg/L | 23.4 | 27.9 | 0.77 | < 0.001 |
| Equol | µg/L | 3.6 | 15.6 | 1.08 | < 0.001 |
| Output | | | | | |
| Daidzein | µg/d | 643.9 | 776.9 | 33.72 | 0.01 |
| Genistein | µg/d | 3008.6 | 3396.2 | 144.37 | 0.07 |
| Glycitein | µg/d | 417.1 | 543.2 | 19.58 | < 0.001 |
| Equol | µg/d | 65.2 | 305.5 | 21.92 | < 0.001 |
| Total | µg/d | 4134.9 | 5021.8 | 173.41 | 0.001 |
| Recovery of isoflavones | | | | | |
| Recovery of daidzein | µg/mg | 670.7 | 2.5 | 26.06 | < 0.001 |
| Recovery of genistein | µg/mg | 3568.5 | 5.0 | 160.79 | < 0.001 |
| Recovery of glycitein | µg/mg | 393.5 | 3.9 | 13.00 | < 0.001 |

Table 3. Milk yield, concentration and output of isoflavones, recovery of isoflavones

3.2 Concentration of isoflavones in bovine milk and dairy products

Although the concentration of isoflavones in many vegetal species and foodstuffs of plant origin are extensively documented (e. g. Umphress et al., 2005, Nurmi et al., 2002, Liggins et al., 2000 a, b), there are only a few studies focused on the transfer of isoflavones from feed to bovine milk. The isoflavones content in milk varies depending on a variety of factors, such as the composition of the diet and the season. The concentration of equol in milk of cows fed red clover based diets can range from 14 to 643 µg/L in dependence on isoflavones intake (King et al., 1998, Antignac et al., 2004, Purup et al., 2005, Hoikkala et al., 2007, Steinshamn et al., 2008, Mustonen et al., 2009) while concentration of equol originated from dietary soybean was 55 µg/L (Trínáctý et al., 2009).

Data concerning the content of isoflavones in dairy products are scarce. However, Kuhnle et al. (2008) analysed total of 115 samples of food of animal origin and their corresponding vegetarian substitutes for phytoestrogens content including total isoflavones and equol. They reported low content of isoflavones and equol in all samples of various commercially available milk and dairy products except butter where equol was not detected. The levels of

total isoflavones determined in their study in whole and skimmed milk, cream and plain yoghurt were considerably lower than that found in our study in C, but the content of equol in mentined products was higher than in C but lower than in S.

For technological processing samples of morning milk from each group in each period were taken, immedietly after the collection, the milk was cooled to 6 °C, transported to experimental pilot plant, stored overnight at 6 - 8 °C and then processed. Isoflavones content in raw milk prior technological processing is given in Table 4.

| Isoflavones | Units | C | S |
|-------------|-------|-------|-------|
| Daidzein | µg/L | 47.6 | 45.4 |
| Genistein | µg/L | 143.8 | 147.1 |
| Glycitein | µg/L | 13.2 | 16.1 |
| Equol | µg/L | 4.1 | 25.4 |
| Total | µg/L | 208.7 | 234.0 |

Table 4. Isoflavones content in raw milk prior technological processing (µg/L of wet weight)

Concentration of daidzein, genistein and glycitein was similar in both groups. Milk from S group had higher concentration of equol (25.4 µg/L) in comparison to C group (4.1 µg/L). Resulting concentration of total isoflavones was 208.7 µg/L in C and 234.0 µg/L in S.

3.3 Effect of technological processing

The effect of skimming on the concentration of isoflavones is given in Table 5.

| | | C | | S | |
|-----------------------------|------|-----------|-------|-----------|-------|
| | | Skim milk | Cream | Skim milk | Cream |
| Concentration in wet weight | | | | | |
| Daidzein | µg/L | 43.5 | 49.4 | 50.2 | 47.7 |
| Genistein | µg/L | 157.4 | 156.5 | 148.1 | 150.1 |
| Glycitein | µg/L | 14.1 | 16.9 | 15.4 | 22.8 |
| Equol | µg/L | 4.0 | 3.3 | 27.4 | 18.1 |
| Total | µg/L | 219.0 | 226.2 | 241.0 | 238.6 |
| Concentration in dry weight | | | | | |
| Daidzein | µg/L | 444.0 | 109.0 | 525.0 | 117.0 |
| Genistein | µg/L | 1605.1 | 345.3 | 1551.2 | 368.7 |
| Glycitein | µg/L | 144.0 | 37.1 | 161.2 | 56.5 |
| Equol | µg/L | 40.7 | 7.4 | 286.2 | 44.4 |
| Total | µg/L | 2233.9 | 498.7 | 2523.6 | 586.6 |

Table 5. Effect of skimming on concentration of isoflavones

In general, it is accepted that isoflavones are not destroyed by heat treatment but rather are subject to intra-conversions between the different forms (e. g. Grun et al., 2001, Jackson et al., 2002, Uzzan et al., 2007). Losses of isoflavones determined during cooking were usually assumed to be a result of leaching into the discarded cooking water (Setchell, 1998, Frank et al., 1999, Grun et al., 2001, Hendrich & Murphy 2001, Jackson et al., 2002).

In our study pasteurisation at 65 °C for 30 min had no effect on concentrations of individual isoflavones neither in the C nor in S group (Table 6).

| | | C | | S | |
|-----------------------------|------|----------------------|----------------------|----------------------|----------------------|
| | | Prior pasteurisation | After pasteurisation | Prior pasteurisation | After pasteurisation |
| Concentration in wet weight | | | | | |
| Daidzein | µg/L | 52.9 | 50.8 | 48.2 | 47.3 |
| Genistein | µg/L | 170.4 | 169.4 | 154.9 | 156.1 |
| Glycitein | µg/L | 15.7 | 15.4 | 18.4 | 16.4 |
| Equol | µg/L | 4.4 | 4.0 | 27.9 | 26.7 |
| Total | µg/L | 243.4 | 239.6 | 249.3 | 246.5 |
| Concentration in dry weight | | | | | |
| Daidzein | µg/L | 369.0 | 385.2 | 366.0 | 362.2 |
| Genistein | µg/L | 1275.9 | 1285.3 | 1176.0 | 1194.7 |
| Glycitein | µg/L | 117.3 | 117.0 | 139.4 | 125.7 |
| Equol | µg/L | 32.7 | 30.3 | 211.8 | 204.7 |
| Total | µg/L | 1821.9 | 1817.9 | 1893.1 | 1887.3 |

Table 6. Effect of pasteurisation

Similar findings were reported by King et al. (1998) for equol and genistein in milk from red-clover based pasture although they did not report details about temperature and time. Also Uzzan & Labuza (2004) and Uzzan et al. (2007) determined no effect of thermal treatment at 72, 121, 140 and 140 °C for 120, 24, 2 and 20 sec, respectively on content of daidzein, genistein and glycitein in an isoflavone-enriched cow milk beverage.

The concentrations of isoflavones during the yoghurt manufacturing and storage are given in Table 7. There was a decline in pH during fermentation from initial 6.55 and 6.53 to 4.18 and 4.20 in C and S, respectively. The decrease in pH was consistent in both groups. To our knowledge, there is no study focused on the changes in isoflavone profile during fermentation and storage of isoflavone-enriched dairy products. However, the effect of fermentation of soybean products with various strain of bacteria and the effect of subsequent storage of fermented products has been studied in several recent studies (e. g. Tsangalis et al., 2002, Uzzan et al., 2007, Chen et al., 2010) mainly with a view to β -glucosidase activity of used bacterial strains and with a view to conversion of isoflavone glucosides to aglycones that are absorbed by humans faster and in greater amounts than the isoflavone glucoside (Izumi et al., 2000).

In the present study, concentration of total isoflavones in plain yoghurt after fermentation at 37 °C for 16 - 18 h was slightly decreased in C from 239.6 to 239.2 µg/L, while the total isoflavone concentration in S was reduced from 246.5 to 237.2 µg/L. Our findings are in agreement with e. g. Chen et al. (2010), Tsangalis et al. (2002) or King & Bignell (2000) who suggested that losses in total isoflavone concentration were caused by hydrolytic cleavage of the glucose moiety from the glucosides, which contributes to the mass of isoflavones when found as glucoside forms. Similarly, Tsangalis et al. (2002) reported that significant losses in total isoflavone concentration during fermentation of soymilks only occurred, when there were significant decreases in the concentration of isoflavone glucosides caused by enzymic hydrolysis.

During the fermentation (37 °C, 16 - 18 h), concentration of equol changed from 4.0 to 6.0 µg/L in C and from 26.7 to 26.8 µg/L in S. There are no comparable data to compare changes in equol concentration during fermentation in dairy products. However, recent findings suggest that equol can occur in fermented products as a result of fermentation by

| | | C | S |
|--|------|--------|--------|
| Concentration on a wet weight basis | | | |
| Daidzein | | | |
| Full-fat milk after pasteurisation | µg/L | 50.8 | 47.3 |
| Yoghurt after manufacturing | µg/L | 50.8 | 49.5 |
| Yoghurt after storage | µg/L | 51.3 | 48.2 |
| Genistein | | | |
| Full-fat milk after pasteurisation | µg/L | 169.4 | 156.1 |
| Yoghurt after manufacturing | µg/L | 167.6 | 145.1 |
| Yoghurt after storage | µg/L | 165.8 | 147.6 |
| Glycitein | | | |
| Full-fat milk after pasteurisation | µg/L | 15.4 | 16.4 |
| Yoghurt after manufacturing | µg/L | 14.8 | 15.8 |
| Yoghurt after storage | µg/L | 13.6 | 14.8 |
| Equol | | | |
| Full-fat milk after pasteurisation | µg/L | 4.0 | 26.7 |
| Yoghurt after manufacturing | µg/L | 6.0 | 26.8 |
| Yoghurt after storage | µg/L | 5.7 | 20.5 |
| Total isoflavones | | | |
| Full-fat milk after pasteurisation | µg/L | 239.6 | 246.5 |
| Yoghurt after manufacturing | µg/L | 239.2 | 237.2 |
| Yoghurt after storage | µg/L | 236.3 | 231.1 |
| Concentration on a dry weight basis | | | |
| Daidzein | | | |
| Full-fat milk after pasteurisation | µg/L | 385.2 | 362.2 |
| Yoghurt after manufacturing | µg/L | 393.9 | 391.1 |
| Yoghurt after storage | µg/L | 399.2 | 381.8 |
| Genistein | | | |
| Full-fat milk after pasteurisation | µg/L | 1285.3 | 1194.7 |
| Yoghurt after manufacturing | µg/L | 1298.9 | 1145.8 |
| Yoghurt after storage | µg/L | 1290.4 | 1167.9 |
| Glycitein | | | |
| Full-fat milk after pasteurisation | µg/L | 117.0 | 125.7 |
| Yoghurt after manufacturing | µg/L | 114.9 | 124.7 |
| Yoghurt after storage | µg/L | 105.5 | 117.2 |
| Equol | | | |
| Full-fat milk after pasteurisation | µg/L | 30.3 | 204.7 |
| Yoghurt after manufacturing | µg/L | 46.4 | 211.2 |
| Yoghurt after storage | µg/L | 44.5 | 162.0 |
| Total isoflavones | | | |
| Full-fat milk after pasteurisation | µg/L | 1817.9 | 1887.3 |
| Yoghurt after manufacturing | µg/L | 1854.1 | 1872.8 |
| Yoghurt after storage | µg/L | 1839.6 | 1828.9 |

Table 7. Effect of yoghurt manufacturing and storage

certain bacterial strains. E.g. Tsangalis et al. (2002) found equol in soymilk fermented with *Bifidobacterium pseudolongum*, *Bifidobacterium longum-a* and *Bifidobacterium animalis*. In the present study, yoghurt cultures probably contributed to elevated levels of equol by transformation of daidzein to equol.

After a one-month storage concentration of total isoflavones in plain yoghurt declined in both groups. Similar results were reported by Otieno et al. (2006) for soymilk fermented by *Bifidobacterium animalis* and stored at 4°C for up to 8 weeks. Based on their findings, this decline is probably caused by the glucosides that were not stable during storage and incurred more losses in comparison to aglycone forms.

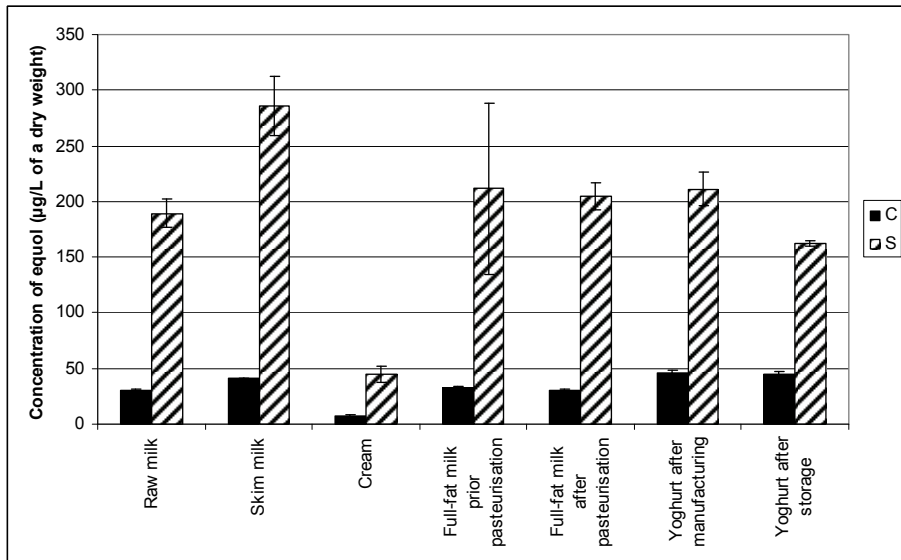

Fig. 1. Changes in equol content ($\mu\text{g/L}$ of dry weight, mean \pm standard deviation) during technological processing

After one-month storage the equol content decreased to 44.5 $\mu\text{g/L}$ (dry weight) in C and to 162.0 $\mu\text{g/L}$ (dry weight) in S. There is no comparable study focused on changes in equol concentration during storage of equol enriched products. However, Otieno et al. (2006) detected equol in trace amounts in soymilk fermented with *Bifidobacterium animalis* during storage and noted that equol was not detected until the third week of storage at -80 °C, fifth week at 4 °C, while it took only 2 weeks to be detected during storage at 24.8 °C and 37 °C.

Bovine milk can be considered as a potential source of equol in human nutrition (Mustonen et al., 2009). Figure 1 summarises the changes in equol concentration expressed on a dry weight basis during various steps of technological processing determined in our study. As already mentioned, low concentrations of equol have been found in cream and relatively high concentrations in skimmed milk. From the previous discussion, it seems that the equol concentration is not altered by pasteurisation. Slight increase in equol concentration was noted during fermentation by yoghurt cultures consisting of *Streptococcus thermophilus* and *Lactobacillus delbrueckii subsp. bulgaricus*. Losses during one-month storage of plain yoghurt reached for 23 % in S while in C were negligible.

4. Conclusion

It has been proved that bovine milk can be a potential source of equol for human especially for so called non-equol producers as an alternative strategy for obtaining the health-promoting benefits of equol. Besides red clover, soybean-derived feeding components can be also a potential source of isoflavones in bovine milk. Data suggest that the concentration of equol in milk can be manipulated by choosing an appropriate form of technologically processed soybeans. To our knowledge, this is the first study monitoring the changes in isoflavones concentrations in bovine milk during technological processing. Results of the present work show that studied dairy products, it is pasteurised milk, skim milk and yoghurt can be also included among possible sources of equol in human nutrition. Low concentrations of isoflavones (on a dry matter basis) were also detected in cream. After one-month storage, decrease in equol concentration was noted in isoflavones enriched yoghurt. Further study is needed to determine kinetics of isoflavone degradation during fermentation and storage of dairy products. With regards to differences in bioavailability of various forms of isoflavones (glucosides, aglycones, malonyl- and acetyl-forms) for human, further studies focused on possible intra-conversions between the different forms would be also useful.

5. Acknowledgements

This study was supported by the Ministry of Education, Youth and Sports, Czech Republic, projects No. 2B08073, MSM 2678846201, MSM 6046137305 and within specific university research MSMT No. 21/2010.

6. References

- Adlercreutz, H.; Fotsis, T.; Bannwart, C.; Wähälä, K.; Makela, T.; Brunow, G. & Hase, T. (1986). Determination of urinary lignans and phytoestrogen metabolites, potential antiestrogens and anticarcinogens, in urine of women on various habitual diets. *Journal of Steroid Biochemistry and Molecular Biology*, 25, 791-797, ISSN: 0960-0760
- Andersen, C.; Weisbjerg, M. R.; Hansen-Møller, J. & Sejrsen, K. (2009). Effect of forage on the content of phyto-oestrogens in bovine milk. *Animal*, 3, 617-622, ISSN: 1751-7311
- Antignac, J. P.; Cariou, R.; Le Bizec, B. & Andre, F. (2004). New data regarding phytoestrogens content in bovine milk. *Food Chemistry*, 87, 275-281, ISSN: 0308-8146
- Arora, A.; Nair, M. G. & Strasburg, G. M. (1998). Antioxidant activities of isoflavones and their biological metabolites in a liposomal system. *Archives of Biochemistry and Biophysics*, 356, 133-141, ISSN: 0003-9861
- Atkinson, C.; Berman, S.; Humbert, O. & Lampe, J. W. (2004). In vitro incubation of human feces with daidzein and antibiotics suggests interindividual differences in the bacteria responsible for equol production. *Journal of Nutrition*, 134, 596-599, ISSN: 0022-3166
- Atkinson, C.; Frankenfeld, C. L. & Lampe, J. W. (2005). Gut bacterial metabolism of the soy isoflavone daidzein: exploring the relevance to human health. *Experimental Biology and Medicine*, 230, 155-170, ISSN: 1535-3702
- Blair, R. M.; Appt, S. E.; Franke, A. A. & Clarkson, T. B. (2003). Treatment with antibiotics reduces plasma equol concentration in Cynomolgus monkeys (*Macaca fascicularis*). *Journal of Nutrition*, 133, 2262-2267, ISSN: 0022-3166

- Bowey, E.; Adlercreutz, H. & Rowland, I. R. (2003). Metabolism of isoflavones and lignans by the gut microflora: a study in germ-free and human flora associated rats. *Food and Chemical Toxicology*, 41, 631-636, ISSN: 0278-6915
- Chen, T. R.; Su, R. Q. & Wei, Q. K. (2010). Hydrolysis of isoflavone phytoestrogens in soymilk fermented by *Lactobacillus* and *Bifidobacterium* cocultures. *Journal of Food Biochemistry*, 34, 1-12, ISSN: 0145-8884
- Chouinard, P. Y.; Le' Vesque, J.; Girard, V. & Brisson, G. J. (1997). Dietary soybeans extruded at different temperatures: milk composition and in situ fatty acid reactions. *Journal of Dairy Science*, 80, 2913-2924, ISSN: 0022-0302
- Coldham, N. G.; Howells, L. C.; Santi, A.; Montesissa, C.; Langlais, C.; King, L. J.; MacPherson, D. D. & Sauer, M. J. (1999). Biotransformation of genistein in the rat: elucidation of metabolite structure by production mass fragmentology. *Journal of Steroid Biochemistry and Molecular Biology*, 70, 169-184, ISSN: 0960-0760
- Dakora, F. D. & Phillips, D. A. (1996). Diverse functions of isoflavonoids in legumes transcend anti-microbial definitions of phytoalexins. *Physiological and Molecular Plant Pathology*, 49, 1-20, ISSN: 0885-5765
- Eldridge, A. C. & Kwolek, W. F. (1983). Soybean isoflavones: effect of environment and variety on composition. *Journal of Agricultural and Food Chemistry*, 31, 394-396, ISSN: 0021-8561
- Frank, A. A.; Hankin, J. H.; Yu, M. C.; Maskarinec, G.; Low, S. H. & Custer, L. J. (1999). Isoflavone level in soy foods consumed by multiethnic populations in Singapore and Hawaii. *Journal of Agricultural and Food Chemistry*, 47, 977-986, ISSN: 0021-8561
- Franke, A. A.; Custer, L. J.; Wang, W. & Shi, C. Y. (1998). HPLC analysis of isoflavonoids and other phenolic agents from foods and from human fluids. *Proceedings of the Society for Experimental Biology and Medicine*, 217, 263-273, ISSN: 0037-9727
- Grun, I. U.; Adhikari, K.; Li, C.; Li, Y.; Lin, B.; Zhang, J. & Fernando, L. N. (2001). Changes in the profile of genistein, daidzein, and their conjugates during thermal processing of tofu. *Journal of Agricultural and Food Chemistry*, 49, 2839-2843, ISSN: 0021-8561
- Heinonen, S.; Wähälä, K. & Adlercreutz, H. (1999). Identification of isoflavone metabolites dihydrodaidzein, dihydrogenistein, 6'-OH-O-dma, and cis-4-OH-equol in human urine by gas chromatography-mass spectroscopy using authentic reference compounds. *Analytical Biochemistry*, 274, 211-217, ISSN: 0003-2697
- Heinonen, S.; Hoikkala, A.; Wähälä, K. & Adlercreutz, H. (2003). Metabolism of the soy isoflavones daidzein, genistein and glycitein in human subjects. Identification of new metabolites having an intact isoflavonoid skeleton. *Journal of Steroid Biochemistry and Molecular Biology*, 87, 285-299, ISSN: 0960-0760
- Hendrich, S. & Murphy, P. A. (2001). Isoflavones: source and metabolism. In: *Handbook of nutraceuticals and functional foods*. Wildman R. E. C. (Ed.), 55-75, CRC Press, ISBN: 0849387345, Boca Raton, Fla
- Hoey, L.; Rowland, I. R.; Lloyd, A. S.; Clarke, D. B. & Wiseman, H. (2004). Influence of soya-based infant formula consumption on isoflavone and gut microflora metabolite concentrations in urine and on faecal microflora composition and metabolic activity in infants and children. *British Journal of Nutrition*, 91, 607-616, ISSN: 0007-1145
- Hoikkala, A.; Mustonen, E.; Saastmoinen, I.; Jokela, T.; Teponen, J.; Saloniemi, H. & Wähälä, K. (2007). High levels of equol in skimmed Finnish cow milk. *Molecular Nutrition & Food Research* 51, 782-786, ISSN: 1613-4125

- Holman, P. (2001). Evidence for health benefits of plant phenols: local or systemic effects? *Journal of the Science of Food and Agriculture*, 81, 842–852, ISSN: 0022-5142
- Hur, H. G.; Lay, J. O. J.; Beger, R. D.; Freeman, J. P. & Rafii, F. (2000). Isolation of human intestinal bacteria metabolizing the natural isoflavone glycosides daidzin and genistin. *Archives of Microbiology*, 174, 422–428, ISSN: 0302-8933
- Izumi, T.; Piskula, M. K.; Osawa, S.; Obata, A.; Tobe, K.; Saito, M.; Kataoka, S.; Kubota, A. Y. & Kikuchi, M. (2000). Soy isoflavone aglycones are absorbed faster and in higher amounts than their glucosides in humans. *Journal of Nutrition*, 130, 1695–1699, ISSN: 0022-3166
- Jackson, C. J. C.; Dini, J. P.; Lavandier, C.; Rupasinghe, H. P. V.; Faulkner, H.; Poysa, V.; Buzzell, D. & DeGrandis, S. (2002). Effects of processing on the content and composition of isoflavones during the manufacturing of soy beverage and tofu. *Process Biochemistry*, 37, 1117–1123, ISSN: 1359-5113
- Joannou, G. E.; Kelly, G. E.; Reeder, A. Y.; Waring, M. & Nelson, C. (1995). A urinary profile study of dietary phytoestrogens: The identification and mode of metabolism of new isoflavonoids. *Journal of Steroid Biochemistry and Molecular Biology*, 54, 167–184, ISSN: 0960-0760
- King, R. A.; Mano, M. M. & Head, R. J. (1998). Assessment of isoflavonoid concentrations in Australian bovine milk samples. *Journal of Dairy Research*, 65, 479–489, ISSN: 0022-0299
- King, R. A. & Bignell, C. M. (2000). Concentrations of isoflavone phytoestrogens and their glucosides in Australian soya beans and soya foods. *Australian Journal of Nutrition and Dietetics*, 57, 70–78, ISSN: 1032-1322
- Komprda, T.; Dvořák, R.; Suchý, P.; Fialová, M. & Šustová, K. (2000). Effect of heat treated rapeseed cakes in dairy cow diet on yield, composition and fatty acid pattern of milk. *Czech Journal of Animal Science*, 45, 325–332, ISSN: 1212-1819
- Kostelac, D.; Rechkemmer, G. & Briviba, K. (2003). Phytoestrogens modulate binding response of estrogen receptors alpha and beta to the estrogen response element. *Journal of Agricultural and Food Chemistry*, 51, 7632-7635, ISSN: 0021-8561
- Kudrna, V. & Marounek, M. (2006). Feeding oilseed products to dairy cows. *Journal of Animal and Feed Sciences*, 15, 36–69, ISSN: 1230-1388
- Kuhnle, G. G. C.; Delcaqulla, C.; Aspinall, S. M.; Runswick, S. A.; Mulligan, A. A. & Bingham, S. A. (2008). Phytoestrogen content of foods of animal origin: dairy products, eggs, meat, fish, and seafood. *Journal of Agricultural and Food Chemistry*, 56, 21, 10099-10104, ISSN: 0021-8561
- Kurzer, M. S. & Xu, X. (1997). Dietary phytoestrogens. *Annual Review of Nutrition*, 17, 353–381, ISSN: 0199-9885
- Lampe, J. W.; Karr, S. C.; Hutchins, A. M. & Slavin, J. L. (1998). Urinary equol excretion with a soy challenge: influence of habitual diet. *Proceedings of the Society for Experimental Biology and Medicine*, 217, 335–339, ISSN: 0037-9727
- Liggins, J.; Bluck, L. J. C.; Runswick, S.; Atkinson, C.; Coward, W. A. & Bingham, S. A. (2000a). Daidzein and genistein contents of vegetables. *British Journal of Nutrition*, 84, 717-725, ISSN: 0007-1145
- Liggins, J.; Bluck, L. J. C.; Runswick, S.; Atkinson, C.; Coward, W. A. & Bingham, S. A. (2000b). Daidzein and genistein content of fruits and nuts. *Journal of Nutritional Biochemistry*, 11, 326-331, ISSN: 0955-2863

- Lund, T. D.; Munson, D. J.; Haldy, M. E.; Setchell, K. D. R.; Lephart, E. D. & Handa, R. J. (2004). Equol is a novel anti-androgen that inhibits prostate growth and hormone feedback. *Biology of Reproduction*, 70, 1188-95, ISSN: 0006-3363
- Mitchell, J. H.; Gardner, P. T.; McPhail, D. B.; Morrice, P. C.; Collins, A. R. & Duthie, G. G. (1998). Antioxidant efficacy of phytoestrogens in chemical and biological model systems. *Archives of Biochemistry and Biophysics*, 360, 142-148, ISSN: 0003-9861
- Morito, K.; Hirose, T.; Kinjo, J.; Hirakawa, T.; Okawa, M.; Nohara, T.; Ogawa, S.; Inoue, S.; Muramatsu, M. & Masamune, Y. (2001). Interaction of phytoestrogens with estrogen receptors α and β . *Biological & Pharmaceutical Bulletin*, 24, 351-356, ISSN: 0918-6158
- Mustonen, E. A.; Tuori, M.; Saastamoinen, I.; Taponen, J.; Wähälä, K.; Saloniemi, H. & Vanhatalo, A. (2009). Equol in milk of dairy cows is derived from forage legumes such as red clover. *British Journal of Nutrition*, 102, 1552-1556, ISSN: 0007-1145
- Muthyala, R. S.; Ju, J.-H.; Sheng, S.; Williams, L. D.; Doerge, D. R.; Katzenellenbogen, B. S.; Helferich, W. G. & Katzenellenbogen, J. A. (2004). Equol, a natural estrogenic metabolite from soy isoflavones: convenient preparation and resolution of R- and S-equols and their differing binding and biological activity through estrogen receptors α and β . *Bioorganic & Medicinal Chemistry*, 12, 1559-1567, ISSN: 0968-0896
- Nagel, S. C.; vom Saal, F. S. & Welshons, W. V. (1999). Developmental effects of estrogenic chemicals are predicted by an in vitro assay incorporating modification of cell uptake by serum. *Journal of Steroid Biochemistry and Molecular Biology*, 69, 343-357, ISSN: 0960-0760
- Nurmi, T.; Mazur, W.; Heinonen, S.; Kokkonen, J. & Adlercreutz, H. (2002). Isoflavone content of the soy based supplements. *Journal of Pharmaceutical and Biomedical Analysis*, 28, 1-11, ISSN: 0731-7085
- Otieno, D. O.; Ashton, J. F. & Shah, N. P. (2006). Stability of isoflavone phytoestrogens in fermented soymilk with *Bifidobacterium animalis* Bb12 during storage at different temperatures. *International Journal of Food Science and Technology*, 41, 1182-1191, ISSN: 0950-5423
- Prabhakaran, M. P. & Perera, C. O. (2006). Effect of extraction methods and UHT treatment conditions on the level of isoflavones during soymilk manufacture. *Food Chemistry*, 99, 231-237, ISSN: 0308-8146
- Purup, S.; Hansen-Møller, J.; Sejrsen, K.; Christensen, L. P.; Lykkesfeldt, A. E.; Leffers, H. & Skakkebak, N. E. (2005). Increased phytoestrogen content in organic milk and the biological importance. Newsletter from Danish Research Centre for Organic Farming, no. 2. Danish Research Centre for Organic Farming, Tjele, Denmark.
- Rimbach, G.; De Pascual-Teresa, S.; Ewins, B. A.; Matsugo, S.; Uchida, Y.; Minihane, A. M.; Turner, R.; VafeiAdou, K. & Weinberg, P. D. (2003). Antioxidant and free radical scavenging activity of isoflavone metabolites. *Xenobiotica*, 33, 913-925, ISSN: 0049-8254
- Rowland, I.; Wiseman, H. & Sanders, T. (1999). Metabolism of oestrogens and phytoestrogens: role of the gut microflora. *Biochemical Society Transactions*, 27, 304-308, ISSN: 0300-5127
- Rowland, I. R.; Wiseman, H.; Sanders, T. A.; Adlercreutz, H. & Bowey, E. A. (2000). Interindividual variation in metabolism of soy isoflavones and lignans: influence of

- habitual diet on equol production by the gut microflora. *Nutrition and Cancer*, 36, 27–32, ISSN: 0163-5581
- Sathyamoorthy, N. & Wang, T. T. Y. (1997). Differential effects of dietary phyto-oestrogens daidzein and equol on human breast cancer MCF-7 cells. *European Journal of Cancer*, 33, 2384–2389, ISSN: 0959-8049
- Schmitt, E.; Dekant, W. & Stopper, H. (2001). Assaying the estrogenicity of phytoestrogens in cells of different estrogen sensitive tissues. *Toxicology In Vitro*, 15, 433-439, ISSN: 0887-2333
- Setchell, K. D. R.; Brown, N. M. & Lydeking-Olsen, E. (2002). The clinical importance of the metabolite equol - a clue to the effectiveness of soy and its isoflavones. *Journal of Nutrition*, 132, 3577-3584, ISSN: 0022-3166
- Setchell, K. D. R. (1998). Phytoestrogens: biochemistry, physiology, and implications for human health of soy isoflavones. *American Journal of Clinical Nutrition*, 68, 1333S–1346S, ISSN: 0002-9165
- Simons, A. L.; Renouf, M.; Hendrich, S. & Murphy, P. A. (2005). Metabolism of glycitein (7,4'-dihydroxy-6-methoxy-isoflavone) by human gut microflora. *Journal of Agricultural and Food Chemistry*, 53, 8519–8525, ISSN: 0021-8561
- Steer, T. E.; Johnson, I. T.; Gee, J. M. & Gibson, G. R. (2003). Metabolism of the soyabean isoflavone glycoside genistin in vitro by human gut bacteria and the effects of prebiotics. *British Journal of Nutrition*, 90, 635-642, ISSN: 0007-1145
- Steinshamn, H.; Purup, S.; Thuen, E. & Hansen-Møller, J. (2008). Effects of clover-grass silages and concentrate supplementation on the content of phytoestrogens in dairy cow milk. *Journal of Dairy Science*, 91, 2715–2725, ISSN: 0022-0302
- Třináctý, J.; Křížová, L.; Schulzová, V.; Hajšlová, J. & Hanuš, O. (2009). The effect of feeding soybean-derived phytoestrogens on their concentration in plasma and milk of lactating dairy cows. *Archives of Animal Nutrition*, 63, 1-11, ISSN: 1745-039X
- Tsangalis, D.; Ashton, J. F.; McGill, A. E. J. & Shah, N. P. (2002). Enzymic transformation of isoflavone phytoestrogens in soymilk by β -glucosidase-producing *Bifidobacteria*. *Journal of Food Science*, 67, 3104–3113, ISSN: 0022-1147
- Turner, R.; Baron, T.; Wolffram, S.; Minihane, A. M.; Cassidy, A.; Rimbach, G. & Weinberg, P. D. (2004). Effect of circulating forms of soy isoflavones on the oxidation of low density lipoprotein. *Free Radical Research*, 38, 209-216, ISSN: 1071-5762
- Umphress, S. T.; Murphy, S. P.; Franke, A. A.; Custer, L. J. & Blitz, C. L. (2005). Isoflavone content of foods with soy additives *Journal of Food Composition and Analysis*, 18, 533-550, ISSN: 0889-1575
- Uzzan, M. & Labuza, T. P. (2004). Critical issues in R&D of soy isoflavone–enriched foods and dietary supplements. *Journal of Food Science*, 69, R77–R86, ISSN: 0022-1147
- Uzzan M.; Nechrebeki, J. & Labuza T. P. (2007). Thermal and storage stability of nutraceuticals in a milk beverage dietary supplement. *Journal of Food Science*, 72, E109-E114, ISSN: 0022-1147
- Wähälä, K.; Salakka, A. & Adlercreutz, H. (1998). Synthesis of novel mammalian metabolites of the isoflavonoid phytoestrogens daidzein and genistein. *Proceedings of the Society for Experimental Biology and Medicine*, 217, 293-299, ISSN: 0037-9727
- Walsh, K. R. & Failla, M. L. (2009). Transport and metabolism of equol by Caco-2 human intestinal cells. *Journal of Agricultural and Food Chemistry*, 57, 8297–8302, ISSN: 0021-8561

- Walsh, K. R.; Zhang, Y. C.; Vodovotz, Y.; Schwartz, S. J. & Failla, M. L. (2003). Stability and bioaccessibility of isoflavones from soy bread during in vitro digestion. *Journal of Agricultural and Food Chemistry*, 51, 4603–4609, ISSN: 0021-8561
- Wang, H. J. & Murphy, P. A. (1994). Isoflavone composition of American and Japanese soybeans in Iowa: effects of variety, crop year, and location. *Journal of Agricultural and Food Chemistry*, 42, 1674–1677, ISSN: 0021-8561
- Zheng, Y.; Hu, J.; Murphy, P. A.; Alekel, D. L.; Franke, W. D. & Hendrich, S. (2003). Rapid gut transit time and slow fecal isoflavone disappearance phenotype are associated with greater genistein bioavailability in women. *Journal of Nutrition*, 133, 3110–3116, ISSN: 0022-3166

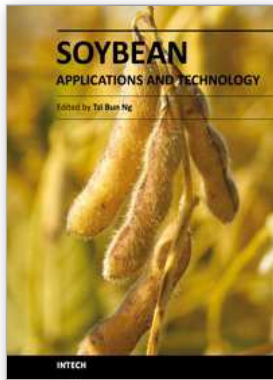

Soybean - Applications and Technology

Edited by Prof. Tzi-Bun Ng

ISBN 978-953-307-207-4

Hard cover, 402 pages

Publisher InTech

Published online 26, April, 2011

Published in print edition April, 2011

Soybean is an agricultural crop of tremendous economic importance. Soybean and food items derived from it form dietary components of numerous people, especially those living in the Orient. The health benefits of soybean have attracted the attention of nutritionists as well as common people.

How to reference

In order to correctly reference this scholarly work, feel free to copy and paste the following:

Ludmila Křížová, Jiří Třináctý, Jana Hajšlová and Šárka Havlíková (2011). The Effect of Technological Processing on the Content of Isoflavones in Bovine Milk and Dairy Products, *Soybean - Applications and Technology*, Prof. Tzi-Bun Ng (Ed.), ISBN: 978-953-307-207-4, InTech, Available from: <http://www.intechopen.com/books/soybean-applications-and-technology/the-effect-of-technological-processing-on-the-content-of-isoflavones-in-bovine-milk-and-dairy-product>

INTECH

open science | open minds

InTech Europe

University Campus STeP Ri
Slavka Krautzeka 83/A
51000 Rijeka, Croatia
Phone: +385 (51) 770 447
Fax: +385 (51) 686 166
www.intechopen.com

InTech China

Unit 405, Office Block, Hotel Equatorial Shanghai
No.65, Yan An Road (West), Shanghai, 200040, China
中国上海市延安西路65号上海国际贵都大饭店办公楼405单元
Phone: +86-21-62489820
Fax: +86-21-62489821

© 2011 The Author(s). Licensee IntechOpen. This chapter is distributed under the terms of the [Creative Commons Attribution-NonCommercial-ShareAlike-3.0 License](#), which permits use, distribution and reproduction for non-commercial purposes, provided the original is properly cited and derivative works building on this content are distributed under the same license.

Productive Efficiency of Soybean Production in the Mekong River Delta of Vietnam

Huynh Viet Khai and Mitsuyasu Yabe
Kyushu University
Japan

1. Introduction

Vietnam was an agricultural importing country during the 1970s. Since reforming its policies in 1986, through the removal of price controls on many goods, decollectivization of land, reduction or removal trade barriers and opening up to foreign direct investment, Vietnam has gradually become one of the biggest agricultural exporting countries in the world. Recently, it has been the world's leading exporter of cashews, coffee, rubber, and black pepper, and the second biggest rice exporter. Almost all Vietnamese export rice originates from the Mekong River Delta (MRD), an area of around 40,000 km². More than 18 million tons of rice are produced in the MRD every year, and this comprises half of the total amount of rice produced in Vietnam. In addition, MRD farmers also grow vegetable crops like cassava and maize in paddy fields between two planting seasons of rice to gain extra income and improve soil fertility. Soybeans are one of the most popular vegetable crops in the MRD. This study used primary data on soybean farmers for analyzing productive efficiency in the MRD of Vietnam.

Although agriculture plays the most important role in the Vietnamese economy, its contribution to GDP is gradually decreasing every year. The slow rate of agriculture development results in low income, which seriously limits opportunities for savings and investment in rural households. Consequently, the rate of development of nonagricultural sectors is also declining, resulting in a lack of jobs and more serious poverty in rural areas. Some reports have found that low efficiency in agricultural production could damage the environment through deforestation or water pollution (Tewodros, 2001).

Most studies agree that economic development strategy for the agricultural sector should be based on the promotion of increasing yields or production amounts, especially for small-scale farmers. Some empirical evidence shows that small-scale farms not only provided jobs to reduce unemployment but also distributed income as well as commodity demand in other economic sectors (Bravo-Ureta & Evenson, 1994). For this reason, researchers and policymakers have paid much attention to the adaptation of new technologies to increase the productivity and income of households. However, in recent decades, the development of technologies in agricultural sectors is already high. This suggests that the increase in productivity originally from the more efficient use of available technologies is vindicated (Bravo-Ureta & Pinheiro, 1997).

The term "productive efficiency", as used in this study, refers to the amount of possible output gain without any additional inputs or new technologies. The measurement of

efficiency is to determine output gain because this improves the performance of agricultural production with available technologies. A policy mainly focusing on more efficiency in production is considered as using more efficient inputs, increasing outputs and then improving income. In the short-term, improvement in agricultural production with pre-existing technologies is better than the implementation of new technologies (Belbase & Grabowski, 1985; Shapiro, 1977).

The main objective of this study is to measure the possibilities of productivity gains from enhancing the efficiency of soybean farmers in the MRD of Vietnam. The analytical method of the study is to measure the productive efficiency of soybean farmers in the MRD by applying a stochastic frontier and to identify some determinants of productive efficiency. The first step is to estimate farm-level technical efficiency (TE), allocative efficiency (AE) and economic efficiency (EE). The second step of analysis is to calculate separated Tobit equations with the dependent variables TE, AE and EE and the independent variables of the important factors related to soybean production and social characteristics of the farmers. The study aims to provide policy makers and concerned people with more information on the present situation of agriculture and agricultural policies in Vietnam by not only estimating the efficiency score for soybean cultivation, but also determining some factors that have impact on this efficiency score.

2. Productive efficiency

Production efficiency is composed of two factors. The purely technical, or physical, component is defined as the producer's ability to avoid waste during production. In other words, producers use the given inputs to create an output as high as possible, or produce a given output by applying inputs as low as possible. Thus, the target of an estimate of technical efficiency is to find solutions to increase output or decrease input in the context of available technologies. The allocative, or price component is determined by the combination of inputs and outputs in the optimum level in terms of considering market prices (Lovell, 1993). Measuring technical efficiency means to use input and output quantity without introducing their prices. Technical efficiency can be further deconstructed into three components, which are scale efficiency (the potential productivity gain from achieving the optimal size of a firm), congestion (increase in some inputs could decrease output) and pure technical efficiency (Farrell, 1957).

Economic efficiency involves increasing output without using more than conventional inputs. The use of existing technologies is more cost-effective than applying new technologies if farmers currently cultivate their products with the existing technology inefficiently (Belbase & Grabowski, 1985; Shapiro, 1977). Economic efficiency can be classified into two categories: technical efficiency and allocative efficiency. Technical efficiency measures the ability of a farmer to achieve maximum output with given and obtainable technology, while allocative efficiency tries to capture a farmer's ability to apply the inputs in optimal proportions with respective prices (Farrell, 1957; Shapiro, 1977; Tim *et al.*, 2005).

In Fig. 1, it is assumed that a firm uses two inputs (X_1 and X_2) to produce a single output (Q) under the assumption of constant returns to scale. The SS' curve represents the isoquant of fully efficient firms, and could be used to measure technical efficiency. If a given firm uses quantities of inputs at point A to produce a unit of output, the technical inefficiency of that firm could be represented as the distance AB . It is the amount by which the level of input

needed could be proportionally reduced without a decline in output. This is usually expressed in percentage terms by the ratio BA/OA , which represents the percentage by which all inputs need to be reduced to achieve technically efficient production. The technical efficiency (TE) of a firm ranges between 0 and 1, and is most commonly measured by the ratio

$$TE = OB/OA \quad (1)$$

If TE is equal to 1, the firm produces with full technical efficiency. For example, at point B firm could gain full technical efficiency because point B lies in the efficient isoquant curve.

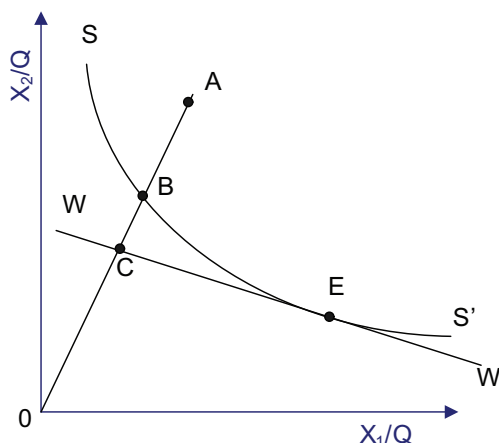

Fig. 1. Technical, allocative and economic efficiency

If the input price ratio, represented by the slope of the isocost line WW' , is also known, allocative efficiency (AE) at A can be calculated and identified by the ratio:

$$AE = OC/OB \quad (2)$$

A decrease in production costs with the distance from B to C would happen if production was performed at the allocatively and technically efficient point E instead of at the technically efficient, but allocatively inefficient point B .

The total economic efficiency (EE) is defined to be the ratio

$$EE = OC/OA \quad (3)$$

The distance from A to C also represents the cost reduction in production if a firm produces at point C with technical and allocative efficiency, instead of at point A with technical and allocative inefficiency. Economic efficiency is a combination of technical and allocative efficiency.

3. Techniques of efficiency measurement

There are two methods widely used in the literature to estimate technical efficiency of agricultural production. They are data envelopment analysis (DEA) and stochastic frontier analysis (Coelli, 2005).

DEA, which is a mathematical programming method, is useful for multiple-input and multiple-output production technologies. This method of analysis, initially studied by Charnes, Cooper and Rhodes (1978), uses linear programming methods to build a non-parametric piece-wise surface (or frontier) over the data and estimate each data point's efficiency relative to the frontier (Coelli, 2005). The DEA method assumes that the variables are reasonably separated into inputs and outputs. Each data point in DEA represents a decision making unit, or a producer in practice. The "decision" of a unit is to create outputs by using inputs as efficiently as possible (Zhiqiang *et al.*, 2004).

Stochastic frontier analysis uses econometrics based on the deterministic parameter frontier of Aigner and Chu (1968). The random noise around the estimated production frontier is recognized in the stochastic frontier analysis. For instance, using multiple inputs to predict one single output is based on the functional relationship $y_i = f(x_i, \beta) + \varepsilon_i$, where i indicates the number of the identified observations and β is the estimated parameters. The ε_i error term is formulated by a random error v_i and the technical inefficiency u_i . Stochastic frontier analysis will be decreased to the deterministic frontier analysis assuming v_i equals 0, and the central tendency analysis if u_i is equal to 0.

The different techniques are applied to generate the strengths and weaknesses of the two methods. The econometric approach is stochastic and parametric. It has the ability to separate the effects of noise from the effects of inefficiency and confound the effects of misspecification of functional form (of both technology and inefficiency) with inefficiency, but generates good results only for single output and multiple inputs. On the contrary, the mathematical programming approach is not stochastic and not parametric. It cannot separate the effects of noise and inefficiency during the calculation of technical efficiency, and less sensitive to the type of specification error (Tewodros, 2001), but could be useful to apply to farms with multiple-inputs and multiple-outputs production.

Since soybean production in the MRD is an example of single output and multiple-output production, this study focuses on the use of an econometric approach for measuring technical efficiency based on the production frontier model.

4. The econometric approach to efficiency measurement

The calculation of technical efficiency using the production frontier model is only applied to single output production (Possibly also to multiple-output production if the multiple-outputs are aggregated into a single-output index). Depending on the structure of the data (cross-sectional or panel data), different estimates are applied. In this study, we assume that we have cross-sectional data on N farmers with the use of K inputs and generation of a single output. A production frontier model can be written as

$$y_i = f(x_i; \beta) \times TE_i, \quad (4)$$

where y_i represents the possible production level of the i^{th} producer ($i = 1, \dots, N$), $f(x_i; \beta)$ is the production frontier of the vector x_i of K inputs used by producer i and a vector β of unknown parameters, and TE_i is the output-oriented technical efficiency of producer i .

We could transform equation (4) into the following equation:

$$TE_i = \frac{y_i}{f(x_i; \beta)}, \quad (5)$$

Technical efficiency is defined as the ratio of observed output (y_i) and maximum feasible output ($f(x_i; \beta)$) with current available technologies. TE is equal to 1 if y_i is the same as the maximum output $f(x_i; \beta)$. Technical inefficiency exists if the observed value is below the estimated frontier or TE is less than 1.

According to the assumption of statistical noise and the definition of inefficiency, a production frontier model of cross-sectional data is estimated by the deterministic frontier and stochastic frontier models. Because y_i is bordered above by the deterministic quantity, $f(x_i; \beta)$, the model (5) is defined as a deterministic frontier production function. The technical efficiency of a given producer is estimated by the difference between the frontier output $f(x_i; \beta)$ and the level of production for the producer y_i (Battese, 1992).

The measurement of technical inefficiency associated with the deterministic frontier model is larger and not reasonable because it includes out-of-control factors like disasters, diseases, and market uncertainties. Therefore, almost all current studies have applied the stochastic production frontier model, also including producer-specific random shock to estimate the technical efficiency of a given producer. The model is performed by the following equation:

$$y_i = f(x_i; \beta) \times \exp(v_i) \times TE_i \quad (6)$$

where v_i is a random zero-mean error in terms of specific random shocks (e.g., disasters, diseases, market uncertainties) that are out of the farm's control. Because the stochastic quantity, $[f(x_i; \beta) \times \exp(v_i)]$, lies above the possible output, the model (6) is identified as a stochastic frontier. Technical efficiency of an individual farmer is determined by the following equation:

$$TE_i = \frac{y_i}{f(x_i; \beta) \times \exp(v_i)}, \quad (7)$$

The estimate of technical efficiency by the stochastic frontier model is also defined by the ratio of observed output to the corresponding frontier output (y_i) over the maximum feasible output ($f(x_i; \beta)$) and random out-of-control factors. Thus, TE is equal to 1 if y_i is the same as the maximum output of $f(x_i; \beta) \times \exp(v_i)$.

The stochastic production frontier model originally introduced by Aigner, Lovell, and Schmidt (1977), Battese and Corra (1977), and Meeusen and Van (1977) allows separating inefficient effects and random errors not under control of the farmer such as weather, luck, and market uncertainties, in the calculation of technical efficiency. Thus, the stochastic production frontier model is applied in this study in the hope of obtaining a more reasonable and correct technical efficiency estimate than the deterministic frontier model.

5. Analytical framework

In the calculation of the productive efficiency of soybean production, the Cobb-Douglas production frontier function is estimated by applying maximum likelihood techniques to analyze factors affecting output, then the income or profit of soybean farmers. The corresponding dual cost frontier is identified from the estimated production frontier. These two frontier functions form the basis for obtaining the measurement of productive efficiency. The stochastic production frontier can be written as:

$$\ln(y_i) = \beta_0 + \sum_j \beta_j \ln(x_{ij}) + \varepsilon_i \quad (8)$$

where y_i is the output of farmer i , x_{ij} is the j input used by farmer i , and ε_i is a "composed" error term. The error term (ε_i) is explained as $\varepsilon_i = v_i - u_i$, $i = 1, 2, \dots, N$.

v_i is a two-sided ($-\infty < v < \infty$) normally distributed random error ($v \sim N[0, \sigma_v^2]$) that represents the stochastic effects outside the farmer's control (e.g., weather, natural disasters, and luck), measurement errors, and other statistical noise.

u_i is a one-sided ($u \geq 0$) efficiency component that represents the technical inefficiency of the farm (Thiam *et al.*, 2001). In other words, u_i estimates the shortfall in output y_i from its maximum value given by the stochastic frontier $\ln(y_i) = \beta_0 + \sum_j \beta_j \ln(x_{ij}) + v_i$. This one-

sided term of distribution can be half-normal, exponential, or gamma (Aigner *et al.*, 1977; Meusen & Broeck, 1977). In this study, it is assumed that u_i is a half-normal distribution ($u \sim N[0, \sigma_u^2]$) as it is typically used in the applied stochastic frontier literature. The two components v_i and u_i are also assumed to be independent of each other.

The maximum likelihood analysis of equation (8) produces consistent estimators for β , λ and σ_v^2 , where β is a vector of unknown parameters, $\lambda = \sigma_u/\sigma_v$, and $\sigma^2 = \sigma_u^2 + \sigma_v^2$. In Jondrow *et al.* (1982), inferences about the technical inefficiency of individual farmers are estimated by using the conditional distribution of u given the fitted values of ε and the respective parameters. In other words, with the assumption that v and u are independent from each other, the conditional mean of u given ε is identified by:

$$E(u_i | \varepsilon_i) = \sigma^* \left[\frac{f^*(\varepsilon_i \lambda / \sigma)}{1 - F^*(\varepsilon_i \lambda / \sigma)} - \frac{\varepsilon_i \lambda}{\sigma} \right] \quad (9)$$

where $\sigma^{*2} = \sigma_u^2 \sigma_v^2 / \sigma^2$, f^* is the standard normal density function, and F^* is the distribution function, both functions being estimated at $\varepsilon \lambda / \sigma$.

With the assumption of a half-normal model, a simple z-test will be used for examining the existence of technical inefficiency, the null and alternative hypotheses are $H_0: \lambda = 0$ and $H_1: \lambda > 0$ (Coelli, 2005). The test statistic is

$$z = \frac{\tilde{\lambda}}{se(\tilde{\lambda})} \sim N(0,1) \quad (10)$$

where $\tilde{\lambda}$ is the ML estimator of λ and $se(\tilde{\lambda})$ is the estimator for its standard error.

The technical efficiency of a farm will be determined by using the relationship:

$$TE_i = \exp(-\hat{u}_i) = \exp(-E(u_i | \varepsilon_i)) \quad (11)$$

For obtaining the estimation of v and u , we replace ε , σ^* , and λ in equations (8) and (9), then subtract v from both sides of equation (1) and finally yield the stochastic production frontier.

$$\ln(y^*_i) = \beta_0 + \sum_j \beta_j \ln(x_{ij}) - u_i = \ln(y_i) - v_i \quad (12)$$

where $\ln(y^*_i)$ is defined as the farm's observed output adjusted for the statistical noise contained in v_i .

The cost frontier dual to the production frontier can be expressed as:

$$\ln(C_i) = \alpha_0 + \sum_k \alpha_k \ln(P_{ik}) + \gamma \ln(y^*_i) \quad (13)$$

where C_i is the minimum cost to produce output y_i , P_{ik} is a vector of k^{th} input price, and α , γ is a vector of parameters.

6. Data and the empirical model

6.1 Data

Rice is a main crop in the MRD. Farmers often apply mixed farming systems such as one-rice and one-fish crop, or two-rice and one-vegetable crop to improve income and soil conditions. Consequently, farmers grow soybean once a year. The soybean crop is usually cultivated in January and February after the Winter-Spring rice crop and harvested in March and April. In this study, farmers who grow two-rice and one-soybean crop were selected for interview.

Primary data for this study were collected in a field survey in two agro-ecological areas of the MRD in 2004. Samples were collected from Can Tho Province, representing the lower reaches of the MRD and An Giang Province, representing the upper one. A total of 113 farmers, of whom 58 were in Can Tho and 55 were in An Giang, were interviewed following a stratified random sampling procedure.

6.2 Empirical model

First, the calculation of technical efficiency involves measuring the capacity of a farmer to achieve the maximum output with given and obtainable technology (Farrell, 1957; Tim *et al.*, 2005). There are several functional forms for estimating the physical relationship between inputs and output. One of the most popular functions is the Cobb-Douglas production function. In this study, the Cobb-Douglas production function is estimated with four important inputs of soybean production, namely labor, fertilizer, pesticides and machinery. The stochastic frontier model is specified as:

$$\ln(y_i) = \beta_0 + \beta_1 \ln(LAB) + \beta_2 \ln(FER) + \beta_3 \ln(PES) + \beta_4 \ln(MACH) + \varepsilon_i \quad (14)$$

where y_i is soybean output in kg, LAB is human labor used in days, FER is fertilizer quantities in kg, PES is pesticide quantities in ml, and $MACH$ is machinery service hired in days.

Deriving from the MLE estimate, the technical efficiency level of farmers may be computed using the formula of $TE_i = \exp(-\hat{u}_i)$ to eliminate the impact of random errors.

Second, the cost frontier is based on the duality of the production frontier and estimated for calculating allocative efficiency to capture a farmer's ability to apply the inputs in optimal proportions with respective prices (Farrell, 1957; Tim *et al.*, 2005). The function includes independent variables that are the price of inputs for soybean production (P_{ik}) and the total soybean output $\ln(y^*_i)$ that is adjusted for any statistical noise. The model is given as:

$$\ln(C_i) = \alpha_0 + \sum_{k=1}^4 \alpha_k \ln(P_{ik}) + \gamma \ln(y^*_i) \quad (15)$$

Last, economic efficiency, the combination of technical efficiency and allocative efficiency, is calculated by multiplying the TE score with the AE score.

Table 1 presents the descriptive statistics of some important variables applied in the stochastic frontier production function. Labor is defined as the number of working days including hired and family laborers used for land preparation, seeding, weeding, fertilizing, pesticide spraying, watering and harvest. Machinery in soybean cultivation is the number of machine service days that farmers hire from private services for preparing land, harvesting and sometimes irrigating. There are around two-thirds of farmers using machinery for harvest, one-third for land preparation and few for irrigation in the sample. In Table 1, farmers use machinery for 73 days, which is more than the hired labor and family day total of 57 days. This result reveals that machinery service utility is gradually gaining in popularity among soybean farmers. In other words, farmers are beginning to use machinery for their cultivation instead of doing it by hand. The soybean output of 1,789 kg with standard deviation of 1,492 kg indicates large variability of output among the farmers.

| | Unit | Mean | Standard Deviation | Minimum | Maximum |
|-------------|------|----------|--------------------|---------|----------|
| <i>y</i> | kg | 1,788.76 | 1,492.57 | 172.90 | 8,008.00 |
| <i>LAB</i> | days | 57.03 | 75.23 | 5.67 | 460.20 |
| <i>FER</i> | kg | 327.75 | 389.35 | - | 3,354.00 |
| <i>PES</i> | ml | 81.26 | 114.31 | 4.96 | 699.97 |
| <i>MACH</i> | days | 73.49 | 153.32 | - | 1,341.45 |

Source: Own estimates; data appendix available from authors.

Table 1. Descriptive statistics of variables in the production function

7. Results and discussion

Table 2 provides the results of the OLS estimate for choosing the relevant variables and stochastic frontier production function. The coefficient R^2 of the OLS estimation is 67 %, which shows that around 67 % of dependent variables are explained by the selected independent variables. Both models are statistically significant at the 1 % level.

The important test to check the absence of technical inefficiency effects must be done in most efficiency studies. The key parameter of log-likelihood in the half-normal model is $\lambda = \sigma_u / \sigma_v$. If $\lambda = 0$ there are no technical inefficiency effects and all deviations from frontier are due to noise (Aigner, Lovell, & Schmidt, 1977). The estimated value of $\tilde{\lambda} = 0.688$ is significantly different from 0 and the null hypothesis that the absent inefficiency effects are rejected at the 5 % level in terms of the Z-statistic (the test statistic is $Z = \tilde{\lambda} / se(\tilde{\lambda}) = 0.688 / 0.335 = 2.05$, exceeding the critical value $Z_{0.95} = 1.96$), revealing that inefficiency effects exist among soybean farmers.

For testing the proportional output change in the same proportion when inputs in the model are varied, restricted least squares regression is used with the null hypothesis of constant

returns to size. In Table 2, the function of both the OLS and stochastic frontier models is around 0.74, meaning that returns to size are decreasing. The computed F statistic is 27.24, higher than the critical value of $F(1,108) = 6.88$ at the 1 % level of significance ¹⁾. The result shows that the null hypothesis of constant returns to size is rejected. This reveals that farmers need more marginal cost for additional products, maybe due to the limitation of their knowledge about management, technologies or market information.

| Variables | OLS | | Stochastic Frontier | |
|---------------------------------|--------------|-----------------|---------------------|-----------------|
| | Coefficients | Standard Errors | Coefficients | Standard Errors |
| <i>LAB</i> | 0.161*** | 0.053 | 0.163*** | 0.053 |
| <i>FER</i> | 0.359*** | 0.057 | 0.356*** | 0.056 |
| <i>PES</i> | 0.174*** | 0.052 | 0.177*** | 0.052 |
| <i>MACH</i> | 0.042* | 0.024 | 0.041* | 0.024 |
| <i>Constant</i> | 3.932*** | 0.239 | 4.158*** | 0.422 |
| Function coefficient | 0.736 | | 0.737 | |
| F-statistic model | 54.01*** | | | |
| F-statistic CRTS | 27.24*** | | | |
| σ_v | | | 0.411 | |
| σ_u | | | 0.283 | |
| σ^2 | | | 0.249 | |
| $\lambda = \sigma_u / \sigma_v$ | | | 0.688 | |
| Log Likelihood | | | -68.83 | |
| R ² | 0.67 | | | |

Notes: 1) ***, **, * indicate statistical significance at the 0.01, 0.05 and 0.1 level respectively.

2) CRTS is constant returns to size.

Source: Own estimates; data appendix available from authors.

Table 2. OLS and Stochastic Frontier production function estimates

The ratio of the standard error of u (σ_u) to the standard error of v (σ_v), known as lambda (λ), is 0.688. Based on λ , we can derive gamma (γ) which measures the effect of technical inefficiency on the variation of observed output ($\gamma = \lambda^2 / (1 + \lambda^2) = \sigma_u^2 / \sigma_v^2$). The estimated value of γ is 0.32, which means that 32 % of the total variation in farm output is due to technical inefficiency.

This result shows that the estimated coefficient of *LAB* is statistically significant at the 1 % level for both the OLS and stochastic frontier estimates. The soybean output increases by 0.16 % for each extra percentage of labor. However, in fact the yield does not always have a positive relationship with agricultural labor in developing countries. In this study, a household with 5 members only cultivates 0.7 ha of soybeans on average. This could not create enough jobs for the members of the household; thus numbers of agricultural laborers on farms are normally higher than needed. Consequently, almost all farmers, besides attending to agricultural labor, also do some non-agricultural jobs, such as motor taxi driving or construction work, for extra income.

FER and *PES*, the most important independent variables, are statistically significant at the 1 % level for both estimated coefficients. The soybean output increases nearly 0.36 or 0.17 %, respectively, for the each additional percentage of fertilizer or pesticide applied.

The estimated coefficient of *MACH* also has significantly positive impact on the increase of output at the 10 % level. However, the soybean output does not increase so much with additional investment in machinery.

The calculation of the cost frontier dual to the production frontier is given as ²⁾:

$$\ln(C_i) = \ln(0.012) + 0.221\ln(P_{i1}) + 0.483\ln(P_{i2}) + 0.240\ln(P_{i3}) + 0.056\ln(P_{i4}) + 1.357\ln(y_i^*) \quad (16)$$

where C_i is the minimum cost of soybean production per farm measured in VND; P_{i1} is the hired price of labor in VND/man day; P_{i2} is the price of fertilizer in VND/kg; P_{i3} is the price of pesticide in VND/ml; P_{i4} is the price of machinery in VND/day and $\ln(y_i^*)$ is the soybean output adjusted for any statistical noise.

| Efficiency level (%) | Technical Efficiency | | Allocative Efficiency | | Economic Efficiency | |
|----------------------|----------------------|----|-----------------------|----|---------------------|----|
| | Number | % | Number | % | Number | % |
| >85 | 3 | 3 | 1 | 1 | 0 | 0 |
| >75≤85 | 52 | 46 | 4 | 4 | 0 | 0 |
| >65≤75 | 47 | 42 | 22 | 19 | 1 | 1 |
| >55≤65 | 10 | 9 | 24 | 21 | 7 | 6 |
| >45≤55 | 1 | 1 | 25 | 22 | 23 | 20 |
| >35≤45 | 0 | 0 | 18 | 16 | 35 | 31 |
| >25≤35 | 0 | 0 | 14 | 12 | 31 | 27 |
| >15≤25 | 0 | 0 | 4 | 4 | 14 | 12 |
| >5≤15 | 0 | 0 | 0 | 0 | 1 | 1 |
| ≤5 | 0 | 0 | 1 | 1 | 1 | 1 |
| Mean (%) | 73.9 | | 51.5 | | 38.0 | |
| Minimum (%) | 52.4 | | 4.4 | | 3.8 | |
| Maximum (%) | 86.5 | | 86.4 | | 67.5 | |

Source: Own estimates; data appendix available from authors.

Table 3. Frequency distribution of technical, allocative and economic efficiency

Table 3 shows the results of the frequency distribution of technical, allocative and economic efficiency of soybean farmers. The study reveals technical efficiency (TE) of farmers in the sample ranging from 52.4 % to 86.5 %, with an average of 73.9 %. It indicates that the average farmer in the sample could save 14.6 % (i.e., $1 - [73.9/86.5]$) of costs and the most technically inefficient could realize a 39.4 % cost saving (i.e., $1 - [52.4/86.5]$) compared with the TE level of his most efficient counterpart. In addition, the highest TE level ranging from 75 % to 90 % comprises 55 farms, which is 49 % of the total. The lowest TE score of fewer than 65 % comprises 11 farms, or 10 %, indicating that almost all farms in the sample achieve rather high technically efficient production.

The mean of allocative efficiency is only 51.5 %, with the lowest 4.4 % and the highest 86.4 %. The reason for too low an allocative efficiency score could be explained by farmers in the sample deciding the amount of inputs for cultivation only based on their experiences, not using inputs flexibly according to markets.

The economic efficiency ratio is calculated by multiplying the TE score by the AE score. Because the soybean farmers use inputs with low allocative efficiency, they also score poorly for economic efficiency with an average EE score of 38 %, the highest being 67.5 % and the lowest 3.8 %.

To analyze which factors could have an impact on the soybean productive efficiency, the Tobit model is applied with *EFFICIENCY* as a dependent variable and four independent variables, *POLICY*, *LOCAL*, *EXPERIENCE*, *AREA*, used instead of the OLS estimate that might produce biased results, often toward zero (Boris E. Bravo-Ureta and Antonio E. Pinheiro, 1997). The model can be written as:

$$EFFICIENCY = \delta_0 + \delta_1 POLICY + \delta_2 LOCAL + \delta_3 EXPERIENCE + \delta_4 \ln(AREA) + \delta_5 \ln(AREA^2) \quad (17)$$

where *EFFICIENCY* is technical efficiency, allocative efficiency or economic efficiency of farmers calculated in the previous frontier functions; *POLICY* is a dummy variable of agricultural policies; *LOCAL* is a dummy variable of a specified area, equal to 1 if Can Tho or 0 if An Giang; *EXPERIENCE* is the number of years that the farmer has grown soybeans; and *AREA* is the soybean area cultivated in 1,000m².

| Variables | TE | | AE | | EE | |
|--------------------------|--------------|-------|---------------------|-------|---------------------|-------|
| | Coefficients | t | Coefficients | t | Coefficients | t |
| <i>POLICY</i> | -0.0049 | -0.45 | 0.0397 [†] | 1.46 | 0.0293 [†] | 1.34 |
| <i>LOCAL</i> | -0.0154 | -1.45 | 0.0102 | 0.38 | -0.0001 | -0.01 |
| <i>EXPERIENCE</i> | 0.0020*** | 4.02 | 0.0002 | 0.13 | 0.0011 | 1.13 |
| <i>AREA</i> | 0.0254*** | 3.62 | -0.0801*** | -4.54 | -0.0444*** | -3.12 |
| <i>AREA</i> ² | -0.0034 | -0.98 | 0.0182** | 2.07 | 0.0112 | 1.58 |
| Constant | 0.6934*** | 39.82 | 0.5628*** | 12.86 | 0.3896*** | 11.07 |
| Sigma | 0.0558 | | 0.1404 | | 0.1129 | |

Notes: 1) ***, **, * indicate statistical significance at the 0.01, 0.05 and 0.1 level respectively.

2) † indicates one-tailed test.

Source: Own estimates; data appendix available from authors.

Table 4. Agricultural policy impacts on soybean productive efficiency

Table 4 presents the results of agricultural policies and some key factors having an impact on the productive efficiency of farmers. *POLICY* is a dummy variable trying to recognize the effect of government agricultural policies (e.g., credit, short education, input and output policies) on the efficiency of farmers. In the study, households were asked about their perceptions of some important government policies, for example credit, vocational training, and practical support by outreach services. The variable is equal to 1 if farmers have perceived benefits from one of these policies, and 0 if they do not receive any advantages from government support programs. The expectation for this coefficient is positive because efficient policies might make farmers obtain higher efficiency in their cultivation either

directly or indirectly. The *POLICY* variable is expected to be positive and so is checked by the one-tailed test. The estimated coefficient is statistically significant at the 10 % level in the AE and EE models, but insignificant in TE, indicating that policies have a partial positive effect on AE and EE in soybean cultivation.

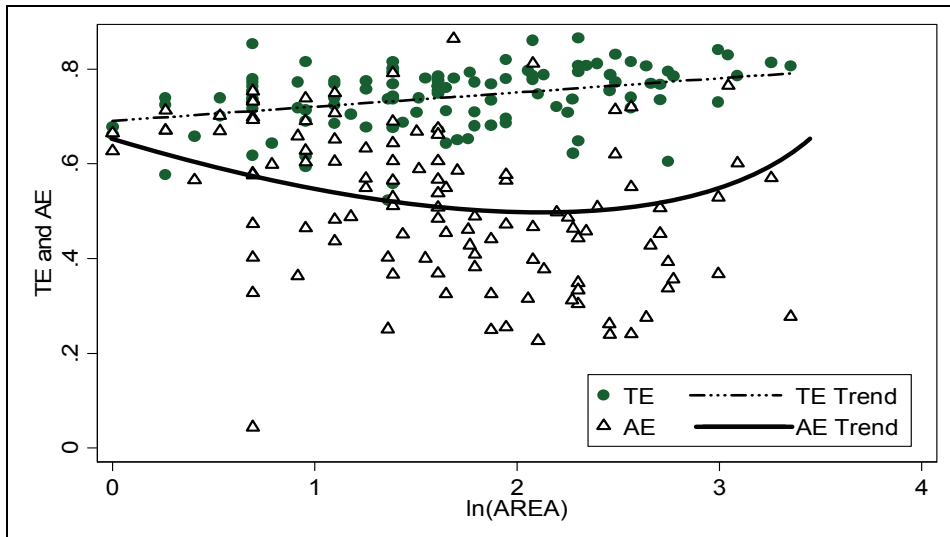

Fig. 2. The relationship between TE, AE and soybean area

LOCAL is applied for the measurement of any site-specific factors (e.g., soil fertility, differences in weather) not included in the production function that could have an impact on farms' efficiency level. The estimated result shows there is no difference in productive efficiency between the two provinces because the estimated coefficient of *LOCAL* is not significant in any of the three models.

EXPERIENCE, the number of years that farmers have been involved in soybean farming, is applied as a proxy for managerial inputs. Farmers with more years of experience may make better farming decisions and use inputs more efficiently. This coefficient is expected to be positive. In accordance with this expectation, the variable is positive. However, it is statistically significant at the 1 % level in the TE model only, and not significant in the AE or EE models. The effect of additional years of experience on technical efficiency is positive, but not for allocative or economic efficiency of farmers in the sample.

AREA, the size of soybean area cultivated, is used to capture the effect of economics of scale on the farms. The larger the soybean area that farmers cultivate, the higher the efficiency that they obtain. This coefficient is expected to be positive. It is statistically significant at 1 % in the three models. Its positive coefficient in the TE function shows that the larger the size of the farm, the more technical efficiency that farmers obtain. Moreover, the study shows that the estimated coefficient of *AREA* is negative, but $AREA^2$ is significantly positive at the 5 % level in the AE model, meaning the allocative efficiency of farmers was decreasing for cultivating additional soybean area until 0.9 ha³) and increasing after that (see Fig. 2). A possible explanation for the negative coefficient of *AREA* in the EE model is that it could partly be due to decreasing returns to size in soybean cultivation.

8. Conclusions

Agricultural yield depends mostly on differences in technology, cultivation performance and efficient production. The priority when measuring efficiency is to investigate the productive efficiency of farmers and to identify factors affecting efficiency. Since literature studies revealed that farmers in developing countries mostly do not use all potential technological resources, they often make inefficient decisions in their agricultural production. Therefore, policymakers should recognize and master important factors positively affecting the level of productive efficiency, then find suitable methods to recommend farmers grow their crops more efficiently through higher technical and economic efficiency. This study attempted to estimate soybean productive efficiency in the MRD of Vietnam and identify its determinants. The analysis estimated the TE level to be 74 %, AE to be 51 %, and EE to be 38 %. These results suggest that increase in output and decrease in cost could be obtained using available technology. The study also suggested that it is very important and useful to calculate not only TE, but also AE and EE when estimating productive efficiency.

The low AE and EE in soybean production can be attributed to the inflexible responses of farmers to changes in market prices or to their applying inputs mainly based on experience. The underlying cause is that Vietnamese farmers lack market information, which they receive mainly from their neighbors, relatives, collectors or fertilizer and pesticide shops. They often suffer from accepting a low price for their products, but paying a high price for inputs. To solve these problems and increase the AE and EE of farmers, creating better rural market information systems is recommended. There is a need for the government to supply farmers with enough market information by organizing and improving the system of market information in rural communities. This could be done by broadcasting the agricultural product information and market prices every morning, which has already been applied successfully in some communities in the Mekong River Delta.

The study also examined the relationship of the various attributes with the productive efficiency of farmers. The Tobit model was applied to analyze three separate equations, where TE, AE and EE were demonstrated as functions of four main factors: policy, locality, area and experience. The results revealed that the farmers cultivating soybeans on a large-scale achieved higher TE, but less EE due to decreasing returns to scale in soybean production. Though the average AE is low, households could receive more AE for extra soybean area cultivated above 0.9 ha. Improving farmer's cultivation experience might also help in obtaining higher TE. The government policies had a partial positive impact on increasing the AE and EE score of the farmers in the sample.

The decreasing return to size of soybean production meant that the larger the scale of the farm, the bigger the economic inefficiency. This is possibly due to limited knowledge about expenditure management, technology or market information. Thus, the government should not recommend growing soybean on a large scale unconditionally, but encourage the rotation between soybean and other vegetables such as cassava and maize in the vegetable crop period. Besides guiding farmers on how to apply new technologies, the current outreach services should include training farmers on how to manage their agricultural inputs and expenditure to adjust their resources relatively at competitive prices, which could help farmers solve decreasing returns to scale in soybean cultivation.

9. Notes

1) Calculated by the formula $F = \frac{(SSE_R - SSE_U) / J}{SSE_U / (I - K)}$, where SSE_R and SSE_U are the restricted and unrestricted sums of squared residuals and J is the number of restrictions (Coelli, 2005).

2) For the analytical derivation of a Cobb-Douglas cost function from its dual production (Varian 1992, ch. 4)

In the study, applying the formula as:

$$\ln(C_i) = \ln\left(\prod_{j=1}^4 \beta_j\right) - \frac{1}{\sum_{j=1}^4 \beta_j} \left\{ \ln \beta_0 + \ln(\beta_1^{\beta_1} \beta_2^{\beta_2} \beta_3^{\beta_3} \beta_4^{\beta_4}) \right\} +$$

$$+ \frac{\beta_1}{\sum_{j=1}^4 \beta_j} \ln(P_{i1}) + \frac{\beta_2}{\sum_{j=1}^4 \beta_j} \ln(P_{i2}) + \frac{\beta_3}{\sum_{j=1}^4 \beta_j} \ln(P_{i3}) + \frac{\beta_4}{\sum_{j=1}^4 \beta_j} \ln(P_{i4}) + \frac{1}{\sum_{j=1}^4 \beta_j} \ln(y_i^*)$$

3) At the minimum of AE curve is $\ln(\text{AREA}) = 2.2005$, equal to 0.9 ha.

10. References

- Afriat, S. N. (1972). Efficiency estimation of production functions. *International Economic Review* Vol. 13, No. 3, 568-598.
- Aigner, D. J. & Chu, S. F. (1968). On estimating the industry production function. *The American Economic Review* Vol. 58, No. 4, 826-839.
- Aigner, D. J.; Lovell, C. A. K. & Schmidt, P. (1977). Formulation and estimation of stochastic frontier production function models. *Journal of Econometrics* Vol. 6, No. 1, 21-37.
- Ali & Chaudhry, M. A. (1990). Inter-regional farm efficiency in Pakistan's Punjab: a frontier production function study. *Journal of Agricultural Economics* Vol. 41, No. 1, 62-73.
- Battese, G. E. (1992). Frontier production functions, technical efficiency and panel data: With application to paddy farmers in India. *Journal of Productivity Analysis* Vol. 3, No. 1-2, 153-169.
- Battese, G. E. & Coelli, T. J. (1995). A model for technical inefficiency effects in a stochastic frontier production function for panel data. *Empirical Economics* Vol. 20, No. 2, 325-332.
- Battese, G. E. & Corra, G. S. (1977). Estimation of a production frontier model: With application to Pastoral zone of eastern Australia. *Australian Journal of Agricultural Economics* Vol. 21, No. 3, 169-179.
- Belbase, K. & Grabowski, R. (1985). Technical efficiency in Nepalese agriculture. *The Journal of developing areas* Vol. 19, No. 4, 515-525.
- Bravo-Ureta, B. E. (1991). Dairy farm efficiency measurement using stochastic frontiers and neoclassical duality. *American Journal of Agricultural Economics* Vol. 73, No. 2, 421-428.

- Bravo-Ureta, B. E. & Evenson, R. E. (1994). Efficiency in agricultural production: The case of peasant farmers in eastern Paraguay. *Agricultural Economics* Vol. 10, No. 1, 27-37.
- Bravo-Ureta, B. E. & Pinheiro, A. E. (1993). Efficiency analysis of developing country agriculture: A review of the frontier function literature. *Agricultural and Resource Economics Review* Vol. 22, No. 1, 88-101.
- Bravo-Ureta, B. E. & Pinheiro, A. E. (1997). Technical, economic, and allocative efficiency in peasant farming: evidence from the Dominican Republic. *The Developing Economics* Vol. 35, No. 1, 48-67.
- Charnes, A.; Cooper, W. W. & Rhodes, E. (1978). Measuring the efficiency of decision making units. *European Journal of Operational Research* Vol. 2, No. 6, 429-444.
- Dey, M. M.; Paraguas, F. J.; Bimbao, G. B. & Regaspi (2000). Technical efficiency of tilapia growout pond operations in the Philippines. *Aquaculture Economics and Management* Vol. 4, No. 1/2, 33-47.
- Dwayne, B. & Loren, B. (2002). Agriculture and income distribution in rural Vietnam under economic reforms: A tale of two regions. *Working Papers*.
- Farrell, M. J. (1957). The measurement of productive efficiency. *Journal of the Royal Statistical Society. Series A (General)* Vol. 120, No. 3, 253-290.
- Jondrow, J.; Knox Lovell, C. A.; Materov, I. S. & Schmidt, P. (1982). On the estimation of technical inefficiency in the stochastic frontier production function model. *Journal of Econometrics* Vol. 19, No. 2-3, 233-238.
- Kalirajan, K. P. (1999). Frontier production functions and technical efficiency measures. *Journal of Economic Surveys* Vol. 13, No. 2, 149-172.
- Kalirajan, K. P. & Shand, R. T. (1989). A generalized measure of technical efficiency. *Applied Economics* Vol. 21, No. 1, 25-34.
- Khai, H. V. & Yabe, M. (2009). Agricultural Policy Impacts in Soybean Productive Efficiency in the Mekong Delta, Vietnam. *Journal of Rural Economics*. Special Issue, 529-536.
- Khai, H. V.; Yabe, M.; Yokogawa, H. & Sato, G. (2008). Analysis of Productive Efficiency of Soybean Production in the Mekong River Delta of Viet Nam. *Journal of the Faculty of Agriculture, Kyushu University* Vol. 53, No. 1, 271-279.
- Lovell, C. A. K. (1993). Production Frontiers and Productive Efficiency, in edited by C. A. K. L. S. Harold O.Fried & I, *The Measurement of Productive Efficiency*, Oxford University Press.
- Meeusen, W. & Broeck, J. v. D. (1977). Efficiency Estimation from Cobb-Douglas Production Functions with Composed Error. *International Economic Review* Vol. 18, No. 2, 435-444.
- Shapiro, K. H. (1977). Sources of technical efficiency: the roles of modernization and information. *Economic Development and Cultural Change* Vol. 25, No. 2, 293-310.
- Tewodros, A. K. (2001). *Farm Household Technical Efficiency: A Stochastic Frontier Analysis: A Study of Rice Producers in Mardi Watershed in the Western Development Region of Nepal*. Master thesis, The University of Bergen.
- Thiam, A.; Bravo-Ureta, B. E. & Rivas, T. E. (2001). Technical efficiency in developing country agriculture: a meta-analysis. *Agricultural Economics* Vol. 25, No. 2-3, 235-243.
- Tim Coelli, D. S. P. R. & George E.B. (2005). *An Introduction to Efficiency and Productivity Analysis*, New York, Springer Science.

Varian, H. R. (1992). *Microeconomic Analysis* W W Norton & Co Inc.

Zhiquiang, Z.; Balaji, P. & Hoaqiang, Z. A DEA Approach for Model Combination, *Proceedings of the Tenth ACM SIGKDD International Conference on Knowledge Discovery and Data Mining*, ACM New York, NY, USA, Seattle, WA, USA, pp. 755-760.

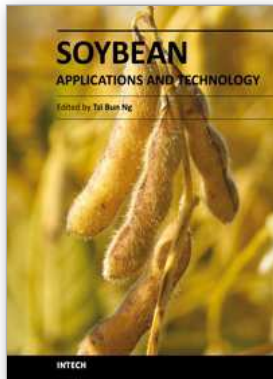

Soybean - Applications and Technology

Edited by Prof. Tzi-Bun Ng

ISBN 978-953-307-207-4

Hard cover, 402 pages

Publisher InTech

Published online 26, April, 2011

Published in print edition April, 2011

Soybean is an agricultural crop of tremendous economic importance. Soybean and food items derived from it form dietary components of numerous people, especially those living in the Orient. The health benefits of soybean have attracted the attention of nutritionists as well as common people.

How to reference

In order to correctly reference this scholarly work, feel free to copy and paste the following:

Huynh Viet Khai and Mitsuyasu Yabe (2011). Productive Efficiency of Soybean Production in the Mekong River Delta of Vietnam, *Soybean - Applications and Technology*, Prof. Tzi-Bun Ng (Ed.), ISBN: 978-953-307-207-4, InTech, Available from: <http://www.intechopen.com/books/soybean-applications-and-technology/productive-efficiency-of-soybean-production-in-the-mekong-river-delta-of-vietnam>

INTECH

open science | open minds

InTech Europe

University Campus STeP Ri
Slavka Krautzeka 83/A
51000 Rijeka, Croatia
Phone: +385 (51) 770 447
Fax: +385 (51) 686 166
www.intechopen.com

InTech China

Unit 405, Office Block, Hotel Equatorial Shanghai
No.65, Yan An Road (West), Shanghai, 200040, China
中国上海市延安西路65号上海国际贵都大饭店办公楼405单元
Phone: +86-21-62489820
Fax: +86-21-62489821

© 2011 The Author(s). Licensee IntechOpen. This chapter is distributed under the terms of the [Creative Commons Attribution-NonCommercial-ShareAlike-3.0 License](#), which permits use, distribution and reproduction for non-commercial purposes, provided the original is properly cited and derivative works building on this content are distributed under the same license.

Evaluation of Soil Moisture Status in the Field to Improve the Production of Tanbaguro Soybeans

Koki Homma
Graduate School of Agriculture, Kyoto University
Japan

1. Introduction

Tanbaguro Soybean

Tanbaguro is a generic type of soybean characterised by a black colour and large grain sizes. The weight of 100 Tanbaguro seeds is approximately 80 g, and the grains can be divided into four categories depending on the size of the grain. Namely, the grains can be classified as 3L (more than 11 mm in diameter), 2L (10 - 11 mm), L (9 - 10 mm) or M (8 - 9mm). Larger grains are preferred in certain foods such as *Nimame*, which is served during New Years celebrations. Thus, the price of large grains is relatively high. For example, 1 kg of 2L grains is often sold for more than 3,500 yen (≈ 35 \$). Although Tanbaguro was originally produced in the Tanba area (regions of Kyoto and Hyogo prefectures), Tanbaguro is now produced in other prefectures due to the high price of large grains (Fig. 1). Tanbaguro includes many cultivars (including those released by official institutions and private companies, and those raised by the producer); however, all Tanbaguro cultivars are genetically similar (Hatanaka et al., 2008).

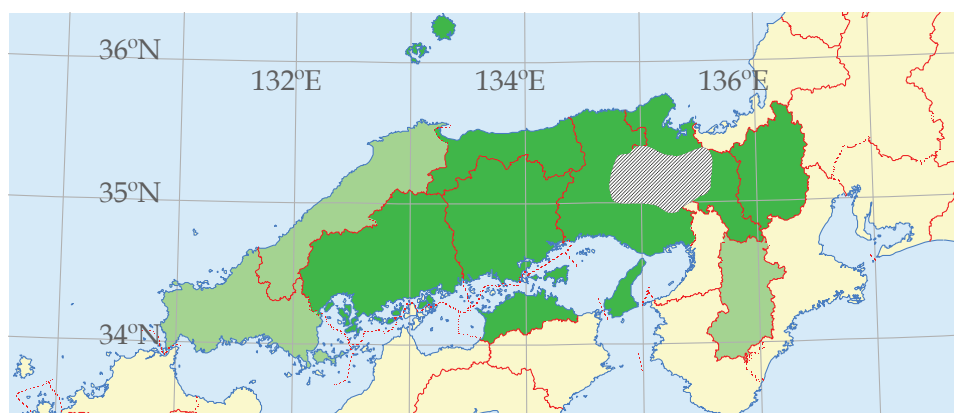

Fig. 1. Map of the Tanba area (shaded) and prefectures that produced Tanbaguro in 2006 (more than 50 t = light green; more than 100 t = green; MAFF, 2007).

After the plant is raised for 10 to 14 days in the nursery, Tanbaguro is often transplanted into the field (Matsuyama et al., 2003; Mikoshiba et al., 2009). Ridges with a height of 20 cm are prepared at 100- to 150-cm intervals, and the seedlings are transplanted to the ridges at 30- to 50-cm intervals and a plant density of 1.5 to 2.5 per m². Sparse plantings are necessary to obtain larger grain sizes.

The cultivation schedule and weather conditions of the production region are shown in Fig. 2. Because transplanting is conducted during the rainy season, water damage is often observed. After the rainy season, flowering and pod elongation occur during the summer. Thus, irrigation is one of the most important management strategies for obtaining large grain sizes and high yields. However, damage by soil born diseases such as *Phytophthora megasperma* and *Calonectria crotalariae* is common (Hinomoto, 2006) and is increased by irrigation. Thus, new strategies for water management are required.

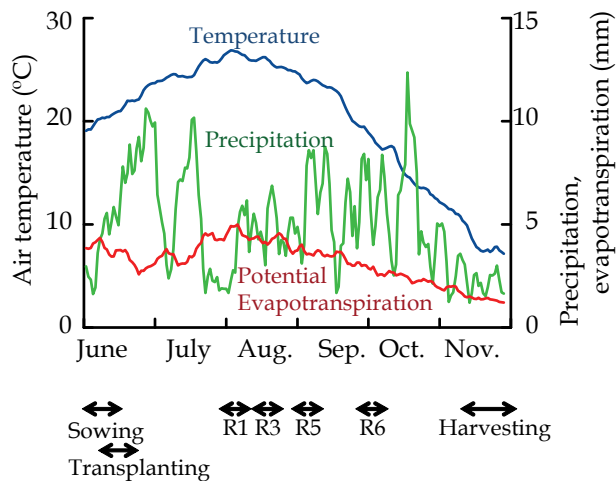

Fig. 2. Weather conditions and cultivation schedule for the production of Tanbaguro. The weather conditions are based on the 5-day-running average from 1998 to 2007 in Sonobe, Kyoto prefecture (35° 07'N, 135° 28'E). Potential evapotranspiration was estimated with the equation by Priestly & Taylor (1972). R1, R3, R5 and R6 are the developmental stages defined by Fehr & Caviness (1977) and correspond to the beginning bloom, beginning pod, beginning seed and full seed, respectively.

The present manuscript summarises the studies conducted by the author. The purpose of these studies was to provide farmers with effective and simple tools to determine the optimal timing of irrigation. To this end, three techniques were employed: (1) the use of infrared thermometers, (2) water budget simulation models and (3) the simple soil moisture meter developed by Kurose (2008).

2. Water stress index of soybean based on the difference in canopy temperature between soybean and rice

Methods for the evaluation of the plant water status based on infrared thermometers have been developed from the 1970s (Idoso et al., 1977; Jackson et al., 1981). Jackson et al. (1981)

developed the crop water stress index (CWSI), which is the most popular evaluation method and is applied to fields in the USA (Payero & Irmak, 2006). However, the canopy surface temperature and microclimate of the canopy, including the air temperature, humidity, net radiation and wind velocity, must be measured. Fields in Japan are small and widely distributed; thus, the CWSI is difficult to determine due to the cost and scale of management strategies.

Gardner et al. (1981) suggested that a well-watered plant canopy can be used as a point of reference. Although the preparation of well-watered soybean canopies is difficult, well-watered paddy fields are commonly observed in Japan. Therefore, the canopy surface temperature of rice was used as a reference (Homma & Shiraiwa, 2009). Moreover, a water stress index based on heat budget equations for soybean and rice canopies was introduced, the error of the equations was analysed, and examples of the measurements were presented.

2.1 Water stress index based on the heat budget equation (Homma & Shiraiwa, 2009)

Heat budget equations for soybean and rice canopies can be expressed by the following equations:

$$R_{nS} = H_S + \lambda E_S + G_S \quad (1)$$

$$R_{nR} = H_R + \lambda E_R + G_R \quad (2)$$

R_n is the net radiation ($W m^{-2}$), G is the soil heat flux ($W m^{-2}$), H is the sensible heat flux ($W m^{-2}$), λ is the latent heat of vaporisation ($J g^{-1}$), E is the evaporation rate ($g m^{-2} s^{-1}$), and subscripts of S and R represent the soybean or rice canopy, respectively. On a clear, sunny day, microclimate factors such as solar radiation and air temperature in soybean and rice canopies are similar. Namely, net radiation on soybean and rice canopies is nearly identical, and the soil heat flux is negligible compared to the net radiation (Campbell & Norman, 1998); thus

$$R_{nS} - G_S = R_{nR} - G_R. \quad (3)$$

Eqs. 1, 2 and 3 were combined to yield:

$$H_S + \lambda E_S = H_R + \lambda E_R. \quad (4)$$

Therefore,

$$\lambda (E_R - E_S) = H_S - H_R. \quad (5)$$

The sensible heat flux can be expressed by the following equation:

$$H_S = C_p \rho (T_{cS} - T_a) / r_{aS} \quad (6)$$

$$H_R = C_p \rho (T_{cR} - T_a) / r_{aR} \quad (7)$$

where C_p is the specific heat of air under a constant pressure ($J g^{-1} ^\circ C^{-1}$), ρ is the density of air ($g m^{-3}$), T_c is the canopy surface temperature ($^\circ C$), T_a is the air temperature ($^\circ C$), and r_a is the aerodynamic resistance ($s m^{-1}$). By substituting Eqs. 6 and 7 into Eq. 5 and assuming that the aerodynamic resistance on the soybean and rice canopy is identical ($r_{aS} = r_{aR} = r_a$), the following expression was obtained:

$$\lambda (E_R - E_S) = C_p \rho (T_{cS} - T_{cR}) / r_a \quad (8)$$

The latent heat flux on the rice canopy can be expressed by the following equation:

$$\lambda E_R = C_p \rho (e_{cR}^* - e_a) / \gamma / (r_{aR} + r_{cR}) \quad (9)$$

where e_{cR}^* is the saturated water vapour pressure at T_c (hPa), e_a is the water vapour pressure of air (hPa), γ is the psychrometric constant (hPa °C⁻¹), and r_c is the canopy resistance (s m⁻¹). After dividing both sides of Eq. 8 by λE_R and substituting Eq. 9 into the right side of the Eq. 8, the following expression was obtained:

$$1 - E_S / E_R = \gamma (1 + r_{cR} / r_a) (T_{cS} - T_{cR}) / VPD^* \quad (10)$$

where VPD* is the difference in the vapour pressure between the rice canopy and air:

$$VPD^* = e_{cR}^* - e_a \quad (11)$$

Compared to field-to-field variations in the evaporation rate of the soybean canopy, that in the ratio between the canopy resistance to the aerodynamic resistance on rice canopies is relatively low ($r_{cR}/r_a \approx \text{constant}$) because rice is cultivated under flooded conditions. Therefore,

$$1 - E_S/E_R = a (T_{cS} - T_{cR}) / VPD^* \quad (12)$$

where a is a constant. In Eq. 12, if E_S is equal to E_R (water stress conditions are not observed), the index is equal to 0. Alternatively, if E_S is equal to 0 (water stress conditions exist), then the index is equal to 1. Moreover, the right side of Eq. 12 suggests that the index is proportional to the difference in the canopy temperature of soybean and rice and is inversely proportional to the difference between the water vapour pressure of the rice canopy and air. Homma & Shiraiwa (2009) set r_{cR} to 35 s m⁻¹, and r_a to 10 s m⁻¹ on the basis of Homma et al. (1999) and Horie et al. (2006). Accordingly, a is equal to 3.0 hPa °C⁻¹.

2.2 Characteristics of the water stress index ($1 - E_S/E_R$)

As previously mentioned, the water stress index ($1 - E_S/E_R$) is proportional to the difference in canopy temperatures ($T_{cS} - T_{cR}$) and is inversely proportional to the difference in water vapour pressure (VPD^*) (Fig. 3). Thus, when $T_{cS} - T_{cR} = 3.0^\circ\text{C}$, the index is equal to 0.30 and 0.22 at a VPD^* of 30 hPa and 40 hPa, respectively.

To obtain Eq. 8, we assumed that aerodynamic resistances on soybean and rice canopies were identical ($r_{aS} = r_{aR} = r_a$). When the actual relation is $r_{aS} = x r_{aR} = x r_a$, the estimation error (e.e. = estimate based on Eq. 12 - the revision based on the actual relationship) can be obtained from the following equation:

$$\text{e.e.} = \gamma (1 + r_{cR}/r_a) (T_{cS} - T_a) (1 - 1/x) / VPD^* \quad (13)$$

The e.e. is proportional to the difference in the temperature between the soybean canopy and the air (Fig. 4a). When the actual relation is $r_{aS} = 1.1 r_a$ at $T_{cS} - T_a = 2^\circ\text{C}$ and $VPD^* = 30$ hPa, Eq. 12 overestimates $1 - E_S/E_R$ by 0.018.

To obtain Eq. 12, we assumed that the ratio of the canopy resistance to the aerodynamic resistance on the rice canopy (r_{cR}/r_a) was constant. When the actual value of r_{cR} (r_{cR}^0) is $x r_{cR}$, the e.e. can be expressed as:

$$\text{e.e.} = \gamma (r_{cR}/r_a) (T_{cS} - T_{cR}) (1 - x) / VPD^* \quad (14)$$

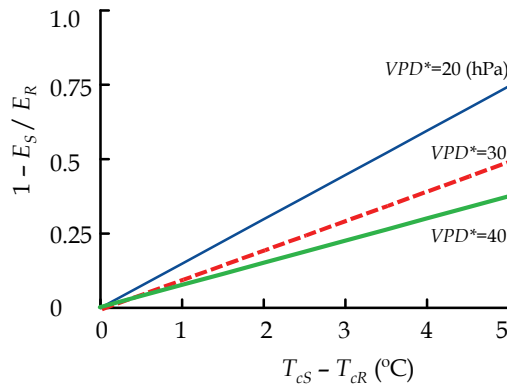

Fig. 3. The water stress index ($1 - E_S / E_R$) as a function of the difference in the canopy temperature between rice and soybean ($T_{cS} - T_{cR}$) and the difference in the vapour pressure between the rice canopy and air ($VPD^* = e^*_{cR} - e_a$) (Eq. 12).

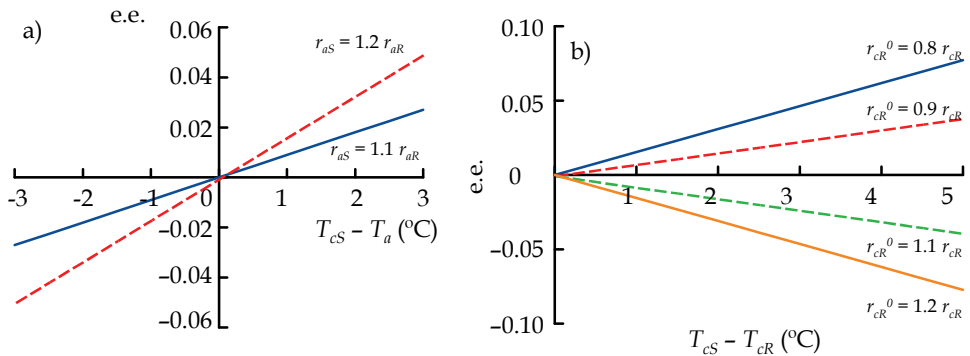

Fig. 4. Estimation error of the water stress index ($1 - E_S / E_R$) at a VPD^* of 30 hPa; (a) due to the assumption that aerodynamic resistances are the same on soybean and rice canopies ($r_{aS} = r_{aR} = r_a$; Eq. 13); (b) due to the assumption that the ratio of canopy resistance to aerodynamic resistance on rice canopies (r_{cR} / r_a) is constant (Eq. 14).

The e.e. is proportional to the difference in the canopy temperature between soybean and rice (Fig. 4b). When the actual relation is $r_{cR}^0 = 1.1 r_{cR}$ at $T_{cS} - T_{cR} = 3^\circ\text{C}$ and $VPD^* = 30$ hPa, Eq. 12 underestimates $1 - E_S / E_R$ by 0.023.

The water stress index is assumed to represent soybean and rice canopies under the same radiative conditions. However, net radiation is highly variable, even on a clear sunny day. Eqs. 7 and 9 were substituted into Eq. 2 to yield:

$$R_{nR} - G_R = C_p \rho (T_{cR} - T_a) / r_{aR} + C_p \rho (e^*_{cR} - e_a) / \gamma / (r_{aR} + r_{cR}). \tag{15}$$

When the net radiation and canopy temperature changes (R_{nR}' and T_c' , respectively), but the air temperature and water vapour pressure do not change, Eq. 15 becomes:

$$R_{nR'} - G_R = C_p \rho (T_{cR'} - T_a)/r_{aR} + C_p \rho (e_{cR'}^* - e_a)/\gamma/(r_{aR} + r_{cR}). \quad (16)$$

Subtracting Eq. 16 from Eq. 15 yields:

$$R_{nR} - R_{nR'} = C_p \rho (T_{cR} - T_{cR}')/r_{aR} + C_p \rho (e_{cR}^* - e_{acR}^*)/\gamma/(r_{aR} + r_{cR}). \quad (17)$$

The relationship between $R_{nR} - R_{nR}'$ and $T_{cR} - T_{cR}'$ is shown in Fig. 5. Although the relationship is dependent on T_{cR} , changes in the T_{cR} have a minor effect on the outcome. For instance, at a T_{cR} of 35°C, a 50 and 100 W m⁻² increase in the net radiation results in a 0.19 and 0.38°C increase in the canopy temperature, respectively. Moreover, at a VPD^* of 30 hPa, an increase in the rice canopy temperature by 0.19 and 0.38°C decreases $1 - E_s/E_R$ by 0.019 and 0.038, respectively.

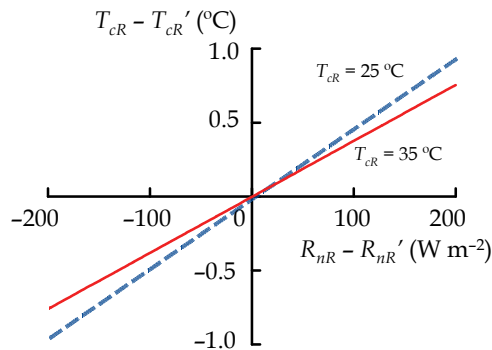

Fig. 5. The change in the surface temperature of the rice canopy ($T_{cR} - T_{cR}'$) due to net radiation ($R_{nR} - R_{nR}'$). The relationship was obtained by setting r_a and r_{cR} in Eq. 17 to 10 s m⁻¹ and 35 s m⁻¹, respectively.

Consequently, compared to the value of $1 - E_s/E_R$, the error associated with the assumptions ($r_{aS} = r_{aR} = r_a$, $r_{cR}/r_a \approx$ constant and $R_{nR} = R_{nS}$) is relatively low (approximately 10%). Although the accuracy may be inadequate for the evaluation of water stress in a well-managed experiment, the estimation is valuable in the field, where simple and quick judgments are preferable over accuracy.

2.3 Example of measurements in the field

The water stress index of 35 fields in Oyugo village, Yakuno, Kyoto prefecture (35° 20' N, 134° 56' E) was measured on August 15th and 16th of 2006, according to the proposed method. Shin-Tanbaguro soybeans (a cultivar of Tanbaguro) were planted and reached the full bloom stage (approximately 5 days after R2, according to the developmental stages proposed by Fehr & Caviness (1977)). For each soybean field, an adjacent paddy field was selected to measure the difference in the temperature of soybean and rice canopies. Koshihikari rice was planted and reached the beginning of heading. The temperature of the canopy surface was measured with a thermo tracer (TH5104, NEC Sanei Co. Ltd., Tokyo) at a depression angle of 20°. The air temperature (T_a), relative humidity (RH) and solar radiation (S_n) were measured at 5-second intervals.

The air temperature (T_a) and canopy temperature of soybean and rice (T_{cS} and T_{cR}) are shown in Fig. 6. The average \pm the standard deviation of $T_{cS} - T_a$ and $T_{cR} - T_a$ was $0.71 \pm$

1.68°C and $-1.00 \pm 1.18^\circ\text{C}$, respectively. Although T_{cR} was variable, variations in T_{cR} were lower than that in T_{cS} .

To evaluate the differences in microclimate factors (C : measurement time, T_a , RH and S_n), the mean absolute error (MAE) was determined:

$$\text{MAE} = (\sum |C_S - C_R|) / n. \tag{18}$$

In 90 of 105 evaluations as shown in Fig. 6, T_{cR} was determined less than 1 minute before or after T_{cS} . The MAE of the measurement time was 39 seconds, and T_a and RH were nearly stable over time (Fig. 7a and b). For instance, the MAE of T_a and RH was 0.23°C and 1.6%, respectively. Although S_n was highly variable, the MAE of S_n was 50 W m^{-2} (Fig. 7c). Thus, based on the results of the aforementioned analyses, the effect of the differences in microclimate factors was minor.

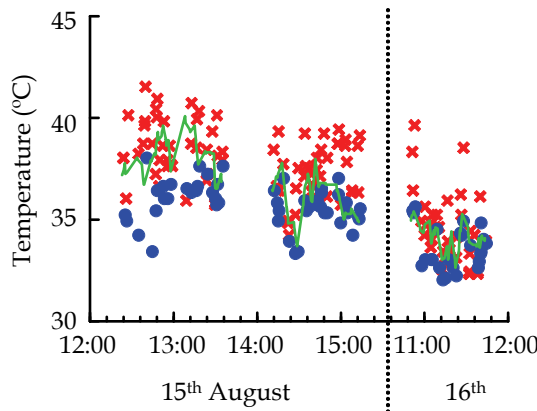

Fig. 6. Examples of measurement of air temperature (T_a : line) and canopy surface temperature of soybeans (T_{cS} : cross) and rice (T_{cR} : circle). The measurements were conducted in triplicate and were obtained from 35 fields in Oyuguo village, Yakuno, Kyoto prefecture in 2006.

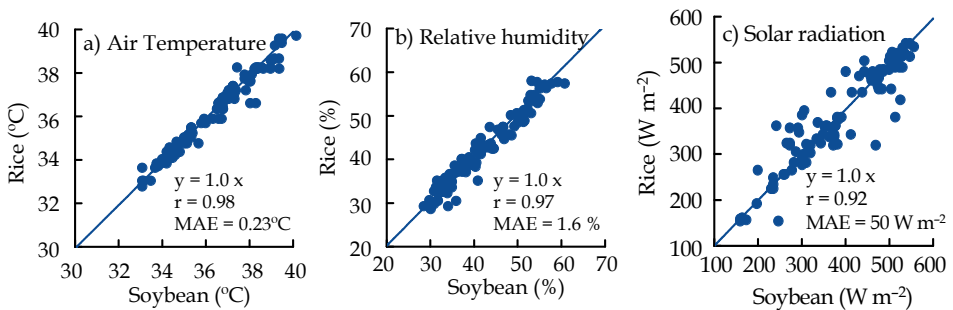

Fig. 7. The weather conditions during the measurement of the canopy surface temperature of soybean (x-axis) and rice (y-axis). MAE: mean absolute error (Eq. 18).

| Date | Start | End | T_a (°C) | S_n (W/m ²) | VPD^* (hPa) | $T_{cs}-T_a$ (°C) | $T_{cs}-T_{cr}$ (°C) | $1-E_s/E_R$ | CWSI |
|-----------|-------|-------|---------------|------------------------------|------------------|----------------------|-------------------------|-------------|------|
| 15th Aug. | 12:27 | 13:54 | 38.1 | 791 | 37.6 | 0.42 | 2.21 | 0.18 | 0.51 |
| | | | 1.0 | 55 | 3.4 | 1.88 | 1.59 | 0.14 | 0.24 |
| | 14:36 | 15:51 | 36.1 | 435 | 32.2 | 1.28 | 1.93 | 0.18 | 0.89 |
| | | | 1.1 | 144 | 3.5 | 1.51 | 1.07 | 0.11 | 0.36 |
| 16th Aug. | 10:50 | 11:55 | 34.1 | 486 | 23.5 | 0.62 | 1.19 | 0.15 | 0.63 |
| | | | 0.7 | 236 | 3.5 | 1.37 | 1.17 | 0.13 | 0.26 |

Table 1. Summary of the measurements obtained from Oyugo village, Yakuno, Kyoto prefecture in 2006 (see Fig. 6). T_a : air temperature, S_n : solar radiation, VPD^* : vapour pressure deficit between the rice canopy and air ($VPD^* = e^*_{cr} - e_a$), $T_{cs} - T_a$: temperature difference between the soybean canopy and air, $T_{cs} - T_{cr}$: temperature difference between the soybean canopy and the rice canopy, $1 - E_s/E_R$: 1- the ratio of the difference in evaporation between rice and soybean to the evaporation of rice, CWSI: crop water stress index, as defined by Jackson et al. (1981).

The water stress index ($1 - E_s/E_R$) was compared to other water stress factors such as $T_{cs} - T_a$, $T_{cs} - T_R$ and the crop water stress index (CWSI) (Table 1). To obtain the CWSI, the definition described by Jackson et al. (1981) was applied, and the net radiation (R_n) was calculated from the S_n , T_a and T_c according to the method of Campbell & Norman (1998). In the aforementioned calculations, the canopy resistance and the aerodynamic resistance were set to 35 s m⁻¹ and 10 s m⁻¹, respectively. Differences among the measuring times were the largest for $T_{cs} - T_a$ and were the smallest for $1 - E_s/E_R$. Moreover, $1 - E_s/E_R$ was less than the CWSI. Although the CWSI was higher at the measuring time from 14:36 to 15:51 than the other times, the value of $1 - E_s/E_R$ remained relatively constant (Fig. 8). Regression lines of CWSI against $1 - E_s/E_R$ were different but not significantly among measuring times. The correlation coefficient between the CWSI and $1 - E_s/E_R$ was 0.57 ($P < 0.01$). The average of standard error of $1 - E_s/E_R$ and the CWSI for each field was 0.043 and 0.118, respectively. Thus, the results suggested that $1 - E_s/E_R$ was different from the CWSI, and more stable.

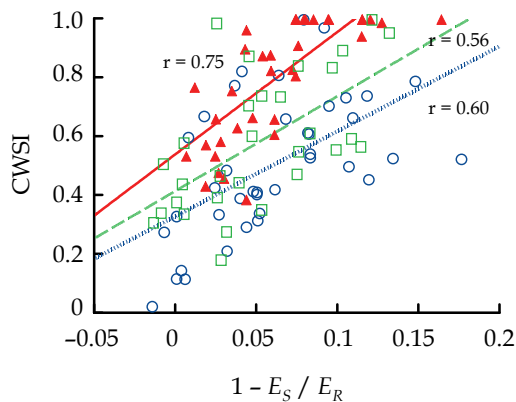

Fig. 8. A comparison of water stress indices ($1 - E_s/E_R$ and CWSI). CWSI: Crop water stress index (Jackson et al., 1981).

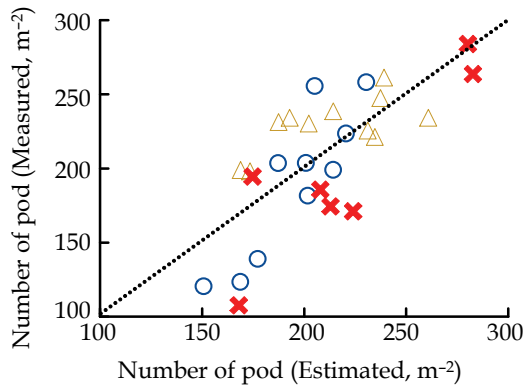

Fig. 9. The effect of water stress on the number of pods. Water stress was categorised as slight (circle; $1 - E_S/E_R = 0 - 0.15$), mild (triangle; $0.15 - 0.25$) and severe (cross; greater than 0.25). Pod number was estimated by Eq. 19.

Variations in the number of pods per unit area (P) at the study site were correlated with the leaf area index (LAI ; $r = 0.64^{**}$) and the plant density (D ; $r = 0.54^{**}$) on September 12th. The multiple regression equation of P against LAI and D explained 54% of the variation in P (Fig. 9):

$$P = 21.0 LAI + 62.4 D + 15.2 \quad (R^2 = 0.54). \tag{19}$$

Soybeans with larger values of $1 - E_S/E_R$ tended to display a lower number of pods per unit area. In fields with a $1 - E_S/E_R$ greater than 0.25 , the falling rate of pods (expressed as $1 - \text{measured } P / \text{estimated } P$) was equal to 15%. The aforementioned results suggested that the pod set was disturbed by water stress. Moreover, the evaluation method used in the present study can be used to detect the water status of the plant.

3. Application and validation of the water budget simulation model

3.1 Water budget model

When a water budget model is applied to a farmer’s field, adaptability and robustness are more important than accuracy and sensitivity. In addition, the number of parameters in the model should also be minimised. Accordingly, the water budget model developed by Ritchie (1972) was selected for the present study (Homma et al., 2008). The model is classical and has been evaluated on various occasions.

The water budget of a field can be expressed as follows (Fig. 10):

$$\Delta A_w = P_r + I_g - E_t - D_r \tag{20}$$

where A_w is the available soil water content of the root zone, P_r is precipitation, I_g is irrigation, E_t is evapotranspiration, and D_r is the drain water, which includes percolation and run off. A_w is the objective variable in the model, and E_t is determined from the following equation (Rosenthal et al., 1977):

$$\begin{aligned} E_t &= E_{tp} && (A_w \geq 0.3 \text{ AWHC}) \\ E_t &= E_{tp} A_w / (0.3 \text{ AWHC}) && (A_w < 0.3 \text{ AWHC}) \end{aligned} \tag{21}$$

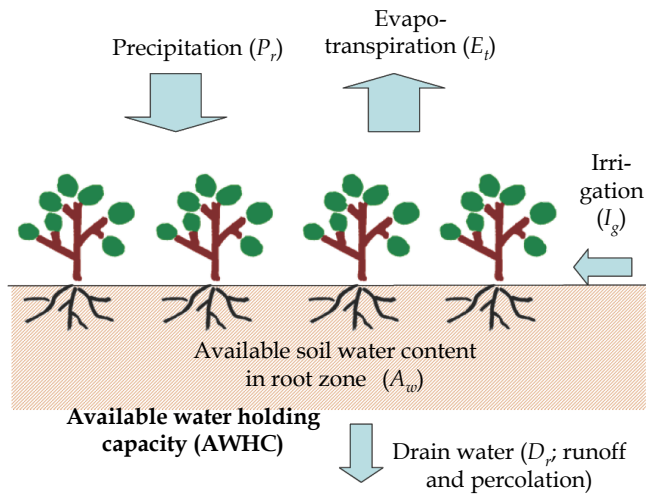

Fig. 10. Schematic illustration of the water budget of a soybean canopy (Eq. 20). In the present study, the available water holding capacity (AWHC) was used as the field specific parameter of the water budget simulation model.

where E_{tp} is the potential evapotranspiration and is estimated from the daily mean air temperature and the daily amount of solar radiation (Priestly & Taylor, 1972). AWHC is the available water holding capacity of the root zone, which is a field specific parameter. According to Eq. 21, $E_t = 0$ at $A_w = 0$. However, preliminary validation results indicated that the volumetric soil moisture content (SMC) of the plough layer decreased after $A_w = 0$ because water was supplied from the subsoil. As a result, E_t did not become equal to 0. Accordingly, the following equation was added to Eq. 21 (Fig. 11):

$$E_t = 0.2 E_{tp} \quad (A_w < 0.06 \text{ AWHC}). \quad (21')$$

In Eq. 21', negative values of A_w are possible.

When A_w is larger than the AWHC, water drains from the soil, and the amount of drain water can be obtained from the following equation:

$$D_r = b (A_w - \text{AWHC}) \quad (A_w > \text{AWHC}) \quad (22)$$

where b is a parameter that describes the percolation and run off capacity of the soil. The purpose of the model is to determine the optimal irrigation time; thus, the model will be applied during the summer months, when excess water ($A_w > \text{AWHC}$) is rarely observed. Therefore, b has a limited effect on the volume of drain water. As a result, the value of b was set to 0.8.

The following equation was used to convert A_w into SMC:

$$\text{SMC} = \text{SMC}_0 + A_w / \text{Sd} \quad (23)$$

where Sd is the depth of the effective soil layer. As shown in Eq. 23, SMC_0 is equal to SMC at $A_w = 0$. In the present study, A_w was converted into SMC to optimise the parameters and to validate the model.

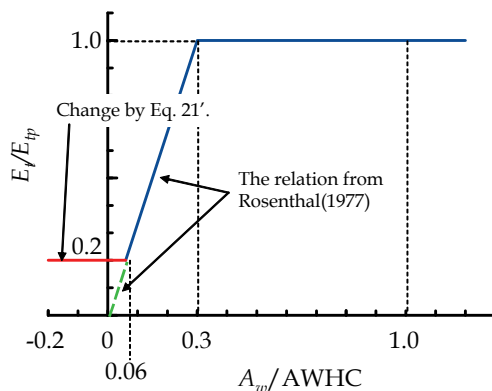

Fig. 11. Ratio of evapotranspiration to potential evapotranspiration (E_t/E_{tp}) as a function of the ratio of the available soil water content to the available water holding capacity ($A_w/AWHC$). The relationship was derived from Rosenthal (1977), and added with Eq. 21'.

3.2 Data for model validation

To validate the model, the SMC was obtained from several experiments associated with irrigation treatment for Tanbaguro (Homma et al., 2008). One experiment was conducted at the Kyoto Prefectural Agricultural Research Institute (Kyoto ARI; 35° 01'N, 135° 34'E) in 2007. In the experiment, PP beds (super drain bed, Co-op Chemical Co., LTD., Tokyo) were employed to control the amount of precipitation, irrigation and drainage. Four experiments were conducted in experimental fields in Kyoto ARI, Shiga Prefecture Agricultural Technology Promotion Center (Shiga ATPC; 35° 10'N, 136° 08'E), Nara Prefectural Agricultural Experiment Station (Nara AES; 34° 30'N, 135° 47'E) and the National Agricultural Research Center for Western Region (WeNARC; 34° 30'N, 133° 23'E). In these experiments, the SMC was measured with TDR soil moisture meters (EC-5, Decagon Devices, Inc., Pullman), and the data were collected with data loggers (Em5b, Decagon Devices, Inc., Pullman) at 6:00 AM every day. TDR sensors were placed at a depth of 20 cm from the top of the ridge.

In 2008, the model was applied to two farmer's fields. One field was located in Hiyoshi, Kyoto prefecture (35° 19'N, 135° 31'E), and the other field was located in Kyotanba, Kyoto prefecture (35° 11'N, 135° 25'E). Alternatively, in 2009, four farmer's fields were evaluated. One field was located in Sonobe (35° 07'N, 135° 28'E), Kyoto prefecture, another field was located in Yakuno, Kyoto prefecture and the other two fields were located in Sasayama, Hyogo prefecture (35° 04'N, 135° 14'E). The SMC was measured according to the aforementioned method.

For the experimental fields or PVC beds, weather data were obtained from the research institutes. Alternatively, for the farmer's fields, weather data were obtained from Japan meteorological Agency (<http://www.jma.go.jp/jma/indexe.html>).

3.2 Results of the validation

To reduce the error between the measured and estimated SMC, the simplex method, the method of nonlinear least-squares, was employed to optimise the parameters in Eq. 21 - 23

(AWHC, SMC_0 and S_d ; Fig. 12). The results indicated that the model provided the poorest fit to the experimental data obtained from the PP beds (data not shown). Alternatively, the data obtained from the farmer's fields best fit the proposed model. Thus, irrigation treatments may disturb the uniformity of the SMC , and PVC greenhouses used to protect the plant from rainfall may alter evapotranspiration, which reduces the accuracy of the estimate. Correlation coefficients between the measured and the estimated SMC were dependent on the AWHC (Fig. 13). The value of the correlation coefficient was extreme at a specific AWHC; however, relatively high correlation coefficients were obtained under a wide range of AWHCs. Thus, although the AWHC could not be accurately estimated, the variability in the SMC and A_w could be determined.

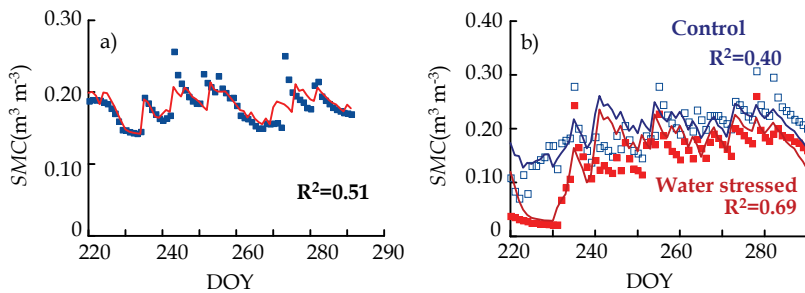

Fig. 12. Measured (symbols) and simulated (lines) soil moisture content (SMC) of (a) the PVC bed in Kyoto ARI and (b) the field experiment at Nara AES in 2007. DOY (Days of the Year) 213 = August 1st, 244 = September 1st.

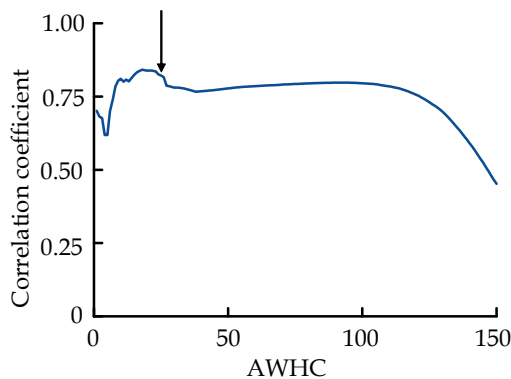

Fig. 13. The correlation coefficient between the measured and estimated SMC as a function of AWHC. The relationship was determined from the experiment shown in Fig. 12a. The arrows represent the set value of AWHC, as shown in Fig. 12a.

The model could accurately estimate differences in the SMC among irrigation treatments (Fig. 12b). The AWHC of the experimental fields varied from 34.5 to 85.9 (Table 2), and similar variations in the AWHC were observed in the farmer's fields (see Section 4). Moreover, variations in the estimated AWHC were in agreement with field observation for water holding capacity.

| | n | AWHC (mm) | Sd (mm) | SMC ₀ (m ³ m ⁻³) |
|---------------------|---|-----------|---------|--|
| Kyoto ARI | 5 | 73.9 | 389 | 0.056 |
| Shiga ATPC | 3 | 44.2 | 241 | 0.066 |
| Nara AES | 8 | 85.9 | 467 | 0.045 |
| WeNARC | 6 | 34.5 | 332 | 0.247 |
| Kyoto ARI (PVC bed) | 8 | 33.0 | 588 | 0.095 |

Table 2. Estimated parameters of the water budget simulation model: available water holding capacity (AWHC), depth of the effective soil layer (Sd) and the soil moisture content at an A_w of 0 (SMC₀).

3.2 Application of the model

Because the ratio of A_w to AWHC ($A_w/AWHC$) is associated with the ratio of evapotranspiration to potential evapotranspiration (E_i/E_{tp}) (Fig. 11), $A_w/AWHC$ can be used as a water stress index. As an example, the soil water conditions were evaluated during the irrigation experiment in Kyoto ARI. Based on the optimal AWHC, daily values of A_w and $A_w/AWHC$ were calculated from the weather data (Fig. 14). As shown in Fig. 14, water stress in non-irrigated plants in the R4 to R5 growth stage was more severe than that of non-irrigated plants in the R1 to R3 growth stage because the difference between the $A_w/AWHC$ of the control and the $A_w/AWHC$ of plants in the R4 - R5 growth stage was relatively large. The effect of weather conditions and the AWHC was evaluated in a similar fashion (Fig. 15). As shown in Fig. 15, 2008 was a drier than 2007; however, the severity of water stress was strongly dependent on the AWHC.

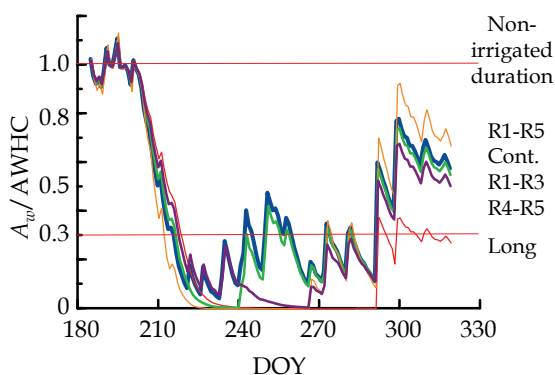

Fig. 14. Water stress conditions for the field experiment in Kyoto ARI in 2007, according to the $A_w/AWHC$.

A_w was solved as the objective variable of the model and was obtained in units of mm. Typically, soil moisture is expressed as the volumetric SMC (m³ m⁻³) or gravimetric SMC (g g⁻¹) because these parameters are easier to measure. Nevertheless, to express the

relationship to plant response, SMCs are often converted to water potentials. However, conversion is strongly dependent on many factors such as the soil texture and soil bulk density (Hillel, 1998); thus, calibration is recommended for each field. Alternatively, the comprehensive relationship between $A_w/AWHC$ and E_t/E_{tp} has been recognised since the 1970's, and many studies suggest that the threshold value of an $A_w/AWHC$ is 0.3. Namely, when $A_w/AWHC$ is less than 0.3, E_t/E_{tp} decreases linearly with a decrease in the $A_w/AWHC$ (Fig. 11; Rosenthal et al., 1977; Loomis & Connor, 1992). In addition, by solving for A_w as the objective variable, SMC_0 and S_d , namely Eq. 23, were eliminated from the model. As a result, the model was reduced to only one parameter, and the simplicity of the model was enhanced. Namely, only the amount of water such as precipitation and evapotranspiration is considered in the simplified model (Fig. 10). Thus, the model is quite suitable for application to farmer's fields. However, A_w cannot be directly measured; thus, A_w must be estimated from the SMC. To apply the model to farmer's fields without measuring the SMC, a method for the estimation of the AWHC must be applied. Therefore, we developed the method described in the following Section (Homma et al., 2010).

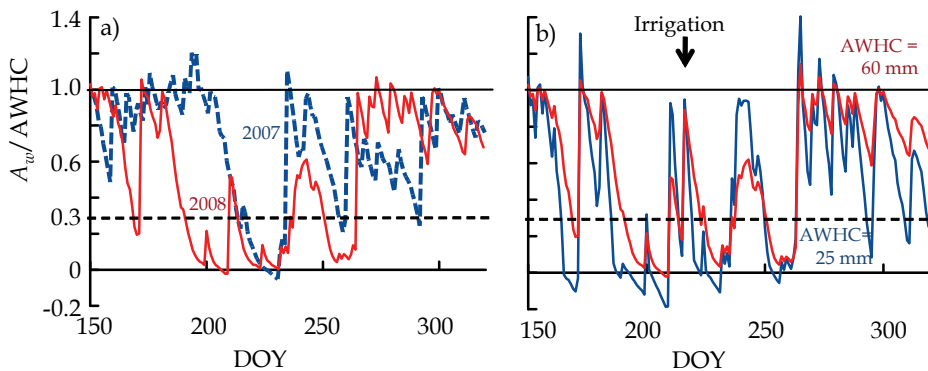

Fig. 15. The soil moisture content in Hiyoshi, Kyoto prefecture, according to the water budget simulation model; (a) fields with AWHC = 60 mm in 2007 (blue) and 2008 (red); (b) fields with AWHC = 25 mm (blue) and 60 mm (red) in 2008.

4. Estimation of the available water holding capacity (AWHC) using simple soil moisture meters

4.1 Simple soil moisture meter developed by Kurose (2008)

Kurose (2008) developed a simple soil moisture meter that can be used in farmer's fields. The fundamentals of the meter are identical to those of the ordinal soil water potential meter; however, the simple soil moisture meter contains a 1-m long clear PVC tube and does not possess a tension meter (Fig. 16). In the simplified meter, when the soil moisture becomes lower than pF 2.8, the water level in the tube decreases over time. Thus, the reduction in the water level is indicative of the accumulated water deficit, which is equal to the water deficit multiplied by the number of days. The reduction in the water level was expressed as the instrument reading (IR) in this study. In the present study, the initial and maximum IR was 0 cm and 83 cm, respectively. When the IR exceeds or will exceed the maximum value within one day, the meter must be refilled with water (reset). After the

meter is reset, the accumulated IR is obtained by combining the current IR and the previous IR (before rest). If the soil is supplied with sufficient water due to rainfall or irrigation, the IR approaches 0. In this case, the IR obtained before recovery is added to the accumulated IR , and the meter must be reset.

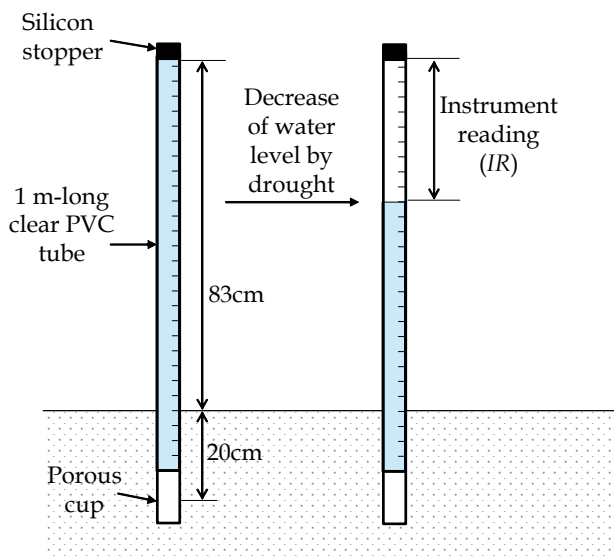

Fig. 16. Schematic illustration of the simple soil moisture meter developed by Kurose (2006). The water level in the tube decreases when soil moisture decreases below pF 2.8.

4.2 Measurements of the farmer's fields

The simple soil moisture meters were set in 15 fields in Kyotanba and 8 fields in Hiyoshi, Kyoto prefecture in 2008. The meter was vertically inserted into the top of the ridge, midway between two plants. The centre of the porous cup was adjusted to a depth of 20 cm from the top of the ridge. Three meters were used for each field, and the meters were inserted on July 11th. The water level of the meter was recorded 2 to 3 times per week until September 13th. Crop management practices such as irrigation and chemical application were conducted by the farmers. The date of irrigation was determined according to the authors' observation and compensated by interviews to farmers. Because the amount of irrigation was not measured, the volume of irrigation water was set to 50 mm.

In one of the 15 fields in Kyotanba and one of the 8 fields in Hiyoshi, the volumetric soil moisture content (SMC) was measured. TDR sensors were placed in each field, and the SMC was measured in triplicate according to the method described in the previous section (Section 3). Weather data were obtained from the Japan meteorological Agency (<http://www.jma.go.jp/jma/indexe.html>).

4.3 Estimation of the available water holding capacity (AWHC)

Similarly, the parameters in Eq. 21 - 23 (the AWHC, SMC_0 and S_d) were optimised by determining the SMC . The field in Kyotanba was optimised, and an AWHC of 30.5 mm, a

SMC₀ of 0.18 m³ m⁻³ and a Sd of 223 mm were obtained, along with an R² of 0.53. Alternatively, an AWHC of 58.0 mm, a SMC₀ of 0.09 m³ m⁻³ and a Sd of 387 mm was observed in Hiyoshi, and an R² of 0.75 was obtained. Based on the optimised parameters, the estimated SMC was in agreement with the actual SMC (Fig. 17).

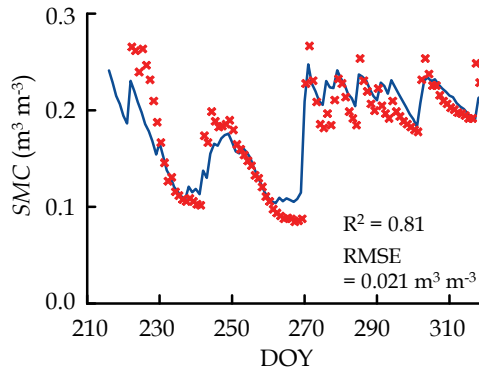

Fig. 17. Measured (symbols) and simulated (lines) soil moisture content (SMC) in Hiyoshi, Kyoto prefecture (No. 2 in Fig. 19).

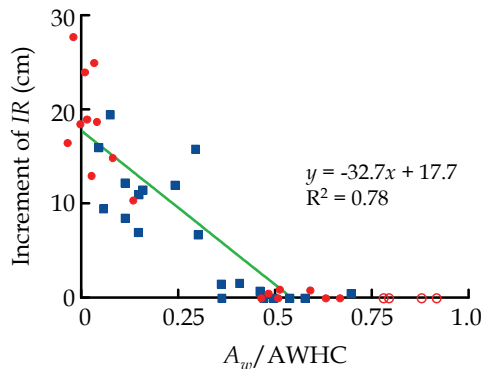

Fig. 18. The relationship between $A_w/AWHC$ and the change in the IR of the simple soil moisture meter, which was placed in fields in Tomita (circle) and Hiyoshi (square), Kyoto prefecture. The regression equation (Eq. 20) was obtained from data with an $A_w/AWHC$ lesser than 0.75.

On the basis of the optimised AWHC, daily values of $A_w/AWHC$ were calculated from the weather data and were compared to the increment of IR per day (ΔIR ; Fig. 18). Although the data were insufficient, ΔIR was almost 0 when $A_w/AWHC$ was more than 0.75. Alternatively, when $A_w/AWHC$ was less than 0.75, ΔIR increased with a decrease in the $A_w/AWHC$. Therefore, the following equation was employed to estimate the IR :

$$\begin{aligned} \Delta IR &= -31.2 A_w/AWHC + 17.3 \quad (A_w/AWHC < 0.75) \\ \Delta IR &= 0 \quad (A_w/AWHC \geq 0.75). \end{aligned} \quad (24)$$

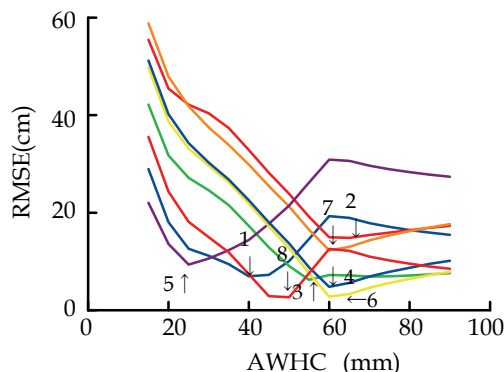

Fig. 19. The root mean square error (RMSE) of the estimated change in the IR of the simple soil moisture meter, which was placed in 8 farmer's fields in Hiyoshi, Kyoto prefecture in 2007, according to the water budget simulation model. The error was dependent on the available water holding capacity (AWHC). When the error displayed a local minimum, the AWHC of the field was determined (arrow). The numerals on the side of the arrow represent the identification number of the field.

The AWHC was optimised by determining the sum of the least squares of error between the estimated and measured IR. To apply the model to the field, the AWHC must be optimised from a limited amount of IR data. However, if the original IR is inaccurate, the error is not eliminated until the meter is reset. Accordingly, we used the change in IR over the duration to optimise the AWHC. The change in IR over 1 or 2 durations did not provide a stable estimate; thus, at least three durations were necessary to achieve satisfactory results. Therefore, to estimate the AWHC, three durations were selected from the first half of the measurement (see Fig. 20). The estimated AWHC for the field in Kyotanba and Hiyoshi was 33.5 mm and 54.3 mm, respectively. These results were in agreement with those derived from the SMC (30.5 mm and 58.0 mm for the Kyotanba field and Hiyoshi field, respectively). In fields equipped with simple soil moisture meters, the AWHC was estimated from the change in IR over three durations (Fig. 19). As shown in Fig. 19, the difference between the measured and estimated IR decreased with an increase in the AWHC, until a local minimum was attained. Subsequently, the error of the IR increased with an increase in the AWHC. In some fields, a further increase in the AWHC resulted in a local maximum, followed by a decrease in error. Beyond the local maximum, the error of the method decreased with an increase in the AWHC due to the inherent error of the estimation (i.e.; the error became equal to the average change in IR, which was used in the estimate). Thus, the first local minimum was used as the value of AWHC. The estimated AWHCs varied from 24 mm to 73 mm (39.5 mm, on average) in Kyotanba and 24 mm to 61 mm (45.4 mm, on average) in Hiyoshi. These values were in agreement with the field observations of the water holding capacity and the geographical features, and enabled us to estimate the change in IR (Fig. 20).

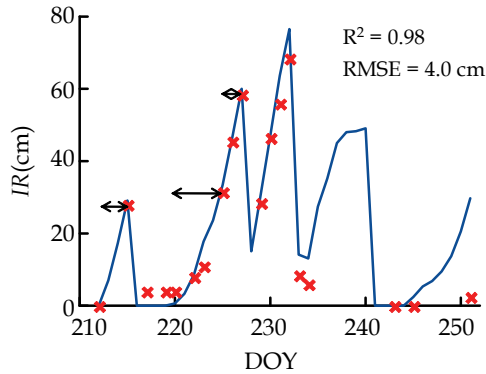

Fig. 20. The measured (symbols) and simulated (lines) instrument reading (*IR*) of the simple soil moisture meter in Hiyoshi, Kyoto prefecture (No. 6 in Fig. 19). Arrows represent the duration used to estimate the AWHC.

5. Expansion of the estimate of the available water holding capacity (AWHC) by airborne remote-sensing

To expand the study area, airborne remote-sensing was conducted to estimate the available water holding capacity (AWHC). Namely, in 2007, the temperature of the canopy surface in Sasayama was measured with a thermal airborne broadband imager (TAB1, Pasco Corp., Japan) at 10:00 on August 16th. In addition, the soil moisture in 28 fields was evaluated from July 29th to September 7th with the simple soil moisture meter. All of the measurements were conducted in triplicate.

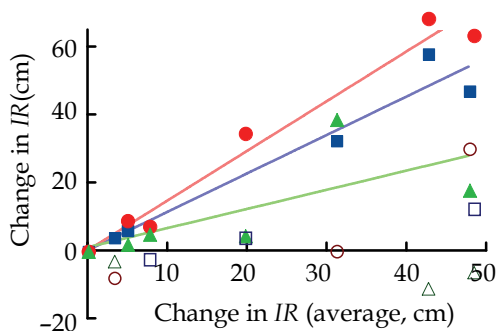

Fig. 21. The distribution of the change in instrument reading (*IR*) at each field versus the average of all 28 fields in Sasayama, Hyogo prefecture in 2007. Three of the 28 fields are shown as an example. Open symbols represent areas affected by irrigation.

Although the date and amount of irrigation must be known to estimate the AWHC from the instrument reading (IR) of a simple soil moisture meter, this information could not be obtained. Therefore, the timing of irrigation was determined by plotting the change in the IR between two consecutive measurements versus the average of the all fields (Fig. 21). In general, the IR change increased with an increase in the average; however, deviations from the linear relationship were observed and were likely caused by irrigation or error. To reduce the error between the measured and estimated IR , the AWHC was estimated after removing the observed deviations from the dataset (Fig. 22). As a result, the estimated AWHC varied from 25 to 74 mm and was geographically distributed as shown in Fig. 23a.

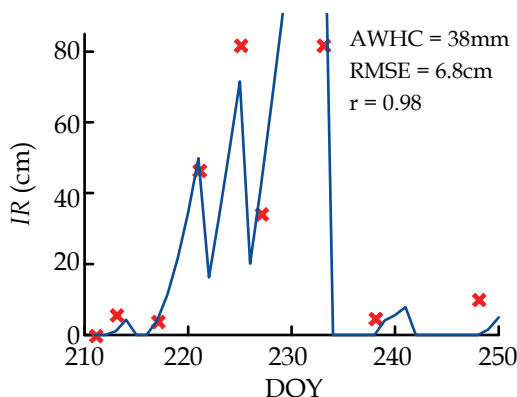

Fig. 22. The available water holding capacity (AWHC), based on the instrument reading of the simple soil moisture meter. The AWHC was determined from the root mean square error of the measured (symbol) and estimated (line) IR , which was obtained at the local minimum (see Fig. 19).

The estimated AWHC was weakly but significantly correlated with the canopy surface temperature (T_c) ($r = 0.43$, $P < 0.05$; Fig. 24). Moreover, changes in the IR over 2 days (from the 14th to the 16th of August) varied from 0 to 70 mm (Fig. 25). Twenty-three fields were normally distributed around an average IR of 35 cm, but 5 fields displayed IR s less than 5 cm and were separated from the distribution. Because the T_c of these fields was low, the fields likely received irrigation just before the T_c was measured. Upon removing the data obtained from the irrigated fields, the correlation coefficient increased to 0.59 ($P < 0.01$), and the following regression equation was obtained: $AWHC = -3.9 T_c + 182$. Using the equation, the AWHC of Tanbaguro soybean fields were estimated on the basis of the distribution of T_c , which was measured by airborne remote-sensing (Fig. 23b). As shown in Fig. 23b, geographical bias in the distribution of the AWHC was observed.

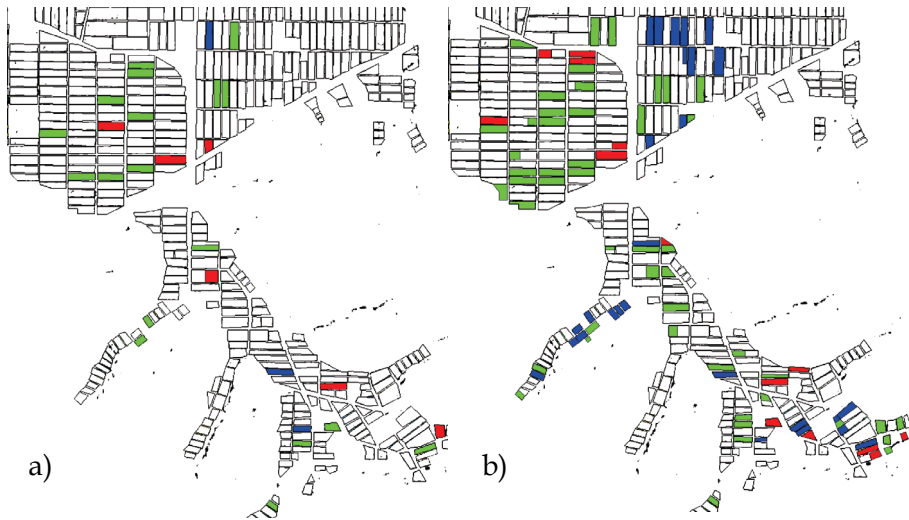

Fig. 23. The distribution of the estimated available water holding capacity (AWHC); (a) the AWHC was estimated from the results of the simple soil moisture meter, and (b) the AWHC was estimated from the canopy surface temperature. AWHC = 25 - 40 mm (red), 40 - 55 mm (green) and 55 - 74 mm (blue).

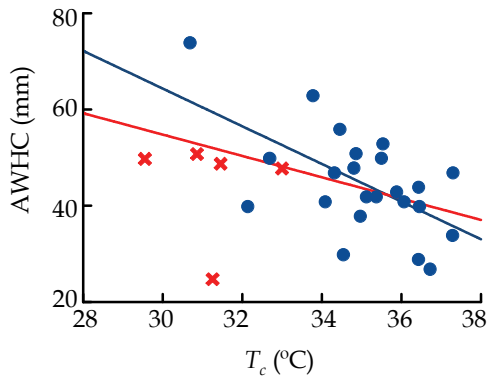

Fig. 24. The relationship between the available water holding capacity (AWHC) and the canopy surface temperature (T_c), which was measured by remote-sensing in Sasayama, Hyogo prefecture on August, 16th, 2007. Red crosses represent areas where irrigation was conducted before T_c was measured (see Fig. 25). The red line is the regression line of all of the data, and the blue line was obtained after removing data represented by red crosses.

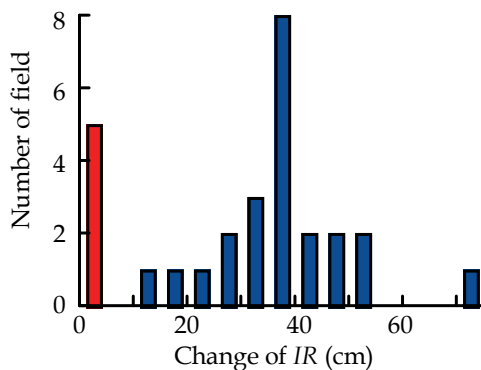

Fig. 25. Histogram of the change in the instrument reading (IR) of the simple soil moisture meter over 2 days (from the 14th to the 16th of August). When the change in IR was less than 5 cm, irrigation was likely conducted during the duration.

The measurement of T_c by air-borne remote-sensing can expand the results of the simple soil moisture meter, and the AWHC can be estimated. Because the simple soil moisture meter and the measurement of T_c were affected by irrigation, the results in the estimation of AWHC might include the effects of the amount and timing of irrigation. Thus, to accurately estimate the AWHC, the data should be obtained before the farmers conduct irrigation (before flowering).

6. Conclusions

The use of remote-sensing, water budget models and simple soil moisture meters is recommended for the evaluation of soil moisture conditions. Although the proposed methods were conducted in Tanbaguro soybean fields, the fundamental concept can be applied to other types of soybean fields or field crops. However, because the data were insufficient for the determination of the relationship between $A_w/AWHC$ and ΔIR (Fig. 18) and the relationship between AWHC and T_c (Fig. 24), the relationships should be evaluated in future studies.

Available water (A_w) is easily accessible to plants, and the A_w zone is often greater than a depth of 1 m (Loomis & Conner, 1992). However, in the present study, the volumetric SMC of the plough layer (0-20 cm in depth) was used as a reference to optimise the AWHC. The SMC of the plough layer was obtained to reduce the complexity of the measurement; however, the relationship between $A_w/AWHC$ and E_t/E_{tp} may have been altered (Fig. 11). Thus, although $A_w/AWHC$ can be used as a water index, the $A_w/AWHC$ obtained in the present study must be further evaluated. While the significance of $A_w/AWHC$ in the present study was not determined, the estimate of the IR of simple soil moisture meters by the proposed method was established. The simple soil moisture meter developed by Kurose (2008) is currently promoted by official institutes such as the WeNARC. Moreover, Okai et al. (2010) reported that an IR greater than 80 cm leads to a significant reduction in the number of pods and the yield of Tanbaguro. Sudo et al. (2010) developed a manual for the

use of simple soil meters for the production of Tanbaguro, and recommended that the crop should be irrigated before the accumulated IR reaches 80 cm. By estimating the IR , farmers can determine the optimal timing of irrigation and improve the quantity and quality of the crop.

Recently, airborne remote-sensing has been tested in agricultural fields in Japan (Sakaiya et al., 2008). For instance, Umakawa et al. (2008) measured the T_c of Tanbaguro via airborne remote-sensing, and demonstrated that T_c and stomatal aperture were strongly correlated. Although the relationship between the AWHC and the T_{cs} measured via airborne remote-sensing was evaluated in the present study (Fig. 24), the observed relationship would be stronger if T_{cR} was used as a reference and T_{cs} was converted to $1 - E_s/E_R$. Thus, the relationship between airborne remote-sensing and the water stress index ($1 - E_s/E_R$) will be evaluated in a future study.

7. References

- Campbell, G.S. & Norman, J.M. (1998) *An Introduction to Environmental Biophysics (2nd ed.)*. Springer, ISBN 978-0387949376
- Fehr, W.R. & Caviness, C.E. (1977) *Stages of Soybean Development. Special Report 80*. Cooperative Extension Service, Iowa State University
- Gardner, B.R., Blad, B.L., Garrity, D.P. & Watts D.G. (1981) Relationships between crop temperature, grain yield, evapotranspiration and phenological development in two hybrids of moisture stressed sorghum. *Irrig. Sci.* 2, 213-224, ISSN 0342-7188
- Hatanaka, T., Yoshida, S., Yagawa, M., Shibata, A., Kosaka, H. & Toda, T. (2008) The estimation of relatedness for the standardization of Tanba-guro type black soybean varieties by SSR marker. *J. Crop Res.* 53, 47-53, ISSN 1882-885X (in Japanese with English summary)
- Hillel, D. (1998) *Environmental Soil Physics*. Academic Press, San Diego, ISBN 0-123-48525-8
- Hinomoto, E. (2006) Problems for the stable and high quality production of Tanbaguro. *Hyogo no Norinsuisan Gijyutsu* 146, 4. (in Japanese)
- Homma, K., Nakagawa, H., Horie, T., Ohnishi, H., Kim, H.Y. & Ohnishi, M. (1999) Energy budget and transpiration characteristics of rice grown under elevated CO_2 and high temperature conditions as determined by remotely sensed canopy temperatures. *Jpn. J. Crop Sci.* 68, 137-145, ISSN 0011-1848 (in Japanese with English abstract)
- Homma, K., Okai, H., Ozaki, K., Kurose, Y., Doi, M., Nakai, J., Sudo, K., Ushio, A., Takeda, H., Mikoshiba, H., Shiraiwa, T. & Katsube-Tanaka, T. (2008) Development of a water balance model for "Tanbaguro" fields. *Jpn. J. Crop Sci.* 77 (Ex. 2) 132-133, ISSN 0011-1848 (in Japanese)
- Homma, K. & Shiraiwa, T. (2009) Evaluation of water stress in soybean based on the difference in canopy temperature between soybean and rice. *Jpn. J. Crop Sci.* 78, 387-394, ISSN 0011-1848 (in Japanese with English abstract)
- Homma, K., Okai, H., Kurose, Y., Sudo, K., Ozaki, K., Shiraiwa, T. & Katsube-Tanaka, T. (2010) Application of water budget equation model to farmer's fields of "Tambaguro" soybean. *J. Crop Res.* 55, 27-32, ISSN 1882-885X (in Japanese with English summary)

- Horie, T., Matsuura, S., Takai, T., Kuwasaki, K., Ohsumi, A. & Shiraiwa, T. (2006) Genotypic difference in canopy diffusive conductance measured by a new remote-sensing method and its association with the difference in yield potential in rice. *Plant Cell Environ.* 29, 653-660, ISSN 0140-7791
- Idso, S.B., Jackson, R.D. & Reginato, R.J. (1977) Remote sensing of crop yield. *Science* 196, 19-25, ISSN 0036-8075
- Jackson, R.D., Idso, S.B., Reginato, R.J. & Pinter Jr., P.J. (1981) Canopy Temperature as a Crop Water Stress Indicator. *Water Resource Res.* 17, 1133-1138, ISSN 0043-1397
- Kurose, Y. (2008) Method and equipment to measure soil moisture. Patent P07A010647, Tokyo (in Japanese)
- Loomis R.S. & Connor, D.J. (1992) *Crop Ecology*. Cambridge University Press, Cambridge, ISBN 0-521-38776-0
- MAFF (Ministry of Agriculture, Forestry and Fisheries, Japan) (2007) *Statistics on Crop in 2006*. Association of Agriculture and Forestry Statistics, Tokyo ISBN 978-4-541-03529-5
- Matsuyama, Z., Yamashita, M., Yagasaki, K. & Sato, H. (2003) *Black Soybean (Kuro Daizu)*. Rural Culture Association Japan, ISBN 978-4-540-02137-4, Tokyo (in Japanese)
- Mikoshiha, H., Homma, K., Sudo, K., Ushio, A., Okai, H., Ozaki, K. & Shiraiwa, T. (2009) Analysis of production variability of soybean 'Tanbaguro'. II. Difference in yield and planting environment among 4 villages in Tanba in 2007. *J. Crop Res.* 54, 9-17, ISSN 1882-885X (in Japanese with English summary)
- Okai, H., Ozaki, K. & Ashida, T. (2010) Relationship between pod set and water stress during flowering and pod elongation stage in 'Tanbaguro'. *J. Crop Res.* 55 (in press), ISSN 1882-885X (in Japanese with English summary)
- Payero, J.O. and S. Irmak 2006. Variable upper and lower crop water stress index baselines for corn and soybean. *Irrig. Sci.* 25, 21-32, ISSN 0342-7188
- Priestley, C.H.B. & Taylor, R.J. (1972) On the assessment of surface heat flux and evaporation using large scale parameters. *Mon. Weather Rev.* 100, 81-92, ISSN 0027-0644
- Ritchie, J.T. (1972) Model for predicting evaporation from a row crop with incomplete cover. *Water Resour. Res.* 8, 1204-1213, ISSN 0043-1397
- Rosenthal, W.D., Kanemasu, E.T., Raney, R.J., Stone, L.R. (1977) Evaluation of an evapotranspiration model for corn. *Agron. J.* 69, 461-464, ISSN 0002-1962
- Sakaiya, E., Inoue, Y. & Fujita, M. (2008) Estimating protein content of brown rice in central Tsugaru using airborne remote sensing [2]. *Jpn. J. Crop Sci.* 77, 178-179, ISSN 0011-1848 (in Japanese with English abstract)
- Sudo, K., Kawamura, H., Ashida, T., Ozaki, K., Doi, M., Shiraiwa, T., Homma, K., Katsube-Tanaka, T., Kurose, Y., Takeda, H., Mishra, K.K. & Umakawa, H. (2010) Development of decision support techniques of irrigation for stable production of black soybean on the basis of simple soil moisture meter. *Proceedings of the 169th Regular Meeting of the Society of Crop Science and Breeding in Kinki, Japan*. 26th June 2010, Faculty of Life and Environmental Sciences, Kyoto Prefectural Public University, Kyoto. P. 6.

- Umakawa, H., Sudo, K., Kurose, Y., Tachibana, K., Mishra, K.K. & Shimamura, H. (2008) Measurement of water stress with airborne remote-sensing of thermal infrared. *Proceedings of the 44th Spring Conference of the Remote Sensing Society of Japan*. P. 265-268.

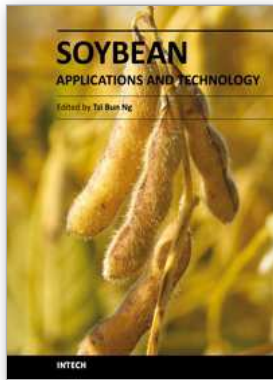

Soybean - Applications and Technology

Edited by Prof. Tzi-Bun Ng

ISBN 978-953-307-207-4

Hard cover, 402 pages

Publisher InTech

Published online 26, April, 2011

Published in print edition April, 2011

Soybean is an agricultural crop of tremendous economic importance. Soybean and food items derived from it form dietary components of numerous people, especially those living in the Orient. The health benefits of soybean have attracted the attention of nutritionists as well as common people.

How to reference

In order to correctly reference this scholarly work, feel free to copy and paste the following:

Koki Homma (2011). Evaluation of Soil Moisture Status in the Field to Improve the Production of Tanbaguro Soybeans, *Soybean - Applications and Technology*, Prof. Tzi-Bun Ng (Ed.), ISBN: 978-953-307-207-4, InTech, Available from: <http://www.intechopen.com/books/soybean-applications-and-technology/evaluation-of-soil-moisture-status-in-the-field-to-improve-the-production-of-tanbaguro-soybeans>

INTECH

open science | open minds

InTech Europe

University Campus STeP Ri
Slavka Krautzeka 83/A
51000 Rijeka, Croatia
Phone: +385 (51) 770 447
Fax: +385 (51) 686 166
www.intechopen.com

InTech China

Unit 405, Office Block, Hotel Equatorial Shanghai
No.65, Yan An Road (West), Shanghai, 200040, China
中国上海市延安西路65号上海国际贵都大饭店办公楼405单元
Phone: +86-21-62489820
Fax: +86-21-62489821

© 2011 The Author(s). Licensee IntechOpen. This chapter is distributed under the terms of the [Creative Commons Attribution-NonCommercial-ShareAlike-3.0 License](#), which permits use, distribution and reproduction for non-commercial purposes, provided the original is properly cited and derivative works building on this content are distributed under the same license.

New Applications for Soybean Biodiesel Glycerol

Vera L. P. Soares, Elizabeth R. Lachter, Jorge de A. Rodrigues Jr,
Luciano N. Batista and Regina S. V. Nascimento
*Universidade Federal do Rio de Janeiro
Brazil*

1. Introduction

Glycerol (Fig. 1.1) is a viscous and polar substance that has long been known for its useful properties. As long ago as 1779, the Swedish scientist Karl Wilhelm Scheelle obtained glycerol from olive oil. In 1813, Michael E. Chevreul showed that glycerol was involved in the triglyceride structure, and called it glycerin, from the greek word that means sweet. The elucidation of its structure as a trihydroxylated alcohol was due to Wurtz in 1855. The name glycerin was changed to glycerol to indicate its alcohol nature. It is now common to refer to the pure chemical product as glycerol and refer to the commercial grades with varying glycerol content as glycerin (or glycerine). The first example of a chemical industrial application of glycerol is nitroglycerin which was synthesized by Ascanio Sobrero. In 1860 it was transformed into a safer and more convenient form of use by Alfred Nobel [Jerôme et al, 2008; Shreve & Brink, 1977; Kirk & Otmer, 1951].

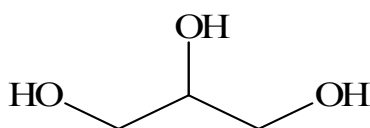

Fig. 1.1. Glycerol structure - 1,2,3-propanetriol

A large range of applications has been made possible due to its non-toxicity and biodegradability, mainly in cosmetic and food industries. As an additive in industry and in consumer goods it can be applied as a humectant, plasticizer, solvent or viscosifier, providing hydrodynamic lubrication [Kirk & Otmer, 1951]. In the polymer industry it is added as a stabilizer, plasticizer, and co-solvent in emulsion polymerization. Glycerol is also an important raw material for the synthesis of several valuable compounds. It was used as the basis for the first production of alkyd resins [Guner et al, 2006] while its partial fatty acid esters, the mono- and diesters of palmitic and stearic acids, have been widely employed as emulsifiers in processed foods. The cosmetics, pharmaceuticals and food industries account for at least 45% of glycerol production. Besides being the basis for nitroglycerin, which also finds application as a medicinal drug, glycerol is transformed in glycerol carbonate which is an intermediate in chemical synthesis and used as a gelation agent, in polyglycerols which are used in cosmetics,

in medical applications and in controlled drug release, to quote some well known glycerol derivatives and their useful applications [Berh et al, 2008; Guner et al, 2006].

The initial route to glycerol production was the hydrolysis or the saponification of triglycerides from vegetable oils or animal fats (Fig 1.2 and 1.3). This process results in crude glycerin containing approximately 88% glycerol in mass. The introduction of petroleum derived detergents brought a decline in soap production from vegetable oils which decreased the availability of glycerol. As a consequence, a synthetic route for glycerol was developed from the petroleum derivative propene, also known as propylene (Fig. 1.4), with large scale production starting in 1948, in the USA. The glycerol from both processes is purified by bi-distillation to guarantee a minimum of 99.5% purity and enable it to meet US phamacopeidia (USP) specifications that regulate products for the cosmetics, pharmaceutical and food industries.

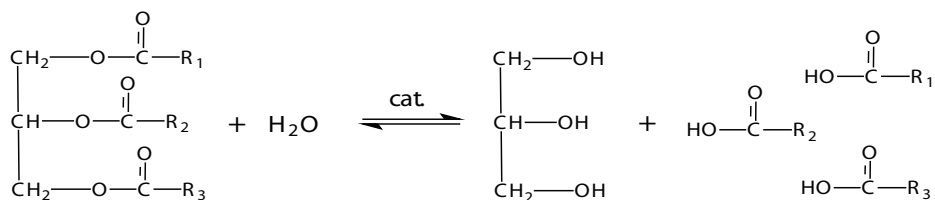

Fig. 1.2. Hydrolysis of a triglyceride showing the formation of glycerol and fatty acids

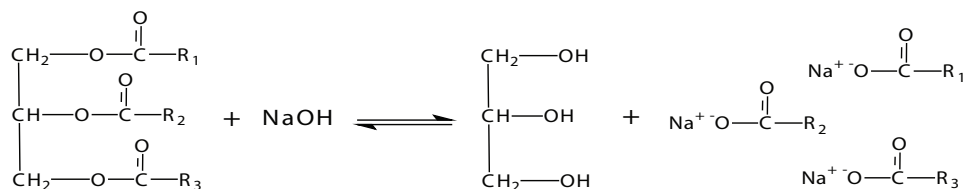

Fig. 1.3. Saponification of triglycerides showing the formation of glycerol and salts of fatty acids

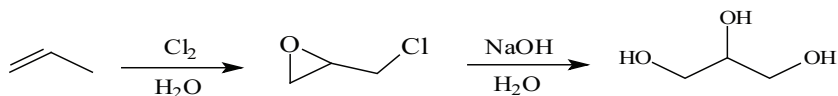

Fig. 1.4. Chemical reaction to obtain glycerol from propene, through several intermediates (Bell et. al, 2008).

The transesterification of triglycerides with methanol is the current route to biodiesel production, generating fatty acid methyl esters (biofuel) and glycerol (Fig. 1.5). It can be estimated that for each 100kg of biodiesel, around 10kg of crude glycerol are produced. Glycerol supply and demand have been kept in a reasonable equilibrium, with glycerol prices oscillating very little up to the start of the biodiesel production boom. In the last 10 years biodiesel production has had such an increase that glycerin supply has more than doubled whereas its demand has remained largely unchanged. This means that a surplus of glycerol is being added, consistently, to an otherwise stable market. As the increase of

biodiesel production is a worldwide trend, the quantity of crude glycerol being generated is considerable. Fig. 1.6 shows the enormous increase in glycerol supply after biodiesel production started all over the world.

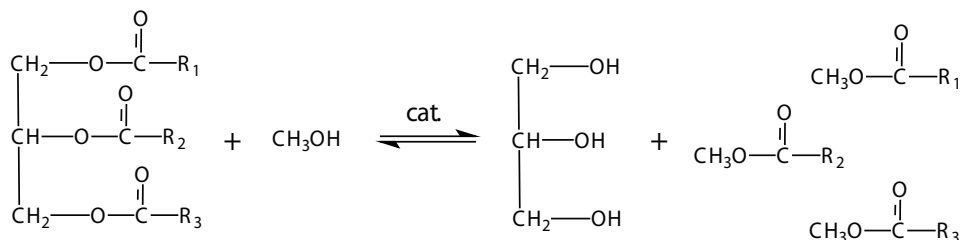

Fig. 1.5. Transesterification of triglycerides with methanol to form methyl fatty acid esters

Before considering crude glycerol for possible value-added products, it is necessary to purify it to a grade acceptable for most traditional applications. This is costly and generally not economically feasible for small to medium-sized plants. Several steps are necessary to free it of sodium salts and methanol and also of water, which needs to be treated before being discarded. This calls for large plants and investments to produce high quality and low price glycerol. The accumulation of glycerin and the difficulty to introduce its surplus in the market became a problem for some small biodiesel producers, and this led to solutions such as its discharge in rivers. It is clear that glycerin may become an environmental issue if adequate demand is not stimulated in the near future.

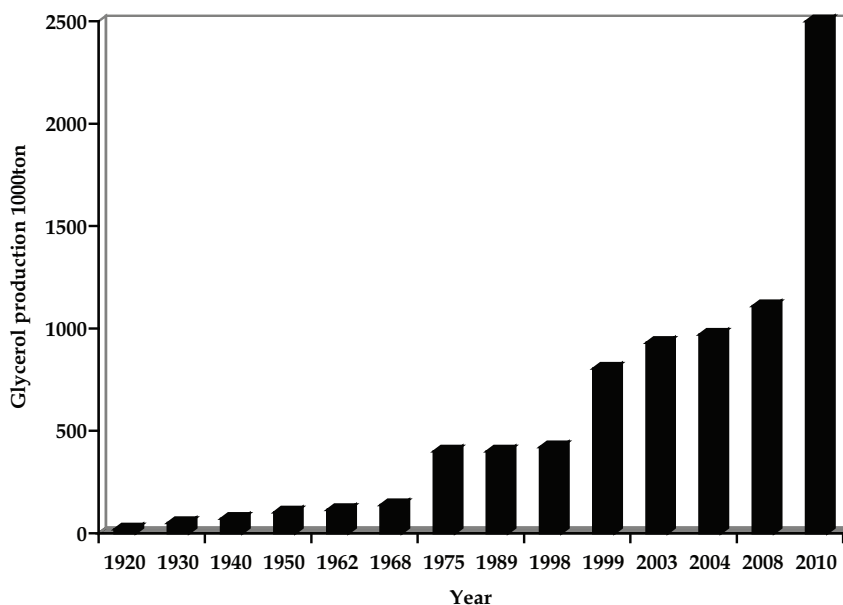

Fig. 1.6. Growth of glycerol production in the USA between 1920 and 1970 and the world production from 1975 compiled by the present authors from Shreve and Brinks, 1977 ; Kirk & Othmer, 1951; Sofiproteol, 2007.

1.1 Applications of glycerol and its derivatives: Literature review.

Alternative uses for the crude or partially purified glycerol are being pursued to make biodiesel more competitive in the growing global market. Research activities worldwide have started to focus on new applications for glycerol and its derivatives and also on processes to use glycerol as a raw material for the production of already known useful compounds.

Immediate use of glycerol as a low price substitute for polyhydroxylated alcohol (commonly abbreviated to polyols) was possible for some industrial segments, such as the paint industry, which benefits from its lubricating properties, or in cosmetic, food and pharmaceuticals industries to whose products it could be added to improve humectancy or sweetness.

The increasing price of crude oil motivated the chemical industry to search for alternatives routes for the synthesis of essential chemicals. The surplus glycerol was the main candidate for several products with a large market, in particular the monomers propylene glycol and epichlorohydrin, synthesis gas ($H_2 + CO$) and a number of other useful intermediates for the chemical process industries commonly prepared from petroleum derivatives.

1.1.1 New routes to well known products having glycerol as raw material

The investigation of processes which have glycerol as a raw material necessarily require knowledge of fundamental industrial processes such as hydrogenation, oxidation, hydrolysis, chlorination, etherification and esterification, among others. This knowledge has been the basis for the discovery and proposal of new processes for glycerol transformation into valuable products. Several literature reviews can be found that focus their presentation on these processes rather than on the product applications [Zhou et al, 2008; Jérôme et al, 2008; Berh et al, 2008].

In the last decade an important process, the aqueous phase reforming process (APR), was developed to produce the synthesis gas $H_2 + CO$ from glycerol which is an important source of hydrogen [Soares et al, 2006]. This is an alternative to the steam reforming processes of methane to prepare synthesis gas which, in its turn, is the raw material for the Fisher-Tropsch synthesis of liquid fuels; alkanes and low molecular alcohols [Suppes et al, 2005]. The development of a thermally efficient combination of the two processes resulted in the commercial production of methanol by Biomethanol Chemie Nederland [Simonetti et al, 2007]. This biomethanol can then be used in the biodiesel production. These developments made possible the economical utilization of glycerol in the production of hydrogen to be used as a fuel or as a reagent in chemical reactions.

Propylene glycol (propanediol) which has a high global demand is a monomer for the production of polyesters. It is also used as an anti-freeze fluid, and additive in cosmetics, food and pharmaceutical formulations to cite some of its uses. Its synthetic pathway has been through propylene (propene), a petroleum derivative, resulting in the formation of the isomers 1,2- and 1,3-propanediol and some ethylene glycol. It is now produced with a lower cost by the hydrogenolysis of glycerol over a copper chromite catalyst with 90% yield [Dasari et al, 2005; Shelley, 2007]. Further investigations led to a synthetic pathway for the selective preparation of 1,2-propanediol from glycerol by the Davy Process Technology [Pagliaro & Rossi, 2008]. The selective preparation of 1,3-propanediol is traditionally achieved by processes involving petroleum derivatives (dehydration of acrolein or ethylene oxide conversion), however biological process, where glycerol is the feedstock for the

fermentation process, has been proposed that can become a cheap alternative to corn syrup fermentation to produce one of the isomers preferentially [Shelley, 2007].

Another major resin ingredient compound that is already being prepared from glycerol, by its chlorination and epoxidation, is epychlorohydrin. This compound is a reagent in the synthesis of epoxy resins which are useful coating materials for marine appliances, in automotive industry and has many other applications [Guner et al, 2006]. Epychlorohydrin is traditionally prepared by propene chlorination, a process that involves one more step than the glycerol process. As glycerol used to be prepared from epychlorohydrin, the process is now reversed [Siano et al, 2006].

Yet another possibility for transforming glycerol into a value-added product is its conversion to acrolein, which is relied upon for many fine chemical products, and it is also the raw material for acrylic acid. Although its conversion from glycerol has long been known, for economic reasons the reaction has not been applied industrially; it is traditionally manufactured from propene. However, with the possibility of lower glycerol prices ahead, acrolein production from glycerol might be an elegant green alternative to the petrochemical route [Centi & Santen, 2007].

Polyglycerol is a useful derivative of glycerol which is extensively employed in controlled drug release and in cosmetics. It is comprised of several units of glycerol forming a branched ether structure with terminal hydroxyl groups. [Sunder et al, 1999; Marquez-Alvarez et al, 2004]

1.1.2 New applications for the glyceryl esters of fatty acids

A well known group of glycerol derivatives is that of mono- and diglycerides of fatty acids, usually abbreviated to MAG and DAG respectively, after the expressions monoacylglycerides and diacylglycerides. They are added to cosmetic and food formulations to prepare emulsions having components of different polarities that would otherwise separate in immiscible layers. The main glycerides are the palmitates, stearates and oleates (oleins). Their industrial production is accomplished through the direct esterification of glycerol with fatty acids or through the glycerolysis or hydrolysis of triglycerides, from vegetable oils or animal fat, which are processes that result in a mixture of mono- and diglyceryl esters [Corma et al, 2006]. An alternative route being studied is the enzymatic esterification of fatty acids with glycerol which is considered an environmentally friendly approach. Conditions for the enzymatic process are being searched to increase monoglyceride selectivity, with results of approximately 60% monoglycerides [Nandi et al, 2008; Freitas et al, 2010; Bogalhos et al, 2010]. These are good results considering that the directives of the World Health Organization for food emulsifiers require that these mixtures comprises at least 70% of both mono- and diglycerides with a minimum of 30% monoglyceride [Da Silva et al, 2000 and 2003]. To obtain MAG with a high purity for food additive usage, a purification step by distillation is required. The DAG derivatives are also a target, specifically the 1,3-isomers. These are being produced from vegetable oils and lipase by the Japanese company Kao, as a substitute for triglycerides oils for cooking due to their higher thermal stability [Watanabe et al, 2003]. A biosurfactant derived from glyceryl ester was produced by a fermentation process with a strain of *Pseudomonas aeruginosa* PA1 isolated from the water of oil production in Northeast of Brazil. They used different carbons sources (n-hexadecane, paraffinic oil, glycerol and babassu oil) and different nitrogen sources. The best results were achieved with glycerol as substrate [Santa Anna et al, 2001; Ciapila et al, 2006].

Monoglycerides are widely used as emulsifiers in food and cosmetic industries due to their active surfaces. As a consequence, their selective synthesis, by method other than the enzymatic approach, has been the object of several scientific papers in the search for a proper selective catalytic system [Abro et al, 1997; Pouilloux et al, 1999; Diaz et al, 2001, 2003, 2005; Marquez-Alvarez et al, 2004; Sakthivel et al, 2007; Jérôme et al, 2008]. Among the several heterogeneous catalysts studied, so far the best result has been 80% in selectivity at 93% conversion, using a specially tailored mesoporous material prepared by an environmentally friendly process [Karam et al, 2007]. Preparation of monoglycerides with high selectivity is a challenging issue still being investigated by researchers.

Importantly cosmetics and food markets are not increasing at the same rate as the glycerol production from biodiesel. Other markets that require compounds with lubricating and emulsifying properties could benefit from such esters derivatives. This could be the case for the fluids used for drilling wells which is a promising sector since glycerol technical grade could be used without further purification. Actually, glycerol is already a component of some formulations for water based drilling fluids in order to avoid gas hydrate formation in the well and to stabilize the water-sensitive formations, reactive shales, during drilling. [Fink, 2003; Youssif & Young, 1993; Hale & Dewan, 1989; Chenevert & Pernot, 1988; Pomerleau, 2009]. Since glycerol is a polar and highly water-soluble molecule, it cannot be used directly as an additive for boundary lubrication or as an emulsifier, while the monoglycerides, being amphiphilic molecules, can act as both. Only a few citations are found in the literature describing the use of glycerides in drilling fluids. Mueller *et al.* (2004) and Maker & Mueller (2009) developed water based drilling fluid formulations that use partial glycerides and oligoglycerides from fatty acids as lubricants. Al-Sabagh *et al* (2009) synthesized and evaluated glycerol oleates (mono-, di- and trioleate) as primary emulsifiers in oil based drilling fluids formulations. They have found that the fluid formulated with glycerol monooleate presented higher emulsion stability due to the surface activity properties of this molecule, related to its adequate hydrophilic-lipophilic balance (HLB). In the case of oil based drilling fluids where fatty acid methyl esters are the continuous phase, another problem is met related to its operation at low temperatures and high pressures, as found while drilling in deep waters. Under these conditions the drilling fluid may gellify, due to ester crystallization, which makes pumping difficult. Nascimento et al (2005) have shown the effect of several low mass esters on methyl palmitate and biodiesel crystallization behaviour and Albinante (2007) has found good results adding both partial oleins (MAG and DAG) to fatty acid methyl esters [Soares et al, 2009]. Thus, it is evident that drilling fluids represents an interesting niche to be explored for the application and development of glycerol derivatives.

One natural line of reasoning among researchers and those involved in fuel development in the search for other options for glycerol use was its conversion in oxygenated fuel additives. This would valorize the co-product of biodiesel and increase the fuel yield. Glycerol by itself can not be used as a diesel additive due to its high viscosity, its tendency to polymerize under combustion chambers conditions and, chiefly, because of its insolubility in diesel.

Given that ethers (eg methyl tertiary butyl ether) are already known to act as gasoline octane boosters, glycerol ethers (mainly tert-butyl glyceryl ether) were proposed and investigated as a fuel additive [Gupta, 1995; Klepacova et al, 2006]. In the case of gasoline it has been demonstrated that ethers from glycerol are capable of reducing particulate matter, hydrocarbons and carbon monoxide (CO) in emissions and acting as an anti-knock additive and an octane enhancer while, in biodiesel, they are capable of improving cold flow and reducing viscosity [Nouredini, 2001]. In spite of these properties a decrease in diesel and

biodiesel cetane number occurred as a consequence of the glycerol ethers branched chains [Spooner-Wyman & Appleby, 2003]. They are commercialized as gasoline additives in United States by CPS Biofuels [2010].

Other oxygenated additives are being considered as potential additives for diesel and biodiesel such as the higher glyceryl ethers, the glyceryl esters of acetic acid known as acetins, and acetals and ketals of glycerol with some patents being issued on their preparation processes [Rahmat et al, 2010; Melero et al, 2010]. This is the subject of another proposal to be presented in the following section.

1.2 Our proposals: Glycerol derivatives as fluid and fuels additives

The emulsifying and lubricating properties of glyceryl esters of fatty acids turn them into potential candidates to be applied as developed water additive to drilling fluids. This segment represents a large slice of a potential market for glycerol derivatives, solving, in part, the problem of providing a market for the glycerol excess.

Another potentially significant market to be explored for glycerol derivatives is the sector of fuels for transport. As described above, a product from glycerol is already commercialized as an octane booster for gasoline. Glycerol oxygenated compounds with properties adequated to improve diesel and/or biodiesel is another possibility to be discussed.

Additives for Drilling Fluids

Oil well drilling is performed by a complex apparatus that includes a drill pipe stem and a drill bit that perforates the formations with the aid of a drilling fluid. Drilling fluids are, in general, multi-phasic liquid systems, consisting of mixtures of solids in suspension, dissolved salts, and organic compounds dissolved or emulsified in water. These fluids play several important functions in the drilling process, including removal of the cuttings from the well, keeping the sides of the well stable, and transporting them up to the surface where they are eliminated. They are also responsible for the control of formation pressures, for sealing permeable formations, maintaining wellbore stability, minimizing formation damages and for transmitting hydraulic energy to the drilling tools to the bit. Another significant function of the drilling fluids is to lubricate the bit and the stem. It is a critical function, particularly while drilling directional wells, since the frictional forces between the drillstring and wellbore or casing are so significant that they can lead to several problems such as high torque and drag, which can lead to premature damage to the drilling tools, as a consequence of excessive wear and heat.

Drilling fluids may be air, water or oil based, depending on the nature of the continuous phase. In general, oil based fluids present lower coefficient of friction (COF) than water based fluids. However, most of the oil based fluids are not environmentally friendly and/or are considerably expensive, especially when compared with water. Thus, there is an imminent demand for new biodegradable and atoxic additives that perform as lubricants of high efficiency in water based drilling fluids.

In spite of the previously mentioned problems, oil based fluids have recently received great attention because of their high performance in drilling water-sensitive formations such as reactive shales and salt domes. Drilling these kinds of formations with water based fluids, in most cases, leads to wellbore instability problems. Reactive shales hydrate and swell in the presence of water and dome salt may dissolve significantly, both cases resulting in undesired enlargement of the well. An alternative is to work with oil based fluids. Since oil based fluids are inverted emulsions, there is no significant contact between water and the

formations, which prevents or at least minimizes wellbore instability. However, one of the main challenges in oil based fluids formulation is to obtain emulsions that persist over long periods of time. By definition, emulsions are thermodynamically unstable, because of the interfacial tension between oil and water, which increases the energy of an emulsified system, leading to emulsion breakage. Emulsions may be kinetically stabilized, for example through the use of emulsifiers, which reduce oil/water interfacial tension. There is a demand in the oil industry for high efficiency emulsifiers that are ecologically sound and have a low cost.

Molecules that have a polar segment (which has water affinity) and a nonpolar segment (which has oil affinity) show surfactant characteristics, due to their ability to adsorb at surfaces and interfaces. For this reason, these kinds of molecules are widely used as lubricant and emulsifiers. Since glycerol esters present such structural features they have a potential application in drilling fluids as lubricants and emulsifiers. Glycerol obtained from soybean biodiesel production seems to be an available and cheap resource for the production of these esters and their evaluation in drilling fluid formulation is one of our proposals.

Additives for Fuels

Compounds are added to fuel with different purposes that include the cleaning of several engine parts, the increase in combustion conversion and reduction in the emissions of undesirable or toxic substances. In diesel combustion a high level of particulates and nitrogen oxides (NO_x) are emitted. There are many techniques capable of improving combustion processes in diesel engines, such as the retarding of fuel injection, the recirculation of exhaust gas, a high pressure injection and an air intake supercharging. However due to the trade-off between the particulated matter (PM) and NO_x emissions, it is very difficult to have both reductions simultaneously [Wang et al, 2009]. One possible solution is to use oxygenated additives which are compounds capable of decreasing carbon monoxide (CO), NO_x and PM while improving the autoignition properties in diesel engines. The cetane number (CN) is the conventional term which characterizes the ignition quality and the flammability of diesel fuels. A high CN usually results in lower exhaust gas and smoke emissions, fuel consumption and engine noise, thus providing an overall better engine yield and drivability [Abu-Rachid et al, 2003].

A high cetane number depends on a high oxygen to carbon ratio and on the predominance of linear alkyl chains (high CH₂/CH₃). The capacity of some ether oxygenated additives to improve cetane number can be explained by the presence of an oxygen bridge that increase the reactivity of the hydrogen atoms in the hydrocarbon chain of the neighboring carbons contributing to the onset of combustion [Abu-Rachid et al, 2003; Marrouni et al, 2008]. For example, the comparison between CN values of dimethyl ether (DME) (55-60) and propane (-20) suggests that the 6 hydrogen atoms of the methyl groups of CH₃-O-CH₃ are much more reactive toward oxygen than the ones in CH₃-CH₂-CH₃. Table 1 compares CN of some compounds [Taylor et al, 2004].

This property led to the production of ether additives that are already commercialized as gasoline additives and stimulated further investigation on oxygenated compounds from glycerol. Three main classes of oxygenated glycerol derivatives have been developed and investigated in relation to their capacity to improve fuels properties. One such glycerol derivative is the commercialized glyceryl tert-butyl ether. Another group of ethers that has driven much attention are that of mono-, di- and triacetate of glycerol called acetins and, finally, the acetal or ketals of glycerol [Dubois et al, 2009; Melero et al, 2010].

| Hydrocarbon | Cetane number | Oxygenated Compound | Cetane Number |
|-------------|---------------|---------------------|---------------|
| Propane | -20 | Dimethyl ether | 55-78 |
| Pentane | 30 | Diethyl ether | 140-160 |
| Octane | 63,8- 65 | Hexyl methyl ether | 97 |
| Nonane | 72-74 | Dibuthyl ether | 91 - 100 |

Table 1. Cetane number of hydrocarbons and oxygenated compounds

These last proposals are based in the fact that the ketalization of glycerol hydroxyl groups retains the oxygen atoms in the molecular structure, while the esterification reduces its viscosity. The ketalization of glycerol with acetone yields the cyclic ether [3,3-dimethyl-2,4-dioxolan-4-yl] methanol (DDM), commercially known as solketal [Fig 2.1]. There are studies about the effect of a dioxolane ring on diesel emissions indicating reduction of particulate matter [Song et al, 2005; Boot et al, 2009]. In biodiesel, it has improved oxidative stability and low temperature properties [Melero et al, 2010]. This compound was the object of some patents. Delfort et al (2005) produced DDM and other analogous ketals derivatives to be used as diesel additives. Puche (2003) described a procedure to obtain a biodiesel with improved properties at low temperature, using DDM as component. Hillion et al (2005) described a method to produce biodiesel, ethers and soluble glycerol acetals. Miller et al (2008) presented an innovative procedure using reactive distillation to prepare biodiesel and DDM on the same process using acid catalyst, without a pre-separation of glycerol.

None of the above proposals contemplate a structure of a ketal-glyceryl ester. A compound containing both ester and ether groups could benefit from each group property. The ether group would be responsible for a better ignition whereas the ester group would provide a better lubricity. In this manner a single compound would provide both properties. In applying this concept to glycerol ketal, it is proposed that the glycerol hydroxyl be esterified with long chain fatty acids as the long hydrocarbon chains would then behave as a fuel just as in biodiesel. One could think of a fuel in a similar way to biodiesel in which the methanol had been changed by an alcohol prepared from the ketal-glycerol (DDM in this case). One such derivative has been proposed that uses the short chain acetic acid [Garcia et al, 2008]. Similarly to glycerol ethers, this ketal-glyceryl acetate compound is a volatile product and, consequently, it can only be added to diesel and biodiesel in low concentrations in order to not affect diesel and biodiesel volatilization behaviour. A glycerol derivative that could contribute to diesel and biodiesel performance would create a large market for this co-product.

This paper presents the preliminary studies on the evaluation of thermal properties of ketal-glyceryl esters of long chain fatty acids developed to perform as a biofuel additive and the study of their influence on the soybean biodiesel thermal properties. The paper also presents some results on the performance of glycerol esters in drilling fluids as lubricants for water based drilling fluids and as emulsifiers and anti-crystallization additives for oil based drilling fluids.

2. Methods

The synthetic routes for the preparation of several glyceryl esters and ketal-glyceryl esters both derived from fatty acids and their respective characterization methods are described. The techniques employed to essay their applications as lubricifiers, emulsifiers and anti-crystallization additives in drilling fluids and as a cetane enhancer additive in biodiesel are presented.

2.1 Preparation and characterization of glyceryl esters

The esterification reactions of glycerol with saturated and unsaturated carboxylic acids (octanoic, decanoic, dodecanoic and 9-(cis)-octadecenoic or oleic), catalyzed by p-toluenesulfonic acid, were conducted under a nitrogen atmosphere, at 125°C for 3 to 5h. The glycerol:acid molar proportion was 3:1 and 6:1 [Yaakoub, 2007]. A scheme for the esterification reaction is presented in Fig. 2.1.

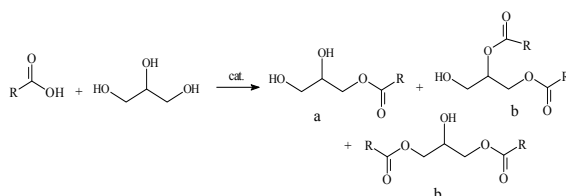

Fig. 2.1. Esterification of glycerol with carboxylic acids showing the products structures (a) monoglyceride (b) diglyceride. R represents a hydrocarbon chain having 9 to 17 carbon atoms.

The reaction mixture was washed with water to extract glycerol and ethyl ether was added to the organic phase containing the esters. After being dried with anhydrous magnesium sulfate, the solvent was evaporated and the product submitted to Fourier-transformed infrared (FTIR) and to ¹H e ¹³C nuclear magnetic resonance (NMR) analyses. By this reaction process both mono- and diglycerides were obtained as shown by FTIR that revealed ester carbonyl absorption bands (1745cm⁻¹), hydroxyl groups and the disappearance of acid carbonyls. Due to its nondestructive and noninvasive character, NMR spectroscopy provides the most convenient method for the determination of acyl positional distribution in glyceryl esters [Simova et al, 2003]. NMR allowed the quantitative determination of monoglycerides, diglycerides and acid conversion. Acid conversions for all reactions were found above 70%. The reaction performed at 6:1 resulted in higher monoglycerides proportions and the product of these reactions were used in application essays. These analytical results are presented in table 2.1.

| Glyceryl Esters | Partial Ester distribution determined by ¹³ C- NMR | | |
|--------------------|---|------|-----|
| | Mono | Di | Tri |
| Glyceryl octanoate | 80.6 | 19.4 | - |
| Glyceryl decanoate | 77.5 | 18.7 | 3.8 |
| Glyceryl laurate | 78.5 | 21.5 | - |
| Glyceryl Oleate | 75.5 | 25.5 | - |
| Glyceryl Oleate | 60 | 40 | - |

Table 2.1. Glyceryl esters distribution as determined by ¹³C- NMR.

2.2 Evaluation of glyceryl esters in drilling fluids

The glyceryl esters, containing mainly monoglycerides, were evaluated as lubricants in water based fluids formulations and as emulsifiers in oil based fluids formulations. First, the

general procedure for the drilling fluids formulations is described, followed by the specific techniques used to evaluate the additives for each of the desired properties. Finally, glyceryl oleate was evaluated as an anti-crystallizing additive for fatty acid methyl esters, used in ester oil based fluids.

2.2.1 Drilling fluids formulations

Several drilling fluids were formulated using the synthesized glyceryl esters as lubricants, in water based formulations, or emulsifiers in oil based formulations. The synthesized glycerides contained a minimum of 60% of monoglyceride, as presented in the section 2.1. Both water and oil based fluids were formulated in Hamilton Beach® shakers. The general compositions of the water and oil based fluids are respectively presented at Tables 2.2 and 2.3. At table 2.2, the lubricant component was either polyethyleneglycol 400 dioleate (a commercial lubricant for water based fluids) or the synthesized glyceryl esters. At table 2.3, the emulsifier component was either sorbitan monooleate (a commercial emulsifier for water-in-oil emulsions) or the synthesized glyceride.

| Component | Amount | Function |
|---------------------------|--------------|-------------------|
| Water | Up to 350 ml | Base |
| Xanthan Gum | 2.5 g | Rheology modifier |
| Hydroxypropyl amide (HPA) | 2.0 g | Filtrate control |
| PDADMAC ¹ | 3.0 wt% | Shale inhibition |
| Potassium Chloride (KCl) | 3.0 wt% | Shale inhibition |
| Sodium Hydroxide (NaOH) | pH 9,0 | pH control |
| Barite | 28.0 g | Weight control |
| Lubricant | 7.0g | Lubricant |

¹ Polydiallyl dimethyl ammonium chloride, cationic polymer

Table 2.2. General water based fluids composition and the components functions

| Component | Amount | Function |
|-----------------------------|---------|------------------|
| <i>n</i> -paraffin | 157.5 g | Base |
| Brine (10wt% NaCl in water) | 140.0 g | Dipersed phase |
| Emulsifier | 11.78 g | Emulsifier |
| Tween® 80 ¹ | 2.22 g | Co-emulsifier |
| ECOTROL® ² | 2.25 g | Filtrate control |
| Barite | 28.0 g | Weight control |

¹ polyoxyethylene sorbitan monooleate; ² polymeric additive produced by MI-SWACO

Table 2.3. General oil based fluids composition and the components functions

2.2.2 Lubricity measurements

Efficiency of the synthesized additives as lubricants in water based fluids formulations was evaluated through coefficient of friction (COF) measurements, in a Baroid Lubricity Tester

Model 212. In the experiments, a steel test block that simulates the well casing is pressed against a test ring by a torque arm. The torque is measured by intensity of current that is required to turn the ring at a constant rpm when immersed in the evaluated formulation. The applied rotational velocity and torque were, respectively, 60 rpm and 150 lb/inch, following the API procedure (RP 13B). Under these conditions, torque readings are related to COF by $\text{COF} = \text{torque reading}/135.5$, where COF is a dimensionless value. All the measurements in this work were performed at room temperature.

2.2.3 Determination of the relative stability of the emulsion

The efficiency of the synthesized additives as emulsifiers in oil based fluids formulations was evaluated through Electrical Stability (ES) tests. In these experiments, a pair of permanently spaced electrode plates is immersed in a fluid emulsion sample, and an increasing AC voltage is applied to the electrodes in a constant rate. The voltage at which the emulsion allows the current to flow is reported as relative emulsion stability (ES). High values of ES mean more kinetically stable emulsions, since a higher voltage is required to promote emulsion breakage. A commercial glyceryl oleate containing 50% of each partial ester was also essayed as emulsifier.

2.2.4 Evaluation of glyceryl ester as an anti-crystallizing agent

The anticrystallizing effect of a glyceryl oleate containing mono-, di- and triester in the proportion 60:37:3, respectively, was tested in an ester base drilling fluid consisting of a mixture of methyl fatty acid esters. These methyl esters were a commercial preparation obtained from Miracema, SA, Brazil, that will be named FAME to differentiate from other fatty acid methyl esters prepared to be used for other purposes. The FAME base fluid containing 5% of the additive in moles per weight and without the additive were both submitted to analysis in a Perkin Elmer, model 7, differential scanning calorimeter (DSC), for the determination of their temperatures of crystallization. These measurements were conducted in dynamic mode at a cooling rate of 10°C/min, from room temperature down to -35°C, in a nitrogen atmosphere. Isothermal measurements for the determination of the induction time for crystallization were conducted by visual inspection, at the bench, of the same solutions kept in a water-salt bath at -4°C.

2.3 Preparation and characterization of ketal-esters of glycerol

Preparation of the product of interest - (2,2-dimethyl-1,3-dioxolan-4-yl) methyl ester, product II shown in Fig 2.2-II, involved the ketalization of glycerol to (2,2-dimethyl-1,3-dioxolan-4-yl) methanol (product I shown in Fig 2.2-I) in a first step and the esterification of this intermediate in a second step. In the first step, a mixture of glycerol, propanone in excess, p-toluenesulfonic acid (catalyst) and chloroform were refluxed for 10h, while the water that was being formed was simultaneously removed by azeotropic distillation at 49°C. A Dean-Stark apparatus helped to separate the distilled solvent from the water so as to return it to the reaction flask. The ketal-glycerol (I) was isolated by: adding sodium carbonate to neutralize the catalyst, filtration of the catalyst and vacuum fractional distillation. The second step was the transesterification of product I with a mixture of methyl esters derived from palmitic (hexadecanoic), oleic (9-(cis)-octadecenoic) and stearic (octadecanoic) acids, for 6h at 125-140°C, in the presence of anhydrous sodium carbonate, to generate product II. This product was purified by filtration of the catalyst and distillation of

the excess of product I. The transesterification of methyl palmitate with product I was also conducted which produced (2, 2-dimethyl-1,3-dioxolan-4-yl) methyl palmitate (PDM).

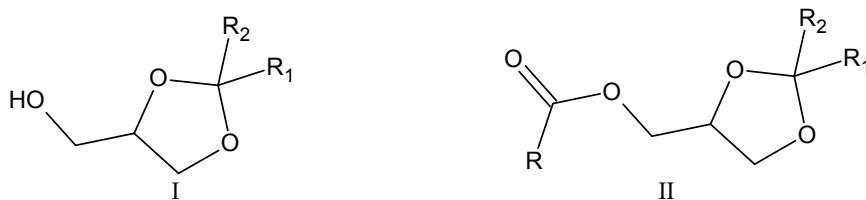

Fig. 2.2. Structure of intermediate I and product II (R =15-17 carbons; R₁, R₂ = CH₃)

These products were analysed by Fourier-transformed infrared spectrometry (FTIR) in a Nicolet, model Magma 750, by nuclear resonance spectrometry (¹H and ¹³C NMR) in a Bruker apparatus, Avance 200, at 200 and 50MHz, respectively, and by gas chromatography with mass detector (CG-MS) in a GC Agilent 5500. These analyses confirmed the formation of the ketals (I) and the ketal-esters (II). The FTIR spectra of the ketals (I) after distillation presented: the typical C-O band at 1090cm⁻¹, which differs from that of glycerol (1042cm⁻¹), an OH band at 3404cm⁻¹ relative to the non-reacted-hydroxyl, as expected, and the typical CH₃ bend vibration from the acetylonyl radical at 1375cm⁻¹. The presence of a ketal C-O bond was signalled by the ¹³C-NMR spectra at 109.4 ppm. The FTIR spectra of ketal-glycerol esters (II) showed typical ester bands at 1734cm⁻¹ and 1200cm⁻¹ and the absence of acid OH bands, while ¹³C- NMR spectra showed chemical shifts at 173.6 and 174.3ppm for ester carbonyls, besides that for ketal carbon at 109ppm. The carbonyl displacement at 174.3ppm was due to residual methyl ester from the transesterification step. The chromatographic analysis (with mass detector) also confirmed the presence of ketal-ester and residual methyl esters (Batista, 2008). Two product batches were prepared so as to contain the glycerol-ketal esters and biodiesel in the proportions 65:35 (BDM65) and 25:75 (BDM25), respectively. A commercial biodiesel from soybean oil was used. These two mixtures were evaluated in relation to some fuel critical thermal properties.

2.5 Evaluation of ketal-glycerol esters properties as fuel additives

The two products batches BDM65 and BDM25 containing ketal-glycerol esters and biodiesel were evaluated in relation to the following thermal properties: temperature of crystallization at a cooling rate of 10°C/min in N₂ atmosphere and oxidation stability from 30 to 300°C in air atmosphere in a differential scanning calorimeter (Perkin-Elmer model 7); and distillation behaviour according to ASTM D1160. A sample of biodiesel and a sample of (2, 2-dimethyl-1,3-dioxolan-4-yl) methyl palmitate (PDM) were analysed under the same conditions.

3. Results

The glycerol esters synthesized were assayed in relation to their performance: as a lubricant in water based drilling fluid, as an emulsifier in oil based drilling fluids and as an anti-crystallizing agent in ester (FAME) based drilling fluids. The ketal-glycerol oleate was assayed in relation to its thermal properties that could affect those of biodiesel.

3.1 Glyceryl esters as lubricant for water based drilling fluid

Adsorption lubricants in an oil medium are widely known as surfactant molecules that adsorb onto surfaces, minimizing the direct contact between those surfaces. In this lubricity model, the lubricant molecule must have a polar segment that strongly adsorbs onto the surface, and a long apolar chain, which interact their neighbours chains through weak Van der Waals forces, differently from the unlubricated surface, where strong interactions cause friction. However, in an aqueous medium this mechanism is difficult because even if the polar segment has good interaction with the surface, the apolar segment does not have a favorable interaction with water, leading to phase separation, instead of adsorption. The control of this equilibrium is a key challenge in the development of lubricants for aqueous systems.

In this work, the potential of synthesized glycerides are evaluated as lubricants in water based drilling fluids formulations. Table 3.1 presents the results obtained for the coefficient of friction (COF) measurements in formulations containing different lubricants at 2 wt%. The content of monoglycerides in these products is presented in table 2.1. All the systems containing the glyceryl esters presented considerably low COF values, when compared with the fluid without lubricant. In addition, their performance was even better than that obtained with the commercial lubricant used in aqueous formulations, polyethyleneglycol 400 dioleate.

| Lubricant (2,0 wt%) | COF of fluids |
|---------------------------------|---------------|
| Glyceryl octanoate (C8) | 0.07 |
| Glyceryl decanoate (C10) | 0.06 |
| Glyceryl laurate (C12) | 0.08 |
| Glyceryl monooleate (C18.1)* | 0.04 |
| Polyethyleneglycol 400 dioleate | 0.18 |
| Without Lubricant | 0.23 |

* The glyceryl oleate evaluated as lubricants was the one with 74% of monoglyceride.

Table 3.1. Coefficient of Friction (COF) of the formulated water based fluids with different lubricants

Since the hydrophilic segment of the four evaluated glyceryl esters is the same, it would be expected that the efficiency of the products would increase together with the length of the hydrophobic segment, but this effect was not observed. As observed in Table 3.1, the additive that presented the best performance as lubricant in aqueous media was glyceryl oleate (C18.1), but no significant difference between the other glyceryl esters was observed. This behavior can be mainly attributed to the hydrophobic chain's length and to the additive's physical state. As glyceryl laurates (C12) and glyceryl decanoates (C10) are solid at room temperature, their dispersion is difficult, even with vigorous agitation of the Hamilton Beach shaker, resulting in a less effective performance. On the other hand, C8 and C18:1 are liquid at room temperature, which enables them to disperse easily within the media, and consequently cover the metal surface. The better results obtained by the oleates (C18:1) can be attributed to its longer hydrophobic segment, which leads to easier sliding between the covered surfaces. It is interesting to observe the role of the *cis* -insaturation

present in the structure of the C18.1 molecule on its potential as a lubricant. This configuration is responsible for the ester's physical state in opposition to the trans isomer, glyceryl elaidate, which is a solid. In the case of the commercial lubricant, polyethyleneglycol 400 dioleate, even considering that it is liquid and presents the same hydrophobic chain as glyceryl monooleate, it does not have hydroxyls on the polar segment of its structure, which is a key structural parameter to promote the adsorption on the surface and consequently potential activity as lubricant.

3.1.2 Glyceryl esters as emulsifiers for oil based drilling fluids

Table 3.2 shows the electrical stability (ES) values obtained with the different formulations of paraffin based drilling fluids. In this study, the content of the glyceryl monooleate in relation to the dioleate was evaluated, as well as the nature of the emulsifier. It is observed that the commercial emulsifier sorbitan monooleate led to a lower ES value, while the synthesized glyceryl esters showed better results. In addition, the higher the amount of glyceryl monooleate in the composition of the oleic glyceride, the higher was the electrical stability presented by the fluid.

| Emulsifier | % of monoderivative in emulsifiers | ES (Volts) |
|----------------------------|------------------------------------|------------|
| Sorbitan monooleate | - | 489 |
| Glyceryl laurate | - | 593 |
| Commercial Glyceryl oleate | 50 | 484 |
| Glyceryl oleate | 60 | 638 |
| Glyceryl oleate | 74 | 746 |

Table 3.2. Electrical stability (ES) values of oil based drilling fluids formulated with different emulsifiers.

For a molecule to perform as an emulsifier it requires a specific structure where it presents a hydrophilic and a hydrophobic segment. Depending on the nature and the length of these segments, the molecule can promote a direct emulsion (oil-in-water) or an inverted emulsion (water-in-oil). Surfactants in which a hydrophilic nature predominates tends to form direct emulsions, while the predominantly lipophilic surfactants usually form inverted emulsions. The Hydrophilic-Lipophilic-Balance (HLB) is a key parameter that guides the choice of the appropriate surfactant to the target application. A high HLB surfactant is predominantly hydrophilic, whereas a low HLB surfactant is lipophilic in nature.

As sorbitan monooleate is used as an emulsifier in inverted emulsions, due to its low HLB, its performance was compared to that of synthesized glyceryl esters. When comparing the structures of glyceryl monooleate with sorbitan monooleate it is observed that they have the same hydrophobic segments, but different hydrophilic segments. The ES results show that the glyceryl segment led to better emulsion stability. That is probably due to the fact that the glyceryl segment is less polar than the sorbitan segment, leading to a lower HLB, what would favour the emulsification in this case. Glycerin monolaurate showed a good performance even presenting a shorter lipophilic segment, suggesting that the nature of the

hydrophilic segment is in fact the key parameter. As discussed in previous sections, the selectivity of monoglycerides syntheses has to be optimized. When comparing the performance of products obtained in the esterification of glycerin with oleic acid where different monoderivatives yields were formed, we observe that better results were reached with systems that contained a higher amount of glyceryl monooleate and less glyceryl dioleate. This may suggest that the disubstituted product is excessively lipophilic, presenting a high affinity with the oil phase, which makes it migrate to this phase, instead of retaining it in the interface, and so minimizing its performance as an emulsifier of oil based fluid.

3.1.3 Glyceryl ester as an anti-crystallizing agent for ester based drilling fluids

The methyl esters of fatty acids (FAME) used as fluid base presented crystallization temperatures (T_c), at the present experimental conditions, at -6.4°C while by the addition of glyceryl oleate this temperature went down to -8.4°C . The effect of esters-additives prepared with monoalcohols and acids with up to 12 carbon atoms on the T_c of methyl fatty acid esters from soybean oil has already been registered to be able to decrease its T_c down to -7.6°C [Nascimento et al, 2005; Soares et al, 2009]. These same authors observed similar results for the ester-additives from di- and trihydroxylated alcohols other than glycerol. However the glyceryl oleate was able to decrease further the T_c of these methyl esters. Even more relevant was the data obtained for the induction time for crystallization as observed by the naked eye. A two fold increase in the induction time was observed for the FAME base fluid. The FAME crystallized after 30 minutes at -4°C without additive and upon its addition it delayed 50 minutes to start crystallization.

3.2 The ketal-glyceryl ester as fuel additive

The mixtures of biodiesel (B100) and the proposed additives (mixtures BDM65 and BDM25) were evaluated in relation to critical fuels thermal properties. The properties discussed are: the temperature of crystallization, the oxidation behaviour and the distillation range.

3.2.1 Temperature of crystallization

Temperature of crystallization (T_c) is one of the most critical properties of a biodiesel for, as crystallization starts, the viscosity increases leading to a higher pour point. In biodiesel this behaviour depends on the composition of methyl esters, specifically, on the percentages of methyl esters of stearic and palmitic acids [Knothe, 2005]. These are both solids at ambient temperature, and precipitate or form a gel, when their solutions are cooled, as it happens in biodiesel [Nascimento et al, 2005]. The calorimetric analysis (DSC) of biodiesel (B100) showed a crystallization onset at -6.9°C with two peak maxima at about -7.7°C and -15°C , which is typical of soybean-methyl-biodiesel at the present DSC experimental conditions. The products BDM65 and BDM25 presented a similar qualitative behaviour, but with less intense peaks, that means a smaller variation of enthalpy per gram, and a small increase in T_c . These data are shown in Table 3.3 for BDM65, which is the product containing the highest amount of ketal-glyceryl-ester. A higher crystallization temperature would be expected for the products containing ketal-glyceryl-esters, because of their greater average molecular mass. Corroborating with this expectation, the (2,2-dimethyl-1,3-dioxolan-4-yl) methyl palmitate (PDM), prepared in this work, presented a higher melting point (66°C) than methyl palmitate (30°C) and crystallized at 51°C . However, the palmitate derivative is

not the main component in these mixtures but the ketal-glyceryl esters prepared have a high contribution of unsaturated chain fatty acids as is common in biodiesel esters. This could explain the small effect of these additives on the Tc of the final mixture containing as much as 65% of ketal-glyceryl esters.

3.2.2 Oxidative stability of BDM Products

Another important characteristic to be considered in a soybean oil derived biofuel is its oxidative stability during storage. The process of oxidation of soybean oil or of its methyl esters, by the action of atmospheric oxygen, starts at the allyl carbon present in the chains of oleate, linoleate and linolenate, which constitute about 80% of soybean oil biodiesel. Hydroperoxides formed at the initiation step can either react with other radicals, resulting in high molecular weight insoluble sediments and gums, or break apart to form carboxylic acids [McCormick et al, 2007]. In the present study this process would be of a concern because unsaturated chains are present. By differential scanning calorimetry (DSC), the product BDM65 presented oxidation onset at 143°C, BDM25 presented it at 127°C while B100 presented it at 128°C. This is a significant result indicating that the glycerol part of the structure did not enhance the oxidation process. Its presence in a higher amount, as in BDM65, seemed to work in the opposite direction helping to delay oxidation, while a smaller amount, as in BDM25 did not change the oxidative behaviour of B100.

| Temperature of distillation (°C) | | | |
|----------------------------------|-------|-------|-------|
| Distilled | | | |
| Volume | 10% | 50% | 90% |
| B100 | 188.6 | 192.9 | 357.9 |
| BDM25 | 199 | 214.8 | 356.8 |

Table 3.3. Thermal properties of BDM mixtures containing biodiesel and ketal-glyceryl esters in different proportions measured by DSC.

3.3.3 Distillation range of BDM products

The distillation curve gives a pattern of the volatility of the components providing important information. The boiling range is directly related to viscosity, vapor pressure, heating value, average molecular weight, and many other chemical, physical, and mechanical properties. Any of these properties can be the determining factor in the suitability of the product in its intended application. Petroleum product specifications often include distillation limits based on data by the ASTM D1160.

This test method covers the determination, at reduced pressures, of the range of boiling points for petroleum products that can be partially or completely vaporized at a maximum liquid temperature of 400°C. In the case of diesel, the distillation curve following ASTM 1160 is used to determine the cetane index by applying the distillation data to ASTM D4737. According to the Brazilian agency for fuel regulation (ANP), 90% of biodiesel B100 must distillate below 360°C. Table 1 gives the temperature of distillation determined by ASTM 1160 for a biodiesel (B100) and BDM25 at 10, 50 and 90% volume cuts as established by the referred method. The product BDM25 and B100 were inside the 90% limit, while a smaller percentage of BDM65 (87%) distilled below 360°C.

| Temperature of distillation (°C) | | | |
|----------------------------------|-------|-------|-------|
| Distilled Volume | 10% | 50% | 90% |
| B100 | 188,6 | 192,9 | 357,9 |
| BDM25 | 199 | 214,8 | 356,8 |

Table 3.4. Distillation behaviour of biodiesel and BDM25, following ASTM 1160

These results showed that (2,2-dimethyl-1,3-dioxolan-4-yl)-methyl esters contributed to an increase in the final temperature of distillation, but that a maximum amount of 25% can be added to biodiesel in order to maintain its volatilization performance.

If the BDM mixtures are diluted in diesel, for example mixed with B20, which is a diesel containing 20% biodiesel, these properties will also be diluted and will not affect the studied biodiesel thermal behaviour. It will be necessary, though, to test its performance under a higher amount of oxygen for longer times as they occur in the combustion chambers of compression ignition engines to investigate gum formation. This is a known problem detected in biodiesels that contain a certain amount of glycerol and partial glycerides.

4. Conclusions

Glyceryl oleates containing a minimum of 74% of monoglyceryl oleates have shown great potential for application as lubricants for water based fluids and as emulsifiers in oil based fluids, leading to excellent results, when compared to the commercially available additives. In addition, they are environmentally friendly and low cost, since they may be obtained from an abundant raw material which is the glycerin by product of biodiesel production.

The evaluation of the thermal properties of mixtures of biodiesel and the ketal-glyceryl esters allows one to say that the substitution of methyl alcohol by a glycerol derivative in the structure of fatty esters has resulted in a product that is not detrimental to some critical biodiesel properties. The conversion of such a glycerol derivative into a product to be added to biodiesel could be a solution to the problem of utilising the excess of co-product glycerol. However it is not a "ready to use" product as some modifications must be made to compression ignition engines to avoid gum formation from the glycerol moiety.

5. Future research

Improvement in the synthesis of monoesters of glycerol must be focused on reaching higher selectivity in this product. It would be useful to have pure compounds to precisely establish the role of monoesters structures of polyhydroxylated alcohols as emulsifiers, lubricants and anti-crystallizing agents.

6. References

- About-Rachid, H., Bonneviot, L., Xu, G. & Kaliaguine, S. (2003). On the correlation between kinetic rate constants in the autoignition process of some oxygenates and their cetane number: a quantum chemical study. *J Mol Struct*, Vol. 3, (February 2003) 293-304, ISSN: 0166-1280
- Abro, S.; Pouilloux, Y.; Barroult, J. Selective synthesis of monoglycerides from glycerol and oleic acid in the presence of solid catalysts. *Stud. Surf. Sci. Catal*, Vol. 108, (1997) 539-546, ISSN 0167-2991

- Albinante, S. R.(2007) Aditivos Inibidores de Cristalização para Fluidos de Perfuração de Base Orgânica Sintética para Poços de Petróleo em Águas Profundas. MSc Thesis, Instituto de Química, Universidade Federal do Rio de Janeiro.
- Al-Sabagh, A.M.; Noor El-Din, M.R.& Mohamed, H.M. (2009). Oil Base Mud. Part I: Synthesis of some local surfactants used as primary emulsifiers for oil base mud and evaluation of their rheology properties. *Journal of Dispersion Science and Technology*, Vol 30, 1079-1090, 2009.
- ASTM Standard D-1160 (2006). Standard Test Method for Distillation of Petroleum Products at Reduced Pressure", ASTM International, West Conshohocken, PA, 2006, DOI:10.1520/D1160-06, www.astm.org
- ASTM Standard D-4737 (2009). Standard Test Method for Calculated Cetane Index by Four Variable Equation" ASTM International, West Conshohocken, PA, 2009, DOI:10.1520/D4737-09A, www.astm.org
- Batista, L.N. (2008) Desenvolvimento de um biocombustível a partir de glycerol. MSC Thesis. Instituto de Química, Universidade Federal do Rio de Janeiro (May 2008).
- Behr, A; Eilting, J.; Irawadi, K.; Leschinski, J. & Lindner, F.(2008) Improved utilisation of renewable resources: New important derivatives of glycerol. *Green Chem*, Vol 10, No. 1 (January 2008) 1-140
- Bell, B.M.; Briggs, J.R.; Campbell, R.M.; Chambers, S.M.; Gaareestroom, P.D.; Hippler, J.G.; Hook, B.D.; Kearns, K.; Kenney, J.M.; Kruper, W.J.; Schreck, D.J.; Theriault, C.N.; Wolfe, C.P. (2008). Glycerin as a renewable feedstock for epichlorohydrin production. The GTE process. *Clean*, Vol 36, No.8, 657.
- Bogalhos, P.; Fregolente, L.; Pinto, G.M.F.; Wolf-Maciél, M.R.; Maciel, R. (2010) Monoglyceride and Diglyceride Production Through Lipase-Catalyzed Glycerolysis and Molecular Distillation. *Appl. Biochem. Biotech* Vol 160, No.7, (April 2010) 1879-1887
- Boot, M.; Frijters, P.; Luijten, C.; Somers, B; Baert, R.; Donkerbroek, A; Klein-Douwel, R.J.H & Dam, N.(2009) . Cyclic Oxygenates: A New Class of Second-Generation Biofuels for Diesel Engines. *Energy & Fuels*, Vol.23, 1808-1817 (2009)
- Centi, G. & van Santen, R.A. (2007). Catalysis for renewable: from feedstock to energy production, Wiley-VCH, Weinheim, 2007. ISBN: 978-3-527-31788-2
- Chevernet, M.E.; Pernot, V. (1998) Control of Shale Swelling Pressures Using Inhibitive Water-base Muds. SPE Paper 49263, presented at 1998 SPE Annual Technical Conference and Exhibition, New Orleans, LA (1998).
- Ciapina, E.M.P.; Melo, W.C.; Santa Anna, L.M.M.; Santos, A.S.; Freire, D.M.G.; Pereira, N. (2006). Biosurfactant production by *Rhodococcus erythropolis* grown on glycerol as sole carbon source. *Appl. Biochem & Biotechnol.*, Vol. 131, No. 1-3 (March, 2006) 880-886.
- Corma, A., Iborra, S., Chornet, A.I.L Velly, S. Bee Abd Hamid,. Preparación de monoésteres de ácidos grasos. Universidad Politécnica de Valencia, ES 2 229 948, 14 October 2003, 1 June 2006
- CPS Biofuels (2010). Site of the company www.cpspowershot.com Access in September 2010.
- da Silva-Machado, M.; Pérez-Pariente, J. ; Sastre, E.; Cardoso, D.; Martínez-Guerenu, A. Selective synthesis of glycerol monolaurate with zeolitic molecular sieves . *Appl. Catal. A*, Vol 203, No. 2, (October, 2000) 321-28. ISSN: 0926-860X.
- Da Silva, M.A.M.; Medeiros, V.C.; Langone, M.A.P.; Freire, D.M.G. (2003) Synthesis of monocaprin catalyzed by lipase. *App Biochem & Biotechnol*, Vol 105, (April 2003) 757-768.

- Dasari, M.; Kiatsimkul, P.; Suterlin, W.; Suppes, G.J. (2005). Low-pressure hydrogenolysis of glycerol to propylene glycol, *Appl.Catal.A*, Vol.281, No.1-2, (March, 2005), 225 -231, ISSN: 0926-860X.
- Delfort, B.; Durand, I.; Jaecker, A.; Lacombe, T.; Montagne, X. & Paille, F. (2005) Fuel compounds containing glycerol acetals patent: US6890364 (May 2005)
- Diaz, I.; Mohino, F.; Pérez-Pariente, J. ; Sastre, E. (2001) Synthesis, characterization and catalytic activity of MCM-41-type mesoporous silicas functionalized with sulfonic acid. *Appl. Catal. A: Gen.*, 205, 1-2, (January, 2001) 19-30, ISSN: 0926-860X.
- Diaz, I.; Mohino, F.; Pérez-Pariente, J.; Sastre, E. (2003) Synthesis of MCM-41 materials functionalised with dialkylsilane groups and their catalytic activity in the esterification of glycerol with fatty acids. *Appl. Catal. A:Gen.*, Vol 242, No.1, (March, 2003) 161-169. ISSN: 0926-860X.
- Diaz, I.; Mohino, F.; Blasco, T.; Sastre, E.; Pérez-Pariente, J. (2005) Influence of the alkyl chain length of HSO₃-R-MCM-41 on the esterification of glycerol with fatty acids. *Microporous and Mesoporous Materials*, Vol. 80, No.1-3, (May, 2005) 33-42, ISSN: 1387-1811.
- Dubois, J. L., Iborra-Chornet, S., Canos, A. C. & Velty, A. I. (2009). Diesel Fuel containing long chain glycerol acetals. EP application May 2008; patent: WO08050030/EP209482, sep. 2009.
- Fink, J. K. (2003). Oil Field Chemicals. Gulf Publishing Company, First Edition, New York, 2003, ISBN: 0-7506-7703-1.
- Freitas, L.; Paula, A.V.; dos Santos, J.C.; Zanin, G.M.; de Castro, H.F. (2010). Enzymatic synthesis of monoglycerides by esterification reaction using *Penicillium camembertii* lipase immobilized on epoxy SiO₂-PVA composite. *J. Molec Catal B-enzimatic*, Vol.65, No 1-4 (August 2010) 87-90.
- Garcia, E.; Laca,M.;Perez,E.; Garrido, A.; & Peinado, J. (2008). New class of acetal derived from Glycerin as a biodiesel fuel component. *Energy& Fuel*, Vol. 22, No.6, 4274-4280.
- Gupta, V.P. (1995). Glycerine Diteritary Butyl Ether Preparation. Publication date: December 1995. Patent No.US5476971.
- Guner, F.S.; Yager, Y. & Erciyas, A.T. (2006) Polymers from triglyceride oils. *Prog Polym Sci*, Vol.31, (July 2006) 633-670.
- Hale, A.H., Dewan, A.K.R. (1989). Inhibition of Gas Hydrates in Deepwater Drilling. SPE/IADC Paper 18638, presented at the SPE/IADC 1989 Drilling Conference, New Orleans, LA (1989)
- Hillion, G.; Delford. B. & Durand. I. (2005). Method for producing biofuels, transforming triglycerides into at least two biofuel families: fatty acid monoesters and ethers and/ or soluble glycerol acetals. WO 2005/093015 A1
- Jerome, F; Pouilloux, Y.; Barrault, J. (2008). Rational Design of Solid Catalysts for the Selective Use of Glycerol as a Natural Organic Building Block. *ChemSusChem*, Vol.1, No. 7, (July, 2008) 586 - 613, ISSN:1864-564X.
- Karam, A.; Gu, Y.; Jerome, .F.; Douillez, J.P.; Barrault, J. (2007) Significant enhancement on selectivity in silica supported sulfonic acids catalyzed reactions. *Chem Commun.*, 22, (2007), 2222-2224, ISSN: 1359-7345.
- Kirk, R.E. & Othmer, D.F. (1951) Encyclopedia of Chemical Technology. Vol7, Interscience Pub. New York, 216-228
- Knothe G.(2005). Dependence of biofuel fuel properties on the structure of fatty acid alkyl esters. *Fuel Process Technol* ; Vol.86, No.10, 1059-70, ISSN: 0378-3820
- Klepacova, K., Mravec, D. & Bajus, M. (2006). Etherification of glycerol with tert-Butyl Alcohol Catalysed by ion-Exchange Resins. *Chem Papers*, Vol 60, (2006) 224

- Marrouni, K. E., Abou-Rachid, H. and Kaliaguine, S. (2008), Theoretical study of ignition reactions of linear symmetrical monoethers as potential diesel fuel additives: DFT calculations. *International Journal of Quantum Chemistry*, Vol.108, No 1,40-50 (2008).
- Maker, D & Muller, H (2009) Lubricants for drilling fluids. European Patent application, jun 2001, EP 2201082
- Márquez-Alvarez, C.; Sastre, E.;& Pérez-Pariente, J. (2004) Solid Catalysts for the Synthesis of Fatty Esters of Glycerol, Polyglycerols and Sorbitol from Renewable Resources. *Top. Catal*,Vol.27, No.1-4, (February, 2004) 105-117, ISSN: 1022-5528.
- McCormick, R.;L.; Ratcliff, M.; Moens, L. & Lawrence, R. (2007). Several factors affecting the stability of biodiesel in standard accelerated tests. *Fuel Process Technol*, Vol.88, No.7, (July 2007) 651-7, ISSN: 0378-3820.
- Melero, J. A.; Vicente, G; Morales, G.; Paniagua, M. & Bustamante, J. (2010) Oxynated Compounds derived from glycerol for biodiesel formulation:influence on EM 14214 quality parameters. *Fuel*, Vol. 89, No.8, (August 2010) 2011-2018.
- Miller, D. J.; Peereboom, L.; Kolah, A. K.; Asthana, N. S. & Lira, C. T. (2008). Process for production of composition useful as a fuel. Patente US7321052B (January 2008).
- Mueller, H., Claus-Peter, H / Bongardt, F.; Herzog, N. & von Tapavicza, S. (2004). Lubricants for drilling fluids. US Patent 6806235, (October 2004).
- Nandi, S.; Gangopadhyay, S.; Ghosh, S. (2008).Lipase Catalyzed Synthesis of Neutral Glycerides Rich in Micronutrients from Rice Bran Oil Fatty Acid Distillate . *Journal of Oleo Science*, 57, 11, 599-603. ISSN 1345-8957.
- Nascimento, R.S.V., Soares, V.L.P., Albinante, S.R.& Barreto, L.R. (2005). Effect of ester-additives on the crystallization temperature of methyl hexadecanoate. *J Therm Anal Calorim.*,Vol. 79, No.2, (January 2005) 249-54, ISSN: 1388-6150.
- Nouredini, H. (2001). System and Process for producing biodiesel fuel with reduced viscosity and a cloud point below thirty two degrees Fahrenheit. US Patent 6174,501 (2001).
- Pagliaro, M & Rossi, M. (2008). The Future of Glycerol. RSC Publishing, London, ISBN: 978-0-85404-124-4.
- Pomerleau, D.G.; "Glycerol Based Drilling Fluids", US Patent Application 20090143254, 2009.
- Pouilloux, Y.; Abro, S.; Vanhove, C.; Barraoult, J. (1999). Reaction of glycerol with fatty acids in the presence of ion-exchange resins: Preparation of monoglycerides. *J. Mol. Catal.*, 149, 1-3 (December, 1999) 243- 54, ISSN: 1381-1169.
- Puche, J. D. (2003). Procedure to obtain biodiesel fuel with improved properties at low temperature. Publication date: November 2003. Patent No. 20030167681.
- Rahmat, N., Abdullah, A.Z. & Mohamed, A.R. (2010). Recent progress on innovative and potential technologies for glycerol transformation into fuel additives: A critical review. *Renewable and Sustainable Eenergy Reviews*, Vol 14, No 3 (April 2010) 987-1000.
- Sakthivel, A.; Nakumara, R.; Komura, K. & Sugi, Y. (2007). Esterification of glycerol by lauric acid over aluminium and zirconium containing mesoporous molecular sieves in supercritical carbon dioxide medium *J. of Supercritical Fluids* 42, 2, (2007) 219-25, ISSN: 0896-8446.
- Santa Anna, L.M.S.; Sebastian, G.V.; Pereira, N. ; Alves, T.L.M.; Menezes, E.P.& Freire, D.M.G. Production of biosurfactant from a new and promising strain of *Pseudomonas aeruginosa* PA1. *Appl. BioChem & Biothechnol*, Vol. 91, No.3, (April, 2001) 459-467
- Shelley, S. (2007). A Renewable Route to Propylene Glycol. *Chem. Eng. Prog.*, 2007, Vol.103, No. 8 (August 2010) 6. <http://www.senergychem.com>, accessed in August 2010.

- Shreve, R.N. & Brink, J.A. (1977) *Chemical Process Industries*, 4th ed., Mc Graw-Hill, New York.
- Siano, D.; Santacesaria, E.; Fiandra, V.; Tesser, R.; Nuzzi, G.Di; DiSerio, M.; Natasi, M. (2006). Process for the production of alpha, gamma-dichlorohydrin from glycerin and hydrochloric acid. Publication date: October 2006. Pub No.WO2006111810.
- Simonetti, D.A., Rass-Hansen, J., Kunkes, E.L., Soares, R.R. & Dumesic, J.A. (2007). Coupling of Glycerol Processing with Fisher-Tropsch synthesis for production of liquid fuels. *Green Chem.*, Vol 9, No.10, 1073-1083, ISSN:1463-9262
- Simova, S.; Ivanova, G.; Spassov, S.L. (2003). Alternative method for quantitative determination of acyl positional distributions in triacylglycerols and related compounds. *Chem. Phys. Lipids*, 126, 2, (2003),167-176, ISSN: 0009-3084
- Soares, R.R.; Simonetti, D.A.; Dumesic, J.A. (2006) Glycerol as a source for fuels and chemicals by low-temperature catalytic processing. *Angew. Chem. Int. Ed.*, 45, 24, (2006), 3982-3985, ISSN: 1433-7851.
- Soares, V.L.P, Albinante, S.R. & Nascimento, R.S.V. (2009) Ester-additives as inhibitors of the solidification of soybean oil methyl esters. *J Therm Anal Calorim*, Vol 97, No.2 (November 2009) ISSN 1382-6150.
- Sofiproteol (2007). www.fas.usda.gov/gainfiles/200702/146280213.pdf
- Song, J.; Zello, V. & Boehman, J. (2005). Comparison of the Impact of Intake Oxygen Enrichment and Fuel Oxygenation on Diesel Combustion and Emissions. *Energy & Fuels*, Vol 19, 403-410 (2005)
- Spooner- Wyman, J.K. & Appleby, D.B.(2005). Fuel composition for producing heat and power., Patent US2005000150-A1; WO2005003264-A1; EP1641901-A1
- Sunder, A.; Hanselmann, R.; Frey, H.; Mulhaupt, R. (1999) Controlled synthesis of hyperbranched polyglycerols by ring-opening multi-branching polymerization. *Macromolecules*, Vol.199, No.32, 4240.
- Sunder, A.; Kramer, M.; Hanselmann, R.; Mulhaupt, R.; Frey, H. (1999). Molecular nanocapsules based on amphiphilic hyperbranched polyglycerols. *Angew. Chem.Int. Ed.* 1999, 38, 3552.
- Suppes, G.J.; Sutterlin, W.R. & Dasar, M.A. (2005). Method for producing lower alcohols from glycerol. WO2005095536.
- Taylor, J.D.; McCormick, R.L. & Murphy, M.J. (2004). Compendium of Experimental Cetane Number Data. National Renewable Energy Laboratory NREL <http://www.nrel.gov/vehiclesandfuels/pdfs/sr368051.pdf>
<http://www.nrel.gov/vehiclesandfuels/pdfs/sr368051.pdf>
- Wang, J.X.; Wu, F.J.; Xiao, J.H. & Shuai, S.J. (2009) Oxygenated blend design and its effects on reducing diesel particulate emissions, *Fuel*, Vol 88 (2009) 2037-2045.
- Watanabe, T; Shimizu, M.; Sugiura, M.; Sato, M.; Kohori, J.; Yamada, N.; Nakashi, K. (2003) Optimization of reaction conditions for the production of DAG using immobilized 1,3-regiospecific lipase lipozyme RM IM. *J. Am. Oil Chem. Soc.*, 2003, 80, 1201.
- Yaakoub, M. C. (2008). Obtenção de aditivos para fluidos de perfuração a partir da glicerina" MSc Thesis, Instituto de Química, Universidade Federal do Rio de Janeiro, March, 2008.
- Yousif, M.H. & Young, D.B. (1993) A Simple Correlation to Predict the Hydrate Point Suppression in Drilling Fluids. SPE/IADC Paper 25705, presented at the SPE/IADC 1993 Drilling Conference, Amsterdam (1993).
- Zhou, C-H; Beltramini, J. N.; Fan, Y-X & Lu, G.Q. (2008). Chemoselective catalytic conversion as a biorenewable source to valuable commodity chemicals. *Chem.Soc. Rev.*, Vol 37 (2008) 527-49, ISSN 0306-0012.

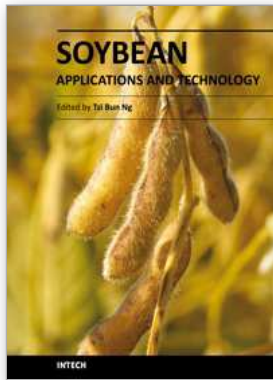

Soybean - Applications and Technology

Edited by Prof. Tzi-Bun Ng

ISBN 978-953-307-207-4

Hard cover, 402 pages

Publisher InTech

Published online 26, April, 2011

Published in print edition April, 2011

Soybean is an agricultural crop of tremendous economic importance. Soybean and food items derived from it form dietary components of numerous people, especially those living in the Orient. The health benefits of soybean have attracted the attention of nutritionists as well as common people.

How to reference

In order to correctly reference this scholarly work, feel free to copy and paste the following:

Vera L. P. Soares, Elizabeth R. Lachter, Jorge de A. Rodrigues Jr, Luciano N. Batista and Regina S. V. Nascimento (2011). New Applications for Soybean Biodiesel Glycerol, Soybean - Applications and Technology, Prof. Tzi-Bun Ng (Ed.), ISBN: 978-953-307-207-4, InTech, Available from:
<http://www.intechopen.com/books/soybean-applications-and-technology/new-applications-for-soybean-biodiesel-glycerol>

INTECH

open science | open minds

InTech Europe

University Campus STeP Ri
Slavka Krautzeka 83/A
51000 Rijeka, Croatia
Phone: +385 (51) 770 447
Fax: +385 (51) 686 166
www.intechopen.com

InTech China

Unit 405, Office Block, Hotel Equatorial Shanghai
No.65, Yan An Road (West), Shanghai, 200040, China
中国上海市延安西路65号上海国际贵都大饭店办公楼405单元
Phone: +86-21-62489820
Fax: +86-21-62489821

© 2011 The Author(s). Licensee IntechOpen. This chapter is distributed under the terms of the [Creative Commons Attribution-NonCommercial-ShareAlike-3.0 License](#), which permits use, distribution and reproduction for non-commercial purposes, provided the original is properly cited and derivative works building on this content are distributed under the same license.

A Ready-To-Use Multi-Target Analytical System for GM Soy and Maize Detection for Enforcement Laboratories

Linda Kluga, Marc Van den Bulcke, Silvia Folloni, Jean-Michel Gineste,
Thomas Weber, Nicoletta Foti, Marco Mazzara,
Guy Van den Eede and Maddalena Querci
*European Commission – Joint Research Centre, Institute for Health and Consumer
Protection (IHCP), Molecular Biology and Genomics Unit,
Via Fermi 2749, 21027 Ispra (Va) -
Italy*

1. Introduction

Today GMO analysis has become an integral part in the development of new genetically modified plants, in subsequent breeding, seed production and verification programmes. GMO analysis is a key technology in export and import of agricultural commodity products, for ascertaining regulatory compliance of GMOs in different countries, for labelling requirements, and for product authenticity and traceability.

In Europe, in particular, GMO analysis is implemented in all Member States to fulfil legal requirements regarding GMOs and GMO-derived products, their release into the environment, cultivation, importation and their utilisation as food, food ingredients and animal feed (European Commission 2001, 2003a, 2003b). A key technical element for the authorisation of GMOs within the EU is the provision of an event-specific quantitative detection method - validated according to internationally accepted standards - to allow the control and monitoring of a particular GMO along the production, processing and the distribution chain.

In this context the European Commission Joint Research Centre (JRC) has the mission to provide scientific and technical support to EU policy development on GMO. The nominated European Union Reference Laboratory for GM Food and Feed (EURL-GMFF) at the JRC is working at the forefront of GMO analysis in Europe. Legally responsible for method validation under Regulation (EC) No 1829/2003 (European Commission 2003a), the EURL-GMFF works in close collaboration with the European Network of GMO Laboratories not only in method validation but also in the harmonisation of a number of topics spanning from sampling to method development, data analysis and measurement of uncertainty. In addition, in Europe, the EURL-GMFF plays a key role in the official food controls according to Regulation (EC) No 882/2004 (European Commission 2004a).

Still, the multi-factorial nature of GMO analysis, the diverse and often complex composition of the samples under examination, the increasing number of GM events and, finally, the

growing need for recognition of mutual analysis and data interpretation require further harmonisation and standardisation at the international level.

Testing needs in Europe, in particular, are constantly growing due to the steady rise of the number of GM events commercialised in various parts of the world (James, 2008). According to the latest ISAAA report (James 2008), 144 GM events, representing 24 crops, have so far received worldwide regulatory approval, and this number is still meant to rise (Stein and Rodríguez-Cerezo 2009).

Different analytical approaches have been developed for GMO identification and quantification: among all alternatives tested, real-time PCR (RTi-PCR) proved to be the most successful, accurate and powerful technique and accordingly, it is now the method of choice for GMO quantification (Miraglia et al. 2004). Due to its intrinsic specificity and to the fact that results are directly extrapolated from the instrument software, avoiding any post-PCR manipulations, RTi-PCR is also increasingly used for qualitative analysis of particular GMOs (Reiting et al. 2007).

The constant increase of different GMO invoked the necessity to screen for GMO presence in a way that post-screening analysis can be limited (James 2008). For this the matrix-approach has been considered most promising and a number of RTi-PCR platforms have been developed and some being used already on real-life samples. Here, we introduce two of these matrix-based approaches in more detail and discuss the possibility of incorporating them in a pre-spotted plate approach.

Finally, harmonisation of GMO analysis will largely depend on the availability of a common decision support system (DSS) to all stakeholders. Here, we will present some of our thoughts on key elements that should be present in such a DSS and discuss how the pre-spotted plate technology could sustain such approach.

2. A ready-to-use multi-target analytical system for GMO detection

Research conducted over the past years in the area of method development, optimisation and validation has provided a wide range of analytical tools already integrated on a routine basis in the GMO monitoring and verification programmes and for the above mentioned steps and applications. However, the conditions of post-marketing monitoring might be very complex.

The European market is not a closed system; as GMOs and derived products originating from non EU countries enter the Union, it can not be excluded that also unknown or GMOs unauthorised in the EU may be introduced and may be present on the EU market for a while before being detected, such as in the cases of Bt10 maize (Commission Decision 2005/317/EC; European Commission 2005a) and LLRICE 601 (Commission Decision 2006/578/EC; European Commission 2006). So far approximately 25 GM events were authorised for food and/or feed use in Europe (http://ec.europa.eu/food/dyna/gm_register/index_en.cfm) while the number of GM events commercialised in other parts of the world is much higher and it is constantly rising (James 2008). This asynchronous approval has resulted in a considerable increase in testing needs to identify authorised and unauthorised GMOs in food and feed samples. All these elements converge, from the practical point of view, on the need of high-throughput systems allowing the rapid and cheap screening of numerous samples for the monitoring and tracing of GMOs in the agricultural food and feed chain. In this context and in collaboration with the European Network of GMO Laboratories (ENGL;

<http://engl.jrc.ec.europa.eu/>) the European Commission JRC has deployed, tested and implemented a high-throughput detection system for the detection of GMOs (Querci et al. 2009) and has designed and explored test strategies that are the basis of a decision-making process to detect GMOs and to distinguish between approved and unapproved GMOs.

A first step was the development of an easy-to-use system for the detection of approved and unapproved GM events and derived food and feed products. The approach represents only one potential analytical alternative and is aimed at developing and providing a fast and handily ready-to-use multi-target system for the detection of (as many as possible) GM events approved and unapproved on the European market in a single experiment.

The selected strategy was formulated and based on a series of considerations summarized below:

1. EURL-GMFF experience and reliability of the data

Over the past years the JRC, through the activities conducted by the Molecular Biology and Genomics (MBG) Unit at the Institute for Health and Consumer Protection (IHCP), has developed a broad expertise in the different analytical aspects involved in qualitative and quantitative GMO analysis. Their recognised leading role in developing, optimising and validating analytical tests for the detection, identification and quantification of GMOs led to the establishment, within the MBG Unit, of the European Union Reference Laboratory for GM Food and Feed (EURL-GMFF) in the context of Regulation (EC) No 1829/2003.

Principal legal duties and tasks of the EURL-GMFF, as defined in Regulation (EC) No 1829/2003, are 1) testing and validation of detection methods for identification of the transformation event in the food or feed and 2) preparation, storage and distribution to national reference laboratories of the appropriate positive and negative control samples.

Detailed rules for the implementation of Regulation (EC) No 1829/2003, and in particular requisites to be followed by applicants when submitting a method of detection to the EURL-GMFF, as specified in Annex I of Regulation (EC) No 641/2004 (European Commission 2004b), include information about the method as such and about the method testing carried out by the applicant and demonstration that the method fulfils, among others, the following requirements:

being event-specific and by definition only recognizing one particular GMO or products derived thereof (and not recognizing any other GMO);

being applicable to food and feed samples and any control samples or reference materials.

Whereas the wide diffusion and adoption of the real-time PCR approach relies on its reliability for DNA quantification, the technique is also more and more frequently used for end-point analysis, for qualitative detection purposes, thanks to its increased intrinsic specificity and to the fact that it allows straight extrapolation of results directly from the instrument software avoiding analysis of PCR products by gel electrophoresis, a step that represents the main risk in terms of laboratory contamination.

2. Incorporation of EURL-validated event-specific methods into the detection platform

The approach followed for the development of the "Ready-To-Use Multi-Target Analytical System for GMO Detection" (Querci et al. 2009) is based on the detection of the different GM events by using event-specific methods. At the time of the start of the project, the EURL-GMFF - as an integral part of the EU approval process - had received for validation 39 dossiers containing molecular data and event-specific methods for the detection of the corresponding individual GM events (without considering 21 dossiers provided for the validation of methods for stacked GM lines) in 7 plant species.

From the methodological point of view, the approach is based on real-time PCR. Indeed, real-time PCR, in addition to the intrinsic specificity mentioned above, has the advantage of being a technique already commonly used in the EU and worldwide and adopted by most if not all (EU) GMO control laboratories. Choosing PCR as a technology guarantees the opportunity of immediate use and integration in the laboratories' working routine, avoiding the acquisition of new instrumentation or the implementation of new procedures and the need for technical formation.

3. A 96-well plate format for easy laboratory implementation

The selected format is in line with the aim to provide a rapid multi-target system (allowing the simultaneous detection of all targets in a single experiment) in a ready-to-use format, therefore reducing to the minimum the laboratory handling steps.

The "Ready-To-Use Multi-Target Analytical System for GMO Detection" has been designed to be delivered in the format of pre-spotted plates containing, in lyophilized format, all primers and probes for the individual detection of all 39 single-insert GM events for which a method was submitted to the EURL-GMFF, and of the corresponding 7 plants species (maize, cotton, rice, oilseed rape, soybean, sugar beet and potato). As shown in Figure 1, to use system the operator just needs to perform few simple steps: extract the DNA from the sample, mix it with the TaqMan® Universal PCR Master Mix (Applied Biosystems), load the mixture on the plate, and start the time temperature programme. Results are then extrapolated directly from the ad-hoc software.

Description of the system and short overview of the performance

Methods incorporated in the system include: event-specific methods for maize Bt11, NK603, GA21 (2 methods), MON863, 1507, T25, 59122, MON810, MIR604, Bt176, MON88017, LY038, 3272, MON89034, Bt10; oilseed rape T45, Ms8, Rf3, GT73, Rf1, Rf2, Ms1, Topas 19/2; cotton MON1445, MON88913, LLCotton25, MON 531, MON15985, 281-24-236 X 3006-210-23; soybean A2704-12, 40-3-2, MON89788, DP-356043; rice LLRICE62, LLRice601, Bt63; sugar beet H7-1; potato EH92-527-1 and a rice P35S::bar specific method; plus target taxon specific methods for the corresponding plant species. As detection of stacked GM lines is based on the use of event-specific methods developed for the parental GM events composing the stack, this system allows the detection of all stacks derived from the 39 single-insert GM events listed above.

Specificity of each of the 48 methods was assessed and confirmed by testing each wild-type plant species and each GM event, individually, against the whole set of methods. Sensitivity of the system was tested by individually loading, in each well, the corresponding wt DNA or GM at different concentrations. Sensitivity of all methods was confirmed to be at least 0.045% expressed as haploid genome equivalents in 100 ng DNA, in line with method specificities and in compliance with EU requirements for method LOD.

For transferability testing, pre-spotted plates were distributed to 31 EU control laboratories together with the blended DNA solution and a negative sample consisting of a 20 ng/ μ L herring sperm DNA solution. Data returned by all laboratories running the system on different platforms (7900HT Real-Time PCR System, 7300/7500 Real-Time PCR Systems, ABI PRISM® 7000/7700 SDS [Applied Biosystems], iCycler iQ Real-Time PCR Detection System [Bio-Rad, Hercules, CA]) showed high levels of reproducibility (EURL-GMFF, unpublished results). Experimental data indicate that this system is adequate for detecting several GM events in a single experiment at 0.045% (expressed in haploid genome copies), thus in full compliance with EU requirements for method performance.

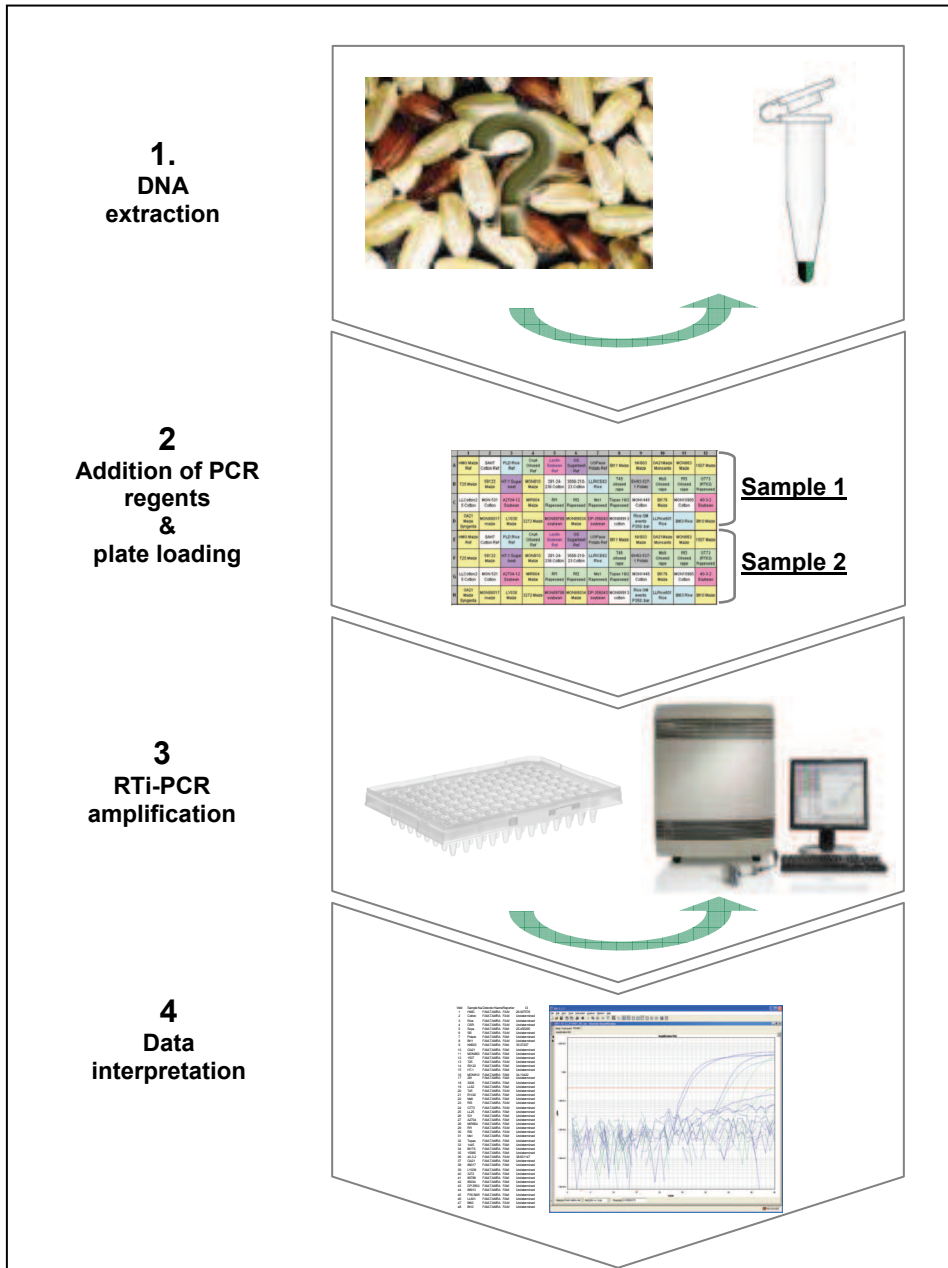

Fig. 1. Four-step workflow for GMO analysis using the ready-to-use multi-target analytical system. 1) DNA is extracted from the sample to be analysed, 2) extracted DNA is added to the PCR master mix and the reaction mix is loaded on the plate, 3) RTi-PCR amplification, and 4) visualisation of the results using the ad-hoc instrument software.

3. Development of a RTi-PCR Ready-to use GM soy and maize detection tool

Considering the importance of GM soy and maize within the global seed commodity market, it was considered that such pre-spotted plates represent a flexible approach *per se* and can be an excellent starting point for a whole new set of applications. Indeed, applying the same principle, a crop-specific formulation was developed for the simultaneous detection and identification of 21 single-insert soybean and maize GM events and a number of stacked events derived from them (Figure 2). This formulation includes the event-specific methods also for 98140 maize, DP-356043 and DP-305423 soybean events, methods submitted for validation to the EURL-GMFF after the 48-method plates described above were formulated. As shown in Figure 2, the layout allows the analysis of 4 samples on a single plate. Also in this case system performance (specificity, efficiency, LOD, etc.) has been successfully confirmed by experimental testing (L. Kluga et al., in preparation).

a)

| well | RTi-PCR method | well | RTi-PCR method |
|------|----------------|------|--------------------|
| A1 | HMG Maize Ref | B1 | LY038 |
| A2 | HMG Maize Ref | B2 | 3272 |
| A3 | Bt11 | B3 | MON89034 |
| A4 | NK603 | B4 | 98140 |
| A5 | GA21 | B5 | Lectin Soybean Ref |
| A6 | MON863 | B6 | Lectin Soybean Ref |
| A7 | DAS1507 | B7 | A2704-12 |
| A8 | T25 | B8 | 40-3-2 |
| A9 | DAS59122 | B9 | MON89788 |
| A10 | MON810 | B10 | DP-356043 |
| A11 | MIR604 | B11 | DP-305423 |
| A12 | MON88017 | B12 | A5547-127 |

b)

| | 1 | 2 | 3 | 4 | 5 | 6 | 7 | 8 | 9 | 10 | 11 | 12 |
|---|---------------|---------------|----------------|-------------|--------------------|--------------------|------------------|----------------|------------------|-------------------|-------------------|-------------------|
| A | HMG Maize Ref | HMG Maize Ref | Bt11 Maize | NK603 Maize | GA21 Maize | MON863 Maize | DAS1507 Maize | T25 Maize | DAS59122 Maize | MON810 Maize | MIR604 Maize | MON88017 Maize |
| B | LY038 Maize | 3272 Maize | MON89034 Maize | 98140 Maize | Lectin Soybean Ref | Lectin Soybean Ref | A2704-12 Soybean | 40-3-2 Soybean | MON89788 Soybean | DP-356043 Soybean | DP-305423 Soybean | A5547-127 Soybean |
| C | HMG Maize Ref | HMG Maize Ref | Bt11 Maize | NK603 Maize | GA21 Maize | MON863 Maize | DAS1507 Maize | T25 Maize | DAS59122 Maize | MON810 Maize | MIR604 Maize | MON88017 Maize |
| D | LY038 Maize | 3272 Maize | MON89034 Maize | 98140 Maize | Lectin Soybean Ref | Lectin Soybean Ref | A2704-12 Soybean | 40-3-2 Soybean | MON89788 Soybean | DP-356043 Soybean | DP-305423 Soybean | A5547-127 Soybean |
| E | HMG Maize Ref | HMG Maize Ref | Bt11 Maize | NK603 Maize | GA21 Maize | MON863 Maize | DAS1507 Maize | T25 Maize | DAS59122 Maize | MON810 Maize | MIR604 Maize | MON88017 Maize |
| F | LY038 Maize | 3272 Maize | MON89034 Maize | 98140 Maize | Lectin Soybean Ref | Lectin Soybean Ref | A2704-12 Soybean | 40-3-2 Soybean | MON89788 Soybean | DP-356043 Soybean | DP-305423 Soybean | A5547-127 Soybean |
| G | HMG Maize Ref | HMG Maize Ref | Bt11 Maize | NK603 Maize | GA21 Maize | MON863 Maize | DAS1507 Maize | T25 Maize | DAS59122 Maize | MON810 Maize | MIR604 Maize | MON88017 Maize |
| H | LY038 Maize | 3272 Maize | MON89034 Maize | 98140 Maize | Lectin Soybean Ref | Lectin Soybean Ref | A2704-12 Soybean | 40-3-2 Soybean | MON89788 Soybean | DP-356043 Soybean | DP-305423 Soybean | A5547-127 Soybean |

Fig. 2. a) List of maize and soybean events detected by the soybean/maize ready-to-use multi-target analytical system and b) Overall plate design wherein the all set of test methods is spotted in quadruple.

This novel plate composition has been successfully applied on highly processed fractions, on low levels of GM targets and on airborne environmental samples (L. Kluga et al., S. Folloni et al., in preparation). The use of this set-up is demonstrated here for three particular legal EU situations (see Figure 3). A mixture of GM soy and maize was prepared to mimic the following situation: low level presence of an asynchronously authorized GM material in a GMO mixture, EU-authorized GM material present as a so-called 'botanical impurity (feed) or contamination (food)', and authorized GM material present at the labelling threshold (0.9%). In all cases, the ready-to-use pre-spotted plates correctly identified the presence of the different GMO present in the sample in a single analysis. In this way, the crop-specific set-up proved to represent a very valuable, cost-efficient tool for complying with the EU enforcement requirements (European Commission 2004a).

| Target | Ct | | | | | | | |
|-----------|----------|-------|-----------------------|-------|----------------------|-------|-------|-------|
| | Labeling | | Asynchr. autorisation | | Botanical impurities | | | |
| | 1 | 2 | 1 | 2 | 1 | 2 | 3 | 4 |
| HMG | | | 24.07 | 24.12 | 23.91 | 25.61 | 26.81 | 23.92 |
| HMG | | | 24.13 | 24.16 | 23.92 | 23.78 | 23.81 | 23.91 |
| Bt11 | | | | | 41.85 | 44.22 | 40.39 | 39.18 |
| NK603 | | | | | | | | |
| GA21 | | | | | | | | |
| MON863 | | | | | | | | |
| DAS1507 | | | 29.23 | 29.31 | | | | |
| T25 | | | | | | | | |
| DAS59122 | | | | | | | | |
| MON810 | | | 28.53 | 28.57 | 38.92 | 39.3 | 40.06 | |
| MIR604 | | | | | | | | |
| MON88017 | | | | | | | | |
| LY038 | | | | | | | | |
| 3272 | | | | | | | | |
| MON89034 | | | | | | | | |
| 98140 | | | | | | | | |
| Lec | 23.1 | 23.01 | 30.71 | 30.77 | 35.28 | 35.5 | 36.51 | 37.55 |
| Lec | 23.15 | 23.09 | 30.64 | 30.81 | 35.47 | 36.63 | 36.28 | |
| A27024-12 | 33.15 | 32.72 | | | | | | |
| 40-3-2 | 29 | 28.84 | 38.67 | 38.94 | 36.24 | 37.2 | 36.81 | 37.86 |
| MON89788 | | | | | | | | |
| DP-356043 | | | | | | | | |
| DP-305423 | | | 32.32 | 32.48 | | | | |
| A5547-127 | | | | | | | | |

Fig. 3. GM soy/maize RTi-PCR ready-to-use PCR analysis (The respective GM materials present were 1) in case of the labelling requirement a mix of wild type soybean DNA supplied with 2% GTS40-3-2 DNA and 0.1% A2704-12 DNA; 2) in the case of the asynchronous authorisation a mix of wild type maize DNA supplied with 20% MON810 maize DNA, 5% TC1507 maize DNA and 0.5% DP-305423 soybean DNA and 3) in the case of botanical impurities WT maize spiked with traces of GTS40-3-2 soybean, Bt11 maize, and MON810 maize (spiking equals 1 GM kernel of each event in 10.000 kernels of wild type maize)

4. Quality assurance for in-house production of RTi-PCR ready-to-use GMO detection plates at the JRC-IHCP

The production of multi-target ready-to-use RTi-PCR plates represents a complex process requiring careful monitoring. The JRC aims at producing the necessary tools for determining the presence of GMO in-house. The foreseen PCR plate production line to support such tools will be managed by a Waters® pipetting robot station. The primers/probes will be purchased from accredited manufacturers. To establish the in-house QC system, it is proposed to apply initially a continuous sampling plan (CSP) approach, meaning that 100% of the produced plates within a single production round will be verified. In a later stage only a limited fraction of the produced plates within one production round will be tested. Hereby the assumption is made that the quality of the production over the lot is sufficiently guaranteed by the validation studies performed on the different sub-steps in the production process. The maximal number of plates verified as a full production would represent the guaranteed accepted number or *clearance number* '1'.

In addition to the clearance number, it is also important to determine the so-called 'Average Outgoing Quality Limit' (AOQL). Any CSP has an AOQL depending on the fraction (designated 'f') of the lot tested and the clearance number *I*. The AOQL represents the maximum or worst possible defect rate or number of defective units for the average outgoing quality. Regardless of the incoming quality, the defect rate or number of defective units going to the customer should be no greater than the AOQL over an extended period of time. Individual lots might be worse than the AOQL but over the long run, the quality will not be worse than the AOQL. The AOQ curve and AOQL assume lots are 100% inspected, and is only applicable to this situation. They also assume the inspection is reasonably effective at removing defective units or defects (90% effective or more).

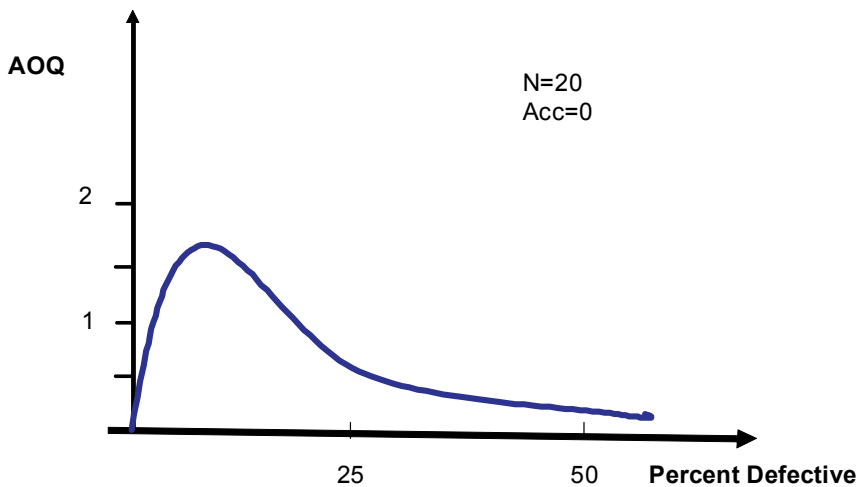

Fig. 4. Exemplary Model for an "Average Outgoing Quality Curve" (Acc = acceptance rate, AOQ indicated as blue line)

The AOQ curve initially increases because when more defective units/defects are produced, more are released. As more and more lots are rejected, 100% inspections become more common and the AOQ curve starts to decrease as a result. The maximum value of the AOQ curve is called the Average Outgoing Quality Level (AOQL) (see figure 4 as an example).

It is the aim to set up a production line guaranteeing the highest acceptable level of accuracy in a lot. To date, a reasonable size of a lot productions at the JRC would be about 20 plates per run (required $I = 20$), representing 20×96 wells = 1920 RTi-PCR analysis. At a 99% AOQL, 19 errors on 20 plates would still be the maximal accepted number of errors, thus one error/plate (calculated as follows: $1920 - (0.99 \times 1920) = 19$). At a 99.5% AOQL, 10 errors would be acceptable, while at a 99.9% AOQL only 2 errors on 20 plates would be accepted. An initial experiment at the JRC with 12 plates demonstrated that no errors occurred at the production line, suggesting that an AOQL close to 99.9% might be technically feasible. In these analyses, considering that the RTi-plates are not uniform but comprise various PCR methods on the same plate, already an estimation of potential cross-contamination during the reagents plate loading by the robot station was assessed. For this, a specific plate set-up was tested wherein 4 different methods were inter-challenged by adding the targets of any of the other methods as

the substrate. No cross-contamination in any of the wells could be determined, demonstrating that the mechanical handling at the robot station is highly accurate.

Taking into account the above findings, the fraction size to be tested, the so-called sampling fraction 'f', can be relatively small. Thus, one full 96-well plate would be tested in cross-challenge modus per lot of 20 plates, wherein any failure at any measurement point would result in the rejection of the entire lot (n=20) for commercial release.

5. Towards a ready-to-use GM soy and maize screening system

Next to event-specific identification, efficient GMO screening approaches are a major request from enforcement laboratories. Screening methods are recognized as useful tools for the rapid and reliable reduction of test samples by direct identification of negative samples, which do not need to be further analyzed. Screening methods are traditionally developed by designing primers targeting the most common sequences used in transformation, and are meant to detect the widest range of GM crops (lines) without requirements of precise identification.

The EC was the world first to validate screening methods for the detection of GMO in raw and processed food samples in the years 1999 and 2000. At that time screening tests, based on the detection of the 35S promoter and the NOS terminator (tNOS) - regulatory sequences globally used in the development of GMO - were considered excellent initial targets to assay irrespective of modification type and, depending on the outcome of the 35S/NOS results, were followed by verification of positives with other rounds of PCR targeting specific transgenic elements or constructs for confirmation and identification purposes.

Over the years the situation varied as new events - containing a wider range of constructs building blocks - were introduced into the market. It is already known that several second-generation biotech products do not have the 35S nor the tNOS sequence. At the present situation in a wide range - globally applicable - screening system the number/type of PCR tests have to be adjusted and include primers also for new constructs elements. In response to the increasing needs in GMO testing, the JRC together with the Scientific Institute of Public Health (IPH, Belgium), a member of the European Network of GMO Laboratories, are developing a ready-to-use tool that includes a wide range of screening methods allowing the detection of any commercial, either approved or unapproved GMO present in the sample. This so-called CoSYPS strategy developed at IPH applies a matrix-based approach which provides guidance on the nature of the GMO present in a product based on the detection of various analytical targets present in commercialized GMOs, both approved and not approved in the EU. The following genetic targets are included today in CoSYPS: Large Subunit of Rubisco gene, Lectin, Alcohol Dehydrogenase, Cruciferin A, CaMV 35S promoter, Agrobacterium Nopaline Synthase terminator, EPSPS-CP4, CryIAb, PAT/pat, PAT/bar (Barbau-Piednoir et al. 2009, Van den Bulcke et al. 2010).

CoSYPS applies SYBR®GREEN real-time PCR methods. SYBR®GREEN is a fluorescent molecule which has a very low fluorescence in the absence of double stranded DNA and a very high fluorescence in the presence of double-stranded DNA. During real-time PCR, SYBR®GREEN binds to any double-stranded DNA which is considered to be advantageous in screening approaches as to extend the detection of closely related targets (Querci et al. 2010). It is expected that the SYBR®GREEN methods will easily be amendable to the pre-spotting technology as in this case only two instead of three oligonucleotides are to be included per assay. The development of ready-to-use CoSYPS screening plates is considered a very complementary tool to the already developed event-specific plates developed at the JRC.

6. Web-based tool for harmonising GMO analysis in Europe

In a final stage, it is envisaged that harmonized GMO analysis will be greatly enhanced when a common decision support system is available and applied. Preferentially, the DSS should consist of a web application for GMO detection and allow for the on-line organisation of a customized GMO-screening setup by applying validated Q-PCR methods and Certified Reference Materials (CRM) within a matrix-based approach.

Such platform would thus be driven by the availability of concise information on validated PCR methods, Certified Reference Materials and a suitable Decision Support System. The central unit within the system could be the Central Core DNA Sequence Information System (CCSIS; <http://mbg.jrc.ec.europa.eu/home/bioinformatics/ccsis.htm>). CCSIS represents the most up-to-date GMO sequence Dbase to date. The data formats of the Dbase are compatible with bioinformatics tools and are accessible to other IT applications. As the key principle in GMO screening analysis is a matrix-based approach, a matrix-generating emulation tool should be incorporated. Such tool should allow to present the target/GMO combinations in a format that allows on the one hand to determine the optimal set of screening methods to be used for a particular application, and on the other hand to provide a means to mathematically 'tag' the GMO that could be present in a sample. The latter has been elegantly demonstrated by the IPH through the use of prime numbers as denominators for each of the screening methods (Van den Bulcke et al. 2010). The former has been developed in a prototype format as the so-called GMOTrack utility that allows defining optimal sets of screening methods based on sample information and a cost function (<http://kt.ijs.si/software/GMOTrack/>).

Both the above modules would feed information for the development of a dual set of complementary pre-spotted plates, one comprising GM-screening elements (the CoSYPS approach), a second one containing the event-specific GMO targets (the ready-to-use-event-specific-pre-spotted plates). The outcome of the analytical results using both sets of plates should then be integrated into an overall decision on GMO presence by transferring all raw data from the PCR devices straight into an analytical result interpretative module. The output of this IT program would indicate which GMO are present (albeit only at qualitative/semi-quantitative levels). In a later stage of development, it may be envisaged to include alarming the user of the presence of unassigned elements in the screening or unauthorized GMO at the event-specific level.

As indicated above, such Decision Support System (DSS) would preferentially be made available through a secure web application managed by a dedicated host server under secure transfer protocols. The need of a common DSS has been already recognized in other GMO research programs (such as the EC 7th Framework CoExtra project; <http://www.coextra.eu/>) and it is considered most valuable to integrate the already developed modules into a common DSS.

7. Conclusions

The 'real-time PCR based ready-to-use multi-target analytical system' developed by the Molecular Biology and Genomics Unit is considered a very suitable approach for the purpose of detection of several GM events in a single experiment. Given the flexible production setup, ready-to-use plates can be a very useful tool for detection of authorised and unauthorised GM events on the Food & Feed market. The selected methodology and format allows a straightforward implementation of the system since real-time PCR using the

96-well plate format is a technique commonly applied in the EU and worldwide. Moreover, the ready-to-use format can be easily extended to other PCR technologies such as SYBR®GREEN, LUX™, or Plexor™. The lyophilized state of the reagents and the primers/probes offers the advantage of long-term storage of the plates for up to one year. In addition, the use of these plates will greatly economize on technical preparation of the PCR analysis and on the storage of all reagents.

The event-specific system was shown already to provide an opportunity to allow testing for all EU-regulated genetically modified plants with minimal experimental handling required. Extending the ready-to-use format to screening applications will also facilitate this part in the GMO analysis. It is considered very advantageous to integrate both the screening and the event-specific analysis into the same platform. As event-specific GMO detection methods are considered the only type of method allowing the univocal identification of a GMO, a concerted interpretation of both screening and identification data is considered essential for accurate interpretations of the experimental results using e.g. differential PCR statistical analysis tools (Cankar et al., 2008).

The usefulness of the pre-spotted plates will largely be defined by the flexibility of production of different formats according to the customers need and the legal environment covered by enforcement measures. The JRC approach described here is shown to be a possible option for such platform and may even be applicable to a broader field than the detection of genetically modified organisms (e.g. pathogens, allergens, tissue-typing, genetic testing...).

Any of the above listed advantages will however be largely dependent on the availability of a common, accurate and updated decision support system (DSS). Such DSS should be based on sound documentation on the GMO, include facilities to develop optimal screening/identification approaches in line with up-to-date information, and allow for interpretation of the analytical results in line with accepted standards. It is considered that a web-based application would herein the most appropriate utility to harmonize GMO analysis throughout the GMO Community.

8. References

- Barbau-Piednoir E, Lievens A, Mbongolo-Mbella G, Roosens N, Sneyers M, Casi AL, Van den Bulcke M (2009) SYBR®Green qPCR screening methods for the presence of “35S promoter” and “NOS terminator” elements in food and feed products. *European Food Research and Technology* 230 (3) p. 383-393
- Cankar K, Chauvensy-Ancel V, Fortabat MN, Gruden K, Kobilinsky A, Zel J, Bertheau Y. (2008) Detection of non-authorized genetically modified organisms using differential quantitative polymerase chain reaction: application to 35S in maize. *Anal Biochem.* 376(2) p. 189-199
- European Commission (1997) Regulation (EC) No 258/97 of the European Parliament and of the Council of 27 January 1997 concerning novel foods and novel food ingredients. *Official Journal L* 043, p. 1-7
- European Commission (2001) Directive 2001/18/EC of the European Parliament and of the Council of 12 March 2001 on the deliberate release into the environment of genetically modified organisms and repealing Council Directive 90/220/EEC. *Official Journal L* 106, p. 1-37

- European Commission (2003a) Regulation (EC) No. 1829/2003 of the European Parliament and of the Council of 22 September 2003 on genetically modified food and feed. Off. J. Eur. Union L 268, p. 1-23
- European Commission (2003b) Regulation (EC) No 1830/2003 of the European Parliament and of the Council of 22 September 2003 concerning the traceability and labelling of genetically modified organisms and the traceability of food and feed products produced from genetically modified organisms and amending Directive 2001/18/EC. Off. J. Eur. Union L 268, p. 24-28
- European Commission (2004a) Regulation (EC) No 882/2004 of the European Parliament and of the Council of 29 April 2004 on official controls performed to ensure the verification of compliance with feed and food law, animal health and animal welfare rules. Off. J. Eur. Union L 191, p. 1-52
- European Commission (2004b) Commission Regulation (EC) No. 641/2004 of 6 April 2004 on detailed rules for the implementation of Regulation (EC) No. 1829/2003 of the European Parliament and of the Council as regards the application for the authorisation of new genetically modified food and feed, the notification of existing products and adventitious or technically unavoidable presence of genetically modified material which has benefited from a favourable risk evaluation. Off. J. Eur. Union L 102, p. 14-25
- European Commission (2005a) Commission Decision of 18 April 2005 on emergency measures regarding the non-authorised genetically modified organism Bt10 in maize products (2005/317/EC). Off. J. Eur. Union L 101, p. 14-16
- European Commission (2005b) Guidance documents on the website of the Community Reference Laboratory (2009) <http://gmo-crl.jrc.ec.europa.eu/guidancedocs.htm>
- European Commission (2006) Commission Decision of 23 August 2006 on emergency measures regarding the non-authorised genetically modified organism LL RICE 601 in rice products (2006/578/EC). Off. J. Eur. Union L 2, p. 308-310
- James C (2008) Global Status of Commercialized Biotech/GM Crops (2008) ISAAA Brief No. 39. ISAAA: Ithaca, NY
- Miraglia M, Berdal KG, Brera C, Corbisier P, Holst-Jensen A, Kok E, Marvin HJP, Schimmel H, Rentsch J, van Rie JP, Zagon J (2004) Detection and traceability of genetically modified organisms in the food production chain. *Food and Chemical Toxicology* 42, p. 1157-1180
- Querci M, Foti N, Bogni A, Kluga L, Broll H, Van den Eede G (2009) Real-time PCR based ready-to-use multi-target analytical system for GMO detection. *Food Analytical Methods* 2, p. 325-336
- Querci M, Van den Bulcke M, Žel J, Van den Eede G, Broll H (2010) New approaches in GMO detection. *Analytical and Bioanalytical Chemistry*, Vol. 396 (6) p. 1991-2002
- Reiting R, Broll H, Weiblinger H, Grohmann L (2007) Collaborative study of a T-nos real-time PCR method for screening of genetically modified organisms in food products. *Journal für Verbraucherschutz und Lebensmittelsicherheit* 2, p. 116-121
- Stein AJ, Rodríguez-Cerezo E (2009) The global pipeline of new GM crops: implications of asynchronous approval for international trade. JRC Technical Report EUR 23486 EN. Office for Official Publications of the European Communities, Luxembourg
- Van den Bulcke M, Lievens A, Barbau-Piednoir E, MbongoloMbella G, Roosens N, Sneyers M, Casi AL. (2010) A theoretical introduction to "combinatory SYBR®Green qPCR screening", a matrix-based approach for the detection of materials derived from genetically modified plants. *Anal Bioanal Chem.* 396(6) p. 2113-2123

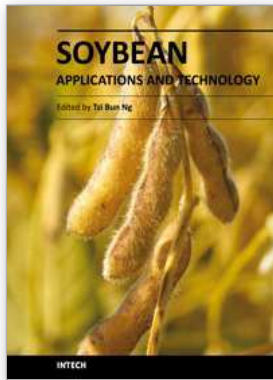

Soybean - Applications and Technology

Edited by Prof. Tzi-Bun Ng

ISBN 978-953-307-207-4

Hard cover, 402 pages

Publisher InTech

Published online 26, April, 2011

Published in print edition April, 2011

Soybean is an agricultural crop of tremendous economic importance. Soybean and food items derived from it form dietary components of numerous people, especially those living in the Orient. The health benefits of soybean have attracted the attention of nutritionists as well as common people.

How to reference

In order to correctly reference this scholarly work, feel free to copy and paste the following:

Linda Kluga, Marc Van den Bulcke, Silvia Folloni, Jean-Michel Gineste, Thomas Weber, Nicoletta Foti, Marco Mazzara, Guy Van den Eede and Maddalena Querci (2011). A Ready-To-Use Multi-Target Analytical System for GM Soy and Maize Detection for Enforcement Laboratories, Soybean - Applications and Technology, Prof. Tzi-Bun Ng (Ed.), ISBN: 978-953-307-207-4, InTech, Available from:
<http://www.intechopen.com/books/soybean-applications-and-technology/a-ready-to-use-multi-target-analytical-system-for-gm-soy-and-maize-detection-for-enforcement-laborat>

INTECH

open science | open minds

InTech Europe

University Campus STeP Ri
Slavka Krautzeka 83/A
51000 Rijeka, Croatia
Phone: +385 (51) 770 447
Fax: +385 (51) 686 166
www.intechopen.com

InTech China

Unit 405, Office Block, Hotel Equatorial Shanghai
No.65, Yan An Road (West), Shanghai, 200040, China
中国上海市延安西路65号上海国际贵都大饭店办公楼405单元
Phone: +86-21-62489820
Fax: +86-21-62489821

© 2011 The Author(s). Licensee IntechOpen. This chapter is distributed under the terms of the [Creative Commons Attribution-NonCommercial-ShareAlike-3.0 License](#), which permits use, distribution and reproduction for non-commercial purposes, provided the original is properly cited and derivative works building on this content are distributed under the same license.

Weed Competition in the Soybean Crop Management in Brazil

Andre Rodrigues dos Reis¹ and Rafael Vivian²

¹*Department of Civil and Environmental Engineering, Waseda University,
169-8555, Shinjuku-ku, Okubo 3-4-1, Tokyo*

²*Brazilian Agricultural Research Corporation - Embrapa Meio Norte - CNPAMN,
Avenida Duque de Caxias 5650, 64006-220 -Teresina - PI*

¹*Japan*

²*Brazil*

1. Introduction

The soybean culture (*Glycine max* (L.) Merrill), driven by the market and especially the selection and development of cultivars widely adapted to its cultivation, has expanded from the southern region to other regions of Brazil, being grown even in the north. In recent years, its importance as an agricultural commodity has a highlighted position among other crops in Brazil. With approximately 58.2 million tons produced on 20.6 million hectares in 2007/08 (FAOSTAT, 2008), the country became the second largest producer and the first in world exports of grains and soy products. The incentive to production is related to the growing global demand for oil and protein for animal feeding and human food, besides the recent feasibility of grain in the production of biodiesel.

Factors like technical expertise and the use of high technological level also contribute to the increase in production and in productivity. The introduction of GM soy, for example, tolerant to glyphosate, has provided several changes related to the cropping system, especially in relation to the weed management in the culture. More recently, EMBRAPA is enabling the introduction of soybeans resistant to the chemical group imidazolinone, as an alternative in the weed management. Tied to these technologies, we highlight some concerns regarding weed control in soybeans, primarily for being bound to just one or two groups of herbicides, exerting a high selection pressure on weed species (Christoffoleti et al, 1994). Furthermore, in the last 30 years, no chemical method allowed the eradication or the complete control of weeds, although they contributed to the increase in the number and to the selection of herbicide-tolerant species (Altieri, 1991).

Despite advances in their controlling, weeds in soy are still a cause of losses in quality and productivity, and the same happens to other crops. This fact contributes to an increased demand for herbicides by the Brazilian market, the most representative of all, with about 40% of pesticides commercialized and among these, 50% dedicated to the soybean production system (Sindag, 2006).

According to estimates made by Oerke & Dehne, (2004), even with the adoption of control measures, Brazil loses the equivalent of U.S\$ 2 billion by the weed competition in soybeans and corn crops. These losses are caused, among others, by the initial coexistence with the

weeds (Meschede et al., 2004) and, mainly, related to variability in the determination of the critical periods of prevention of the interference in soybean. The critical periods, currently defined, are grounded in losses in crop productivity resulting from competition by the weeds, highlighting the most appropriate growth stage for the performing of their control. However, Vidal et al., (2005) questioned this definition by considering that only the biotic components of the culture are observed in the determination of critical periods, without knowing the competitive ability of the weed species. Furthermore, the authors propose that the costs of control and the amount received by the commercialization of grains should be used as criteria for defining the interference periods of the weed. Thus, there is a need to identify the competitive ability of the species, being reported as the main limiting parameter.

1.1 Overview: Weed competition in the soybean crop in Brazil

1.1.1 Weeds and their occurrence in soybeans

Weeds appearance along with agriculture development, about twelve thousand years ago. At that time, with the abundance of species, there was a major balance among the many different plants, each one respecting its genetic inheritance and its habitat to development. With the growth of the population and, consequently, a greater human interference in the proportion and distribution of species, a process of selection of the plants most suited to development in various habitats occurred gradually. Their proliferation and high adaptive capacity have enabled them to be recognized by the human as undesirable in crops, be it due to the reduction in the crop yield, to the losses in the quality of the harvested crop or even to allelopathic effects on successive crops.

Currently, many weeds are widely distributed in the territory, and some species that were typical of the colder regions, such as *Conyza bonariensis*, have been spread in sites of hot and humid tropical climate. Among the species often occurring in soybean crop we can highlight:

Euphorbia heterophylla, which is well-known for its rapid spread and difficulty of control. Its presence is common in places kept under no tillage system (Adegas, 1998) and besides reducing the crop yield, it undermines the system of cleaning and processing the seeds. The losses due to *Euphorbia heterophylla* can reach up to 80% (Kissmann & Groth, 1992), for it presents a high efficiency in water use and higher rates of net photosynthesis than soybean (Procópio et al., 2004). The occurrence of the many biotypes of this species also complicates its management (Vidal & Winkler, 2004), mainly because the chemical control which is effective to a certain place may not be effective to another.

The species *C. bonariensis*, mentioned above, has been one of the major problems faced by products of the various regions of southern and southeastern Brazil. Present in much of the American Continent, *C. bonariensis* and *C. canadensis* are among the species resistant to the herbicide glyphosate (Lamego & Vidal, 2008), complicating its management, especially in the conservation cropping system (Fig 01). These species tend to germinate under optimum soil moisture, especially in no tillage system, not tolerating waterlogged sites. Especially *C. bonariensis* presents greater selectivity to variations in soil moisture (Yamashita & Guimarães, 2010), allowing its germination period to be extended according to local rainfall. Its germination is often concentrated in the coldest period of the year, from May to July. However, the emergence of *C. bonariensis* has been observed during September, October and even in December, when temperatures for the southern hemisphere are extremely high. This allows the plant to develop throughout the year and spread more quickly. Another

advantage of the species is its way of spreading by the wind, allowing only one plant to spread its seeds kilometers away. This fact allied to its high seed production, 110 to 200.000 seeds for *C. bonariensis* and *C. canadensis*, respectively (Wu & Walker, 2004), its presence can reduce the soybean productivity up to 80%. The control of this species is linked, in the practice, to herbicides mixtures, with use of ingredients such as flumioxazin and chlorimuron-ethyl. However, research does not stop and new chemicals are being launched to assist North American and Brazilian producers in managing this species.



Fig. 1. Corn-soybean crop rotation area infested by *Conyza bonariensis* resistant to the herbicide Glyphosate, 2010, Castro / PR, Brazil.

Sourgrass is the common name for the species *Digitaria insularis*, which is one of the most present weeds in the soybean crop, from south to north of the country. Its problem with resistance to glyphosate since 2008 in Brazil has hindered its managing in crops, increasing the affected area. Being a perennial species with broad rhizomatous development, its chemical control becomes difficult after 45 days of growth, when the formation of rhizomes begins (Machado et al. 2006). Due to its rapid growth and photosynthetic efficiency, this species can suppress the development of the crop, limiting the production to less than 20%. Its management boils down to using graminicide in the early stages of the soybean development. However, because of its ineffectiveness when the plant is already perennial, other alternatives such as the crop rotation system are needed, allowing a better control and resistance management for the species (Pereira & Velini, 2003).

Another plant of great adaptability and one of the most difficult to control in the soybean cropping system is *Bidens pilosa*. The species has numerous biotypes scattered in the most disparate regions of the country, favoring the formation of large seed banks (Souza et al., 2009). Its main features are: the extensive formation of achenes, easy dissemination by humans, for it has an efficient system for adherence to surfaces of clothes, bags, and even to

crops such as cotton, besides exhibiting dormancy, which facilitates its viability in soil. *B. pilosa* is also resistant to herbicides which inhibit the acetolactate synthase (ALS - B/2 group), complicating its management in conventional soybeans or even in RR soy (Roundup ready soy), for, in several regions, a single application of glyphosate has not provided satisfactory control of this species. For it shows the highest germination index in the surface layers of the soil, the occurrence of major emergencies of this kind is common in direct sowing, as well as its difficulty to control by glyphosate. The income losses in soybeans caused by the presence of *B. pilosa* are numerous and this is favored by its high efficiency of water use (Aspiazú et al., 2010) in dry regions or regions of prolonged drought stress.

Commelina benghalensis and *Ipomoea grandifolia* are other species commonly occurring in soybeans and offering management difficulties and economic losses. *C. benghalensis*, for example, presents itself as a perennial weed species in tropical regions of Brazil, with seed production in both shoot and root of the plant. Its control requires integrated management of different rotation systems, soil management and chemical treatment. In RR soybeans, its control with a single application of glyphosate is not possible, as well as for the *Ipomoea grandifolia*, which requires sequential sprays or the use herbicides with a different action mechanism. *I. grandifolia*, usually present in corn crops, also infests soybean, and besides the income losses, it impedes the mechanical harvest, making the work in the field difficult. The management of these species has helped to control them. Among the most used, no tillage system in conjunction with the use of crop rotations and cover crops help reduce the occurrence of several species, especially grasses, providing greater sustainability of farming system.

Numerous other not highlighted species are worrying Brazilian soy producers. *Spermacoce latifolia*, *Tridax procumbens* and *Alternanthera tenella*, among others (Tab. 1), are species with high adaptability to different ecological niches throughout the national territory and they are on the list of species likely to be capable of developing resistance to herbicides used in cultivation, being it a GMO or not.

| Scientific name | Common name | Scientific name | Common name |
|--------------------------------|--------------------|-------------------------------|-----------------|
| <i>Acanthospermum hispidum</i> | Starbur | <i>Eragrostis pilosa</i> | Lovegrass |
| <i>Alternanthera tenella</i> | Alligatorweed | <i>Euphorbia heterophylla</i> | Wild Poinsettia |
| <i>Amaranthus retroflexus</i> | Pigweed | <i>Galinsoga parviflora</i> | Smallflower |
| <i>Bidens pilosa</i> | Hairy beggarticks | <i>Ipomoea purpurea</i> | Morningglory |
| <i>Brachiaria plantaginea</i> | Alexandergrass | <i>Panicum maximum</i> | Urochloa maxima |
| <i>Cenchrus echinatus</i> | Sandbur | <i>Pennisetum setosum</i> | Bufflegrass |
| <i>Commelina benghalensis</i> | Dayflower | <i>Portulaca oleracea</i> | Purslane |
| <i>Cynodon dactylon</i> | Bermudagrass | <i>Setaria geniculata</i> | Foxtail |
| <i>Conyza bonariensis</i> | Hairy Fleabane | <i>Sida rhombifolia</i> | Sida |
| <i>Conyza canadensis</i> | Horseweed | <i>Sida spinosa</i> | Sida |
| <i>Digitaria horizontalis</i> | Jamaican crabgrass | <i>Sorghum halepense</i> | Johnsongrass |
| <i>Digitaria sanguinalis</i> | Sourgrass | <i>Spermacoce latifolia</i> | Buttonweed |
| <i>Eleusine indica</i> | Goosegrass | | |

Table 1. Main weed species on soybean Brazilian crop.

The species *Alternanthera tenella*, *Tridax procumbens* and *Digitaria ciliaris* have been now identified as weeds of high occurrence in the Southeast and Midwest, although few details are yet available about its ability to compete. Among the various species occurring in Brazil,

Alternanthera tenella L. (Fig. 2) has emerged as a weed in many agricultural crops (Freitas et al., 2006, Salgado et al., 2007, Petter et al., 2008). Although there are few records, this species causes considerable damage to crops (Nepumoceno et al., 2007), mainly in mechanical harvesting, when its branches and fruits hamper operation and reduce the yield per area. Its occurrence and destruction are mainly related to the cultivation of soybeans in southern, southeastern and central-west Brazil, presenting a high potential to spread and difficulties in its control.

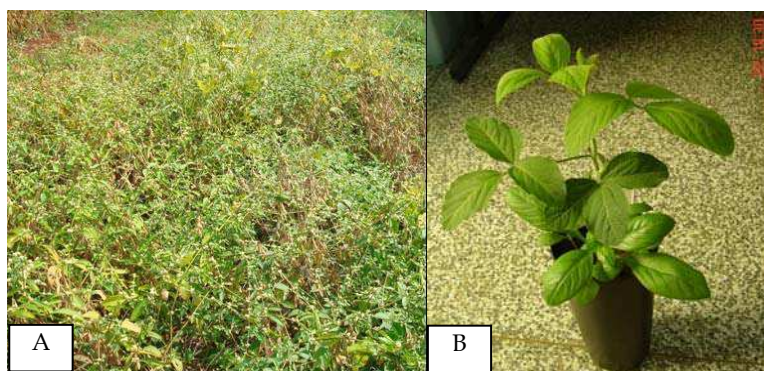

Fig. 2. A) Soybean crop and *Alternanthera tenella* in field; B) Soybean + *Alternanthera tenella* in growth chamber.

1.1.2 Weed management in soybean crops (GM and conventional) in systems of conventional and no tillage

The cultivation of transgenic soybeans in the world and of course also in Brazil increased significantly in the last 5 years. Nowadays, about 73-75% of all soybeans grown in Brazil are GMO (Round-up Ready Soybean) and receives the standard treatment with glyphosate, year after year. The effortlessness of cultivation and profitability are the main arguments for the adoption of this technology. The regions that still remain with non-GM soy are located in the states of Bahia and Parana, mainly. In these locations, the weed management still follows the pattern of pre-emergence application followed by post-emergence herbicides selective to the crop.

Soil management, in turn, is very much associated with the technological system adopted, using annual plowing and disking. Although this system (soil tilling and conventional soybean) represents the minority in Brazilian territory, it still prevails in some places, mainly in the Brazilian cerrado (Savanna). Chemical management in this system is based on the applications of metribuzin, cletodin, trifluralin, etc in pre-emergence, followed by applications of post-emergence herbicides: bentazon, fomesafen, imazethapyr, setoxydin, tepraloxidyne, chlorimuron-ethyl, fluazifop-p-butyl, clorasulan-methyl, etc. After applying the pre-emergence, it is necessary to monitor the area. In many areas, where the weed infestation is small, it is not necessary to use post-emergence or just the use of more specific post-emergence applied in tracks. The use of post-emergence demands some requirements to be effective, including the developmental stage of the weed and the weather conditions during application (humidity and air temperature, wind speed) among others (Buzatti, 1999).

With the emergence of numerous soil losses by erosion and sub-surface leaching it was necessary to adopt a system which would be less aggressive to the physical characteristics of the soil, with preservation of the stubble on the arable layer and maintenance of the soil organic matter. The conversion of areas under conventional planting to no tillage areas and their maintenance for long periods have enabled the recovery in the carbon content of the soil, reaching in some cases, a level above the soil's original level under natural vegetation (Dick et al., 1998). This system also allowed major advances in the practice of sowing, completely altering the lines of Brazilian research in the last 15 years. The microbiology of the soil began to be important in cropping systems and the understanding of integrated production management gained strength.

However, the viability of no tillage system depends on the efficient control of weeds. Thus, one should relate some important aspects of the biology and management of infesting weeds in areas cultivated under this system. A major benefit was the reduction in its germination over time (Perreira et al., 2000) and greater use of the crop control. Moreover, the presence of species not commonly observed in the conventional preparation demand better preparation and expertise of producers. Such modifications are related to the absence of soil disturbance, favoring perennial cycle weeds, as well as changes in patterns of temperature and light incidence, influencing the seed's mechanisms of dormancy.

Several strategies for weed control in no tillage system also require knowledge of population dynamics of the soil's seed bank and must combine integrated methods of control to reduce herbicide use. Generally, the seed bank in no tillage is higher than the one recorded for the conventional system, although the percentage of viable seeds that become competitive with the crop is smaller (Buzatti, 1999). The monitoring of the soil seed bank is crucial in order to evaluate changes in weed community, especially for species with persistent seeds. Among the factors that contribute to the reduction of viability of seed banks in the conservation system we can mention: density and natural aging, changes in soil temperature and soil moisture (Voll et al., 2005), depth of deposition of the seed bank in the soil (Yenish et al., 1992), among others.

Mainly the grasses had their occurrence reduced its occurrence over the years after the adoption of no tillage system, as illustrated (Fig. 02). The system allows greater exposure of the seeds on the soil surface layer, also assists as a physical barrier to germination of positively photoblastic species, as well as enables the reduction of the expression of dormancy mechanisms of species (Vivian et al., 2008), predisposing to faster depletion of the soil seed bank (Carmona & Villas Bôas, 2001).

The remaining straw after desiccation in the no tillage system can also act, through changes in the soil C/N ratio and through the allelopathic action, which prevent or reduce the germination and development of weeds, and even provoke a negative impact on the crop growth. Nevertheless, the activity of allelochemicals in soil is transient and highly complex, as they are also subject to adsorption by soil colloids, degradation, inactivation and transformation by microorganisms (Paes & Rezende, 2001). Among the species with allelopathic action, we can highlight the effects of *Avena strigosa* on grasses (Ruedell, 1995) and *Lolium multiflorum* on *Sida sp.*, *Digitaria horizontalis* and *Brachiaria plantaginea* (Roman, 2002).

Some examples of species with the highest expression, especially in the initial establishment of the sowing reported in southern Brazil are *Bidens pilosa* (Carmona & Villas Bôas, 2001) and *Euphorbia heterophylla*. The absence of soil disturbance favors the concentration of seeds of these species in the surface layer, causing an increased flow of germination in short term,

which requires a further care during the establishment of the system. However, in the long term, its adoption is advantageous for it accelerates the decrease in the seed bank, enabling the uniformity of the seedling emergence and the effectiveness of control measures, especially the chemical.



Fig. 2. A) No tillage system on soybean with application of glyphosate in an area with high seed bank *Brachiaria plantaginea*, in the beginning of soil system adoption - second year of cultivation. B) No tillage system of soybean with application of glyphosate in an area with crop rotation, during the sixth year of cultivation. Ponta Grossa/PR, Brazil.

In other Brazilian regions, such as cerrado and Alto Paranaíba, one can verify a growth of the population of some weeds in the no tillage system, among which we can highlight: *Tridax procumbens*, *Chamaesyce hirta*, *Conyza bonariensis*, *Spermacoce latifolia*, *Alternanthera tenella*, *Leonorus sibiricus*, *Digitaria insularis* and *Cenchrus echinatus* (Paes & Rezende, 2001). Many species also gain ground due to failures of the chemical control, which allow their vegetative tissues to regrowth, even after burn down. Weeds such as *Senecio brasiliensis*, *Brachiaria plantaginea*, *Digitaria horizontalis*, *Richardia brasiliensis* and *Euphorbia heterophylla*, as well as those belonging to the genus *Sida* and *Cyperus* multiply rapidly in the no tillage system rather because of control failures in the crop rotation system than because of the influence of the cropping system (Ruedell, 1995).

The GM soy was one of the great advances in agriculture and contributed to the development of the no tillage system. The system that provides a single application of glyphosate in the early stages of the crop gained market for its ease of adoption, undeniable efficiency in weed control and guarantee of profitability. However, the continuing and disorganized use of the technology, linked to low rotation of cultures resulted in the emergence of herbicide-resistant species, as mentioned earlier. Currently, Brazilian producers are using sequential applications of glyphosate in order to control species which are difficult to manage in crops, such as *Bidens pilosa*, *Ipomoea grandifolia* and *Commelina benghalensis*. Along with glyphosate herbicides, they also associate herbicides of other chemical control groups. Another technique used by producers in southern and

southeastern Brazil is the autumn management, in areas where these species are present. Residual herbicides such as imazethapyr and imazapic are also used to reduce the emergence of weeds during the fallow period and/or associated with the herbicide 2,4-D on burn down, about 15-20 days before the sowing, for the management of dicotyledonous difficult to control by glyphosate. Apart from the variation of biotypes selectivity, the level of herbicide application also contributes to the tolerance of the species. Late applications bring problems of control for the tolerant biotypes, for they hinder the translocation of the herbicide and allow a greater accumulation of reserves in stems, leaves and roots of plants. Both in no tillage and conventional sowing, the current management in soybean aims to integrate cultivation techniques that minimize the effects to the environment and that offer adequate security control. The integrated management provides for connection of all the involved organisms, whether the weeds, pests or diseases should focus on decision-making with case study. There are no more ready-made and generalized solutions without risk of errors.

1.1.3 Weeds resistance and their management in crop

Any suitable chemical management of weeds in any cropping should, besides aiming to achieve the control, include the precautionary principle of a possible emergence of resistance. This means that the attempt to eradicate a species of the area is often extremely dangerous from the point of view of selection of resistant individuals. The occurrence of herbicide-resistant biotypes may include only the active ingredient in question, or be extended to the entire chemical group of control (cross resistance) or to other groups (multiple resistance), such as what occurs to *E. heterophylla*, resistant to ALS inhibitors herbicides, to some herbicides which inhibit protoporphyrinogen oxidase, as well as to glyphosate.

There is yet no evidence to indicate that the herbicides have a mutagenic effect on plants, capable of inducing or creating resistance. The natural genetic variability existent in any population of plants is responsible for the initial source of resistance in a susceptible population of weeds. Thus, all populations of weeds, even those that were not subject to the application of herbicides, are likely to contain individual plants that are resistant to herbicides.

However, the dearth of new mechanisms of action predisposes to repetitive use of herbicides from the same chemical groups of control. In soybean, one of the first herbicides used in the 1970's was the metribuzin, which has the action of inhibition of the electron flow in photosystem II (PS II) of sensitive plants. This herbicide was developed in the 1950's and 1960's and its application to soybean is only made in pre-emergence of weeds (Vidal & Merotto Jr., 2001).

Already in the 1980's, the first selective post-emergence herbicides for soybeans were developed for controlling dicotyledonous. These herbicides act by inhibiting the enzyme protoporphyrinogen oxidase (PROTOX) and are distributed in various commercial products belonging to the chemical groups of diphenylethers, phthalimides and riazolinonae (Vidal & Merotto Jr., 2001). The weed control by these groups occurs particularly in the moment the weeds have between two to six leaves. .

Even in the mid 1980's, the herbicides inhibiting the enzyme acetolactate synthase (ALS) appeared, selective to the crop and with a broader spectrum of action on weeds. Highly efficient products with low dose, these herbicides are still used on a large scale, although they present numerous cases of resistance in Brazil and other countries. In the country,

reports of resistance to herbicides inhibiting ALS were first notified in *Bidens pilosa* in 1993. Since then, the number of reports increased each year. Brazil currently has several reports of species with herbicide resistance, and from these, mainly relate to ALS inhibitors (Table 2).

| Species | Common Name | Year | Herbicide Mode of Action |
|---|--------------------------|------|---|
| <i>Bidens pilosa</i> | Hairy Beggarticks | 1993 | ALS inhibitors |
| <i>Bidens subalternans</i> | Beggarstick subalternans | 1996 | ALS inhibitors |
| <i>Bidens subalternans</i> (Multiple resistance) | Beggarstick subalternans | 2006 | ALS inhibitors Photosystem II inhibitors |
| <i>Brachiaria plantaginea</i> | Alexandergrass | 1997 | ACCCase inhibitors |
| <i>Conyza bonariensis</i> | Hairy Fleabane | 2005 | Glycines |
| <i>Conyza canadensis</i> | Horseweed | 2005 | Glycines |
| <i>Cyperus difformis</i> | Smallflower Umbrella | 2000 | ALS inhibitors |
| <i>Digitaria ciliaris</i> | Southern Crabgrass | 2002 | ACCCase inhibitors |
| <i>Digitaria insularis</i> | Sourgrass | 2008 | Glycines |
| <i>Echinochloa crusgalli</i> | Barnyardgrass | 1999 | Synthetic auxins |
| <i>Echinochloa crusgalli</i> (Multiple resistance) | Barnyardgrass | 2009 | ALS inhibitors Synthetic auxins |
| <i>E. crusgavones</i> | Gulf Cockspur | 1999 | Synthetic auxins |
| <i>Eleusine indica</i> | Goosegrass | 2003 | ACCCase inhibitors |
| <i>Euphorbia heterophylla</i> | Wild Poinsettia | 1992 | ALS inhibitors |
| <i>E. heterophylla</i> (Multiple resistance) | Wild Poinsettia | 2004 | ALS inhibitors PPO inhibitors |
| <i>E. heterophylla</i> (Multiple resistance) | Wild Poinsettia | 2006 | ALS inhibitors Glycines |
| <i>E. heterophylla</i> | Wild Poinsettia | 2007 | ALS inhibitors |
| <i>Fimbristylis miliacea</i> | Globe Fringerush | 2001 | ALS inhibitors |
| <i>Lolium multiflorum</i> | Italian Ryegrass | 2003 | Glycines |
| <i>Oryza sativa</i> | Red Rice | 2006 | ALS inhibitors |
| <i>Parthenium hysterophorus</i> | Raddish | 2001 | ALS inhibitors |
| <i>Sagittaria montevidensis</i> | California Arrowhead | 1999 | ALS inhibitors |

Table 2. Herbicide resistant weeds of Brazil, according to the Weed Science Society of America 2010.

For the *Bidens subalternans* biotypes resistant to ALS inhibitors, studies by (Gelmini et al., 2002) found that plants from the resistant population showed a high level of cross-resistance to the chemical group of sulfonylurea and imidazolinones, although they were easily controlled by alternative herbicides to soybeans such as fomesafen, bentazon, ammonium glufosinate and glyphosate. Cross-resistance to ALS inhibiting herbicides is the result of a single mutation or combination of two separate mutations in the gene encoding the ALS, where each mutation results in resistance to a group of herbicides belonging to the same chemical group (Wright et al. 1998).

Among the species with multiple resistance in Brazilian territory are *E. heterophylla*, *B. pilosa* and *Echinochloa crusgalli*. Mainly *E. heterophylla* and *B. pilosa* are common species on soybeans and even in the system of cultivation with GM soy, the control of *E. heterophylla* is not possible due to its resistance to glyphosate. Specifically for *E. heterophylla*, a cross

between susceptible and resistant biotypes of this weed results in fully resistant plants, being the genetic inheritance encoded by a dominant nuclear gene with complete dominance (Vargas et al., 2001). This fact, among other abilities of the weed, makes it one of the most problematic in the management of resistant weeds in Brazil.

In Brazil, the emergence of resistance cases involving the herbicide glyphosate is directly related to its intensive use in areas of no-tillage system and other areas of non-selective control of weeds. In the country, besides those already mentioned (*C. bonariensis*, *D. insularis* and *E. heterophylla*), *L. multiflorum* also presents resistance (Vargas et al., 2005) and there are unpublished reports of *B. pilosa* biotypes. All these species are present in GM soy, bringing the need to change the entire control management of weeds in crop. With this, the technology used without caution up to then, loses its usefulness or control potential in areas where these plants are present.

In this sense, it is considered that the management of weed populations resistant to herbicides is a direct consequence of problems related to the prevention of the occurrence of these cases. Therefore, in order to the production system used be sustainable over time, with respect to the control of weed species, it is essential to prevent the outbreak of new cases within the system itself. This fact is proven, since many of the management steps recommended in the areas of resistance are also applicable to the condition of prevention. According to (Retzinger & Mallory-Smith, 1997), the prevention and especially the resistance management should consider: (i) identification and prior knowledge of species and the justifiable economic harm before the establishment of chemical control, (ii) search for alternative methods of weed management (mechanical, cultural, etc.) (iii) use of crop rotation and herbicides with different mechanisms of control, (iv) consider the number of recommended applications of an herbicide or herbicides with the same mechanism of action within the same crop year, (v) using sequential mixtures with herbicides of different mechanisms of action, (vi) evaluation after application of the treatment, looking for areas with signals of weeds.

In Brazil, as in other countries, even after the emergence of resistance, chemical management remains the main tool in the management of the plants. For the species *C. bonariensis*, *D. insularis* and *E. heterophylla*, resistant to glyphosate, the addition of a second or third herbicide to the spray is still regarded as the best alternative. The mixture of herbicides in tank is the first strategy used by the chemical industry. However, many researchers continue their research, seeking to manage sustainably the agricultural environments and propose new management alternatives.

Globally, the body that monitors the evolution and emergence of new accessions of weeds resistant to herbicides, as well as the impact of these biotypes around the world is the Herbicide Resistance Action Committee (HRAC). Its action, in addition to registration and monitoring of resistance worldwide, is the constant updating of new cases. The Committee also has as its mission the promotion of research, while supporting the development of public policies that help farmers and ensure the least impact on natural systems.

2. Mechanisms of weed competition

Many metabolic processes in plants can be influenced by low water availability in the soil, promoting the partial or total closing of the stomata and limiting water loss and, consequently, the CO₂ fixation. When they close, they conserve water and reduce the risk of dehydration. As soon as the availability of water in the soil decreases, the transpiration rate

also decreases, resulting in the closing of the stomata. Thus, stomatal functioning is a physiological impairment, when opened, allowing the assimilation of carbon dioxide. In the agriculture, the competition with weeds reduces growth, the biomass and the grain yield of crops, and the advantage of intercropping among cultures basically depends on the extent to which the species are not competing with each other (Wilson, 1988).

Plants can compete with each other (intraspecific) and with other species of plants (interspecific) for environmental resources (light, water, nutrients, CO₂, etc.). The length of competition time, determines losses in growth, development and hence, in crop production. A considerable reduction in the growth of species, both in intra-and interspecific combinations, is the result of spatial competition between two groups of plants that occupy the same location at a certain time period. Raventós & Silva (1995) affirmed that this reduction, caused by two neighbor plants, could be due to competition for water during the dry season and for light during the wet season, being that the complex nature of competition between plants has been largely ignored, being investigated only in the form of experimental studies and in controlled conditions. However, interspecific competition for environments conducive to plant establishment, over evolutionary time, may be generating adjustments in strategies of species regeneration.

In recent years, research related to the competitive ability of cultivars with weeds have been gaining importance, especially because the adoption of competitive genotypes constitutes a cultural practice that can reduce costs and environmental impacts (Balbinot Jr., 2003). The increase of the competitive capacity of plants is attributed to the early emergence, high seedling vigor, rapid leaf expansion, formation of dense canopy, high height of plant, long development cycle and fast growing of root system (Rees & Bergelson, 1997; Haugland & Tawfuq, 2001; Sanderson & Elwinger, 2002). Plants bearing high speed emergence and early growth have priority in the use of environmental resources and, therefore, generally have an advantage in using these (Gustafson *et al.*, 2004).

According Park *et al.*, (2001), there are two factors that influence the outcome of the competition: i) exhibiting phenotypic plasticity that can be used by a plant in a competitive environment; ii) potential competitive ability (including seed size, seedling size, emergence timing and size of plant).

All these features influence or reflect, in one way or another, the ability of an individual plant to capture resources. The degree of interference in interspecific competition depends on factors related to the weed community (species composition, density and distribution) and on the crop itself (genus, species and cultivar, row spacing and planting density). It also depends on the duration of cohabitation, the time period in which this occurs, being modified by the conditions of soil and climate and by the cultural practices (Kuva *et al.*, 2003).

Competition for resources should not be confused with allelopathy, in accordance with Ferreira (2000). Allelopathy would be any direct or indirect, harmful or beneficial effect that a plant (including microorganisms) has on the production of other chemical compounds released into the environment. What distinguishes allelopathy from competition among plants is that the competition reduces or removes from the environment a growth factor required for both plants (light, water, nutrients, etc.), while allelopathy occurs by adding a factor to the environment. In practice, it is not easy to distinguish whether the adverse effect of a plant on the other is due to competition or to allelopathy (Souza *et al.*, 2003).

Studies based on physiology commonly identify how the capture of a resource by an individual affects the amount of the resource captured by another, without determining the consequences on the performance of the plant. The level of population or community gives

an idea of the phenomenological responses, but fails to identify the intermediate source. The ability to raise funds in the soil and the competitive ability of plants are not necessarily correlated (Casper & Jackson, 1997). Lemaire & Millard (1999) identified five steps for analyzing the effect of plants competition through a mechanistic approach: i) model of the acquisition of source and use by the canopy in the absence of competition; ii) analysis of the canopy response to the reduction of sources, when induced by the presence of neighboring plants; iii) study of the spatial distribution of different physical sources when resulting from the presence of neighboring plants and how plants perceive these changes and develop an integrated response; iv) analysis of signaling plant to plant by means of other means but the quantitative reduction of physical sources; v) sources effects integration with non-source effects in a more understandable model in terms of the stand of the plant.

Weed competition for environmental resources (water, light and nutrients) is frequently described as the direct cause of reduction in crop production, although the limitation of these resources has different effects between species. For soybeans, for example, it appears that competition for light is the main competitive factor for weeds (King & Purcell, 1997). However, other factors such as water and nutrients are involved in defining the competitive ability, which can vary depending on the species, their plasticity and the environmental conditions that occur during their growth.

2.1 Water competition

Ground water is included among the most important resources for which plants compete. The supply of this resource depends on precipitation, evapotranspiration and water movement in the soil profile. In the case of weeds, water and nutrients extraction reduce the availability of these resources for the target culture, which causes stress and ultimately reduces the growth of both and also the yield of the crop (Patterson, 1995).

Competition for water and, consequently, the effects of its stress are undoubtedly factors that also contribute to lowering the productivity of crops (Meckel et al., 1984), as the occurrence of droughts become more and more frequent. In this sense, soy generally shows less tolerance than the weed, as found by Scott & Guedes (1979). Jones Junior & Walker (1993) observed that the water absorption in *Xanthium strumarium* exceeded twice the capacity of soy and *Cassia obtusifolia*. However, soy reduced the water uptake by *C. obtusifolia*, demonstrating that the competitive interactions between species are distinct. According to (Costa et al., 1999), soy tends to maximize the efficiency of radiation use when subjected to water deficit. However, this does not occur in the reproductive phase, mainly because of the higher energy requirement in the formation of the oil and protein content of the grains. Thus, the competition for water is critical to the culture during its reproductive phase, when the demand and translocation of assimilates to the fruits are high.

The effect of water stress on soybean yield, for example, is constantly related to their occurrence period during the crop cycle. It is known that the low water availability in the growing season has an effect on the species productive definition (Costa et al., 1999), being that the highest accumulation of dry matter mass in plants occurs between the beginning of the flowering and the filling of the grains. However, the relationship between water demand and the ability to tolerate drought can be changed. In this condition, it is assumed that the effect of drought should be proportional to the potential of the competitor species on the uptake and efficiency in the water use.

Although scarce, some research has shown that certain weeds may be more competitive under water deficit in relation to the culture, while others may have an equal or lower

ability to compete than the cultivated plants. *Desmodium tortuosum*, for example, shows a greater competitive effect with soybean under low water availability in relation to the absence of stress (Griffin et al., 1989). The same does not happen to *Ambrosia artemisiifolia*, because (Coble et al., 1981) found that in years of droughts, the critical period for control of this species was lower than in years with normal rainfall, representing an increased aggressiveness of *A. artemisiifolia* in normal water supply conditions.

However, few results define precisely the dispute of resources among species, making it difficult to isolate the factors during the competition, especially regarding the interpretation of the effects of water stress, which can interfere in the photosynthesis and growth rates (Flexas et al., 2004), in cell signaling, and according to Bray (2002) on the plants' gene expression.

2.2 Light competition

Solar radiation is a significant component of the competition for some weeds. Above the soil surface, light is perceived by specific photoreceptors, including phytochrome, cryptochromes and phototropin, which induce photomorphogenic responses that influence the investment pattern of the resource that is being captured and the ability of plants to capture additional features (Ballaré & Casal, 2000). The effects of signals perceived by these photoreceptors differ between cultures and weeds (Ballaré, 1999). Furthermore, as noted by Rajcan & Swaton (2001), the mechanisms of competition between plants seem to occur much earlier than what was known until recently. The authors found that environmental signals, such as differential detection of light by plants in the red region (660-670 nm) and far red (730-740 nm) allow the change of the competitive ability between plants. This provides conditions of radiation availability variables in the different extracts of a community, and thus, the ratio red/far red is modified. The understanding of how plants detect, respond and adapt to environmental stimuli is very important for a better farming of the genotypes currently available, however, these studies should be conducted in locations that simulate the situations of crops, i.e., in an environment with natural radiation and plants growing in planting densities. Thus, physiological determinations along with some biochemical analysis can promote the clarification of the mechanisms and period of weed competition in crops.

The determination of the nitrate reductase activity (NR) (EC1.6.6.1.), for example, a key enzyme in the nitrogen metabolism in plants, can collaborate with the studies of competition. It is known that its activity is stimulated by light intensity and duration, and it may respond to different water contents in the soil (Sung, 1993). More recently, the carbohydrate content and other environmental factors have also been identified as agents in the activation of this enzyme (Xu & Zhou, 2004). Thus, we can verify that there is a close relationship between the physiology of plants and their ability to compete with weeds.

Plants generally reach their maximum photosynthetic capacity in conditions of light saturation and decrease their growth rate when exposed to shade. Most of the weeds, however, may change its photosynthetic capacity in response to variations in light intensity (Radosevich et al., 1997). Bazzaz & Carlson (1982) found that annual weeds such as *Ambrosia trifida* L., *Datura stramonium* L. and *Polygonum pensylvanicum* L. have high photosynthetic flexibility, allowing these to grow and reproduce even at low light levels. These adaptation mechanisms allow greater tolerance to low soil fertility, drought stress or shade. The species *Isatis tinctoria* is an example of weed with high plasticity in response to shading, allowing changes in leaf area and its distribution between shoot and root. These modifications enhance the capture of light and allow its survival in the environment (Monaco et al., 2005).

According to the research conducted by Patterson (1982), the species *Cyperus rotundus* also has high capability to modulate according to the light conditions. Its plasticity was evidenced by an increase of 38% in the leaf area when transferred to an environment with 75% of light reduction, allowing greater competition ability.

2.3 Competition for nutrients

Adequate mineral nutrition is essential for the growth and development of plants. When the essential elements are missing or when there is competition between plants for a particular element, the fixation of other elements can also be affected. The competition of competing plants by sources of nitrogen and other minerals in the soil depends on its specific ability to capture these sources (root architecture and absorption properties of root tissue) (Lemaire & Millard, 1999). The high extraction capacity of soil nutrients by plants is an important factor in the delimitation of competitive parameters. In this sense, it was found that increasing plant density (increased competition) caused a decline in the absolute concentration of nitrogen (N), phosphorus (P) and potassium (K) in leaves, stems and vegetables in soybean (Marvel et al., 1992). Ronchi et al. (2003) noted, for example, that *Bidens pilosa* accumulates 5.53, 11.19 and 5.32 times more nitrogen, phosphorus and potassium, respectively, compared to the coffee crop, with maximum accumulation of dry matter mass at the pre-flowering stage. For soybeans, Pitelli et al. (1983) also found increased intake of phosphorus and potassium on dry matter of *Cyperus rotundus* in relation to the crop, which demonstrates the high potential of these species in the uptake of soil nutrients. Soil resources are fetched by the root surface through three processes: i) root interception; ii) flow of water mass and nutrients and iii) diffusion.

Less than 10% of the capitation is due to the root interception (Marschner, 1995). The supplementation of N, P and K, often depends on the mass flow and on the diffusion, processes which are difficult to separate experimentally in the field (Casper & Jackson, 1997). Aerts (1999) affirmed that competition in nutrient-poor environments do not necessarily represent a competitive ability for nutrients and a high growth rate, but may result from features that reduce nutrient losses, i.e. low nutrient concentrations in the tissues and low tissue flow. Thus, the low growth rate of some species in nutrient-poor environments should be considered as a consequence of the higher rate of nutrients retention than the competition for absorbing them.

Soil water can significantly affect the movement and availability of nutrients. Thus, there may be interactions between multiple cations, leading to replacement with a subsequent increase or decrease in its availability (Patterson, 1995). In general, the availability of water and nutrients are positively correlated. On the other hand, Aerts (1999) correlated nutrient availability with light intensity, saying that under high nutrient availability, competition for light occurs primarily. When light is a unidirectional resource, habitats with high nutrient levels are dominated by fast-growing perennials with tall stature and a greater vertical arrangement of the leaf area. Moreover, these species have high flow rate of leaves and roots and a high morphological plasticity during the differentiation of leaves.

3. Methods of weeds control

The degree of interference of weeds on crops depends on the infesting plant community (species, density and population), on the crop (cultivating, spacing and density), environment (soil, climate and management), on the period of coexistence and basically on the control method used.

For soybeans, several studies with weeds show the negative effects of competition on crop productivity, from small reductions to more than 40% drops in income, as reported for the species *Desmodium tortuosum* in soy (Melhorança, 1994).

One of the main alternatives to reduce losses to the crop is to know the critical period of weed interference. The critical periods, currently defined, are grounded in losses of crop productivity resulting from competition by the weeds, highlighting the developmental stage most appropriate for the conduct of its control. However, this definition is currently being discussed, for it considers that only the biotic components of the crop are observed in the determination of critical periods, without knowing the ability of competition and interaction of plant species.

Alternatively, new control programs must be proposed to ensure technological advancement, which shall focus mainly on studies designed to determine the biology and the mechanisms of competition between species (Chao et al., 2005). Some researches have proven the efficiency in the adoption of integrated weed management systems, based on inter-cropping. These systems are supported primarily by descriptive and mechanistic models of analysis, making it possible to optimize inter-cropping.

Considering the control methods fundamentally known, the principle of its application must consider all factors involved in the management system and be based on the use of one or more methods where the cost of implementation is lower than the economic results obtained by it. It must be sustainable, allowing its use to prevail for long periods. Being applicable to the reality of the farmer and to the socioeconomic status, besides being environmentally friendly is also important.

Didactically, control methods are divided into six, and their integration as a form of integrated management of weeds is the safest and least error-prone in the medium and long term. Among the control methods known, we can mention: preventive, cultural, mechanical, physical, chemical and biological.

3.1 Preventive

The preventive control aims, as its name already says, to prevent the introduction of weeds which are difficult to control and prevent their spread and or reproduction, keeping the other species in controllable conditions that will not cause economic damage to the crop. The main action of preventive control is the acquisition of certified commercial seed with high purity without the presence of other species. Once this measure is observed, one should be careful in the handling of agricultural machinery and implements so that they do not disseminate or introduce weeds species to the area under cultivation.

For soybeans, production and marketing of seeds shall conform to standards established by the Brazilian law in 2009. Among other prohibited species, the main is *Vigna unguiculata*, which can not be present in fields of seed production. This measure, as well as other levels of tolerance for other weed species is fundamental to the success of production and helps as a preventive management measure.

The practice of cleaning in areas with terraces and level curves, fences lines, road edges and irrigation and drainage canals also help as a preventive measure against the installation of weeds. Another simple but not very used practice is the area management area at the time between crops or second-crop. The control of plants, regardless of which method is used, is also part of the preventive management of species, for it seeks to reduce the spread and/or reproduction of weeds such as *E. heterophylla*, *Bidens pilosa*, *Tridax procumbens*, etc. which increase significantly the seed bank. The management between crops can be conducted by

the integrated use of cover crops associated with sequential applications of non-selective desiccants.

3.2 Cultural

The cultural control is among the most important means of weed management and can be easily used by all producers of soy and other cultures. Some management tools make up the cultural control, such as crop rotation, use of cultivars adapted to climate and regional conditions, the adequacy of the spacing of the crop depending on the technology available and on the weed species, use of plants as green fertilizers, etc.

For soybeans, especially in the south, one of the major problems is the presence of *Cardiospermum halicacabum*. This species has an annual cycle and, besides reducing productivity, it later hampers the harvest. For it is so difficult to control, an alternative to its reduction in soybean area is the use of annual rotation with corn, allowing also the rotational chemical control. In the rotation system, especially linked to direct sowing, the diversity of organisms in the soil layer is also larger, allowing many microorganisms to conduce to degradation of dormant seeds through its deterioration and loss of viability.

The spacing and sowing density are further tools in cultural management and allow less weed interference in soybeans, basically to plants with low tolerance to shade. Usually, the density experiments for weed control are conducted in gramineae: maize, rice and also wheat. However, even in soybean, studies conducted in Brazil show that reducing the spacing between rows of crops (e.g. 60 cm to 30 cm) interferes with the period of weed control (Melo et al., 2001).

Another means of cultural control is the use of green coverage in areas with high infestation of plants. Often, the species used in Brazil are legumes such as *Canavalia ensiformes*, *Cajanus cajan*, *Mucuna aterrinum*, *Mucuna deeringiana* and *Crotalaria juncea*. These species have a great potential for nutrient cycling in soil and fixation of atmospheric nitrogen. For regions with high incidence of nematodes (*Meloidogyne incognita*, *M. Javanica*, *Pratylenchus brachyurus* and *Rotylenchulus reniformis*, the green cover with *Crotalaria juncea* or sorghum and millet are also recommended. In cooler regions, south and southwestern Brazil, other species are grown for formation of green pot plants, among them *Lupinus albus*, *Lolium multiflorum*, *Vicia villosa*, *Avena strigosa* and others.

In general, any cultural practices which have the objective to accelerate the growth of the culture and that reduce the growth and development of weeds can be considered as a practice of culture management.

3.3 Mechanical

Currently, the mechanical control is used on a small scale, especially for soybeans, a commodity which is mostly represented by medium and large producers. Among the mechanical methods used, it appears that the hand-weeding is the most widespread, although they also use the mechanical weeding or the mowing through mowing tractors, as well as cultivators. The latter are common in other cultures that have a wider sowing spacing.

For mechanical control, the selection of equipment appropriate to the conditions of the farming system and to the crop implementation system is very important. Under organic farming, for example, the use of mechanical control in soybeans is necessary and adapting the models of machines used, over 70% of the weeds present can be eliminated.

Often, as in manual weeding, mechanical weeding demand more than one management. Special care related to the time of year is also fundamental. The beginning or first weeding should occur between 15 and 20 days after the crop emergence, not exceeding this period, especially when the area is infested with graminiae, which grow extremely fast. For the second weeding, the limit is established between the 25th and 30th days, although these periods are variable depending on the cultivars, weeds and soil and climatic conditions. In case of use of mechanical weeding with rotary drag device, the initial period shall not extend to plants with more than two pairs of leaves, for besides being harmful to the crop, the efficiency of the control will be lower.

The main limitation of this type of management is the time needed to complete the task and the short period of time for its conduction, since the weeds show a rapid natural growth. Thus, all equipment used must be calibrated and adjusted to the cropping system used. Soil moisture at the time of completion of the weeding is also important, especially for the rotary drag.

3.4 Physical

Although widespread in other countries, the physical control in Brazil is rarely used. This method is based on techniques that seek to control weeds by physical actions of water, heat, radiation, among others. As an example, we can mention the control of *Cynodon dactylon* and *Cyperus rotundus* through flooding, often used in rice cultivation.

In Brazil, a prime example of physical control in soybeans is the direct sowing, which allows the formation of an extensive layer of straw on the ground. The straw acts as a physical barrier against the germination of many weeds that need light to germinate or even hinders the emergence of weeds with very small seeds. Besides this effect, the no tillage and the accumulation of straw present other means of weed control. Even the allelopathic effects of cover plants through the release of substances from straw decomposition are a form of control, although its principle is classified within the chemical control.

Other examples known are the mulching and solarization techniques, although they are not applied in the cultivation of soybeans, they show an excellent control on vegetable and fruits crops. Their high cost and the need of control before the start of the cultivation makes its use in major crops impossible.

3.5 Chemicals

Chemical control is currently the most widely used control for soybean crops, due to its ease of control and to the large areas planted in Brazil. Such management includes pre and post-emergence herbicides, desiccants with a wide spectrum of action and non-selective with low residual power.

Choosing the chemical management for weed has been changed by the adoption of GMO soybean cultivars. Therefore, the management can vary depending on several factors, among them, the main thing is the cost of the management system. In this case, one should also take into account the cost of the GMO seeds and of the weed control.

Soybean cultivars tolerant to glyphosate (GMOs) often provide more flexibility to control a broad spectrum of weeds in soybean (Reddy, 2001). Thus, despite the higher cost of transgenic cultivars seeds, the low cost and the ease in controlling weeds has been favorable to this market.

Another important factor in this system is the time of application of glyphosate, more than the dose of the product used. Therefore, despite the need to amend the application rates

depending on the size of the weeds, the stage of implementation becomes essential when common weeds like *Chenopodium album*, *Sesbania exaltata*, *Ipomea spp.*, *Abutilon theophrasti*, *Spermacoce latifolia* or even *Commelina benghalensis* are present.

3.5.1 GM soy

Currently, the lack of residual effect in the programs of GM soy in post-emergence has required multiple applications or the use of herbicides with stronger effect in new emergencies. Thus, since the glyphosate does not provide residual effect, weeds can emerge and grow during the growing season of the crop.

In this control program, it is important that the sequential application of glyphosate is mainly done between the growth stages 13 and 14. Applications made between the 3rd and 5th weeks after planting offer an effective control of many weeds. The second (sequential) application of glyphosate spaced 10-14 days after the first application is necessary to control weeds with later emergency or difficult to control.

In a culture system with high infestation of *Commelina benghalensis*, it is advisable to make a spray of glyphosate approximately 30 days before sowing. After the sowing, an application of glyphosate at 2.0 L ha⁻¹ is performed 15 days after the emergence and in sequence, 2.0 L ha⁻¹ 15 days after the first application.

For the cases of a single application of glyphosate, the application of a pre-emergence in order to delay the future application of glyphosate is recommended. The pre-emergence herbicides reduce the early weed interference and allow a greater flexibility in the use post-emergence. This can be important, mainly in the rainy season in which the application is not possible, allowing greater ease of management. Although the use of pre-emergence herbicides is recommended, it increases the cost of the program, being viable only in case of need for additional control (Reddy, 2001).

In a general way, producers, mainly from southern Brazil, perform the desiccation in the prior crop to serve as mulch. After approximately 15 days, the sowing on the straw is started. The application of glyphosate in post-emergence is performed when the soybeans have three trifoliolate leaves, according to the level of infestation of weeds. In this case, the principal for the single application of glyphosate in soybean GMO is to perform the spraying when most weeds have already emerged, without allowing, however, the reduction of the crop yield.

3.5.2 Conventional soybeans

In conventional soybeans not resistant to glyphosate, the chemical control of weeds should mainly consider the selectivity of the crop to the herbicide, followed by observation of the application technology, as well as other important details such as the mixture of compounds, the environmental conditions, and the use of adjuvants, among others.

Usually, the system of plowing and harrowing for soil preparation is used in the sowing of conventional soybeans. In the case of direct sowing, the chemical control program is very similar, considering that, in this system, glyphosate is used as a desiccant in the pre-sowing rather than the use of mechanic control. For no tillage in non-GM soy, the different management of weeds in the fallow period is also important, and we can use products such as paraquat, glyphosate, 2-4 D, chlorimuron or carfentrazone.

After sowing, followed by the application of a pre-emergence, monitoring the area is necessary. In many areas where the weed infestation is small, the use of a post-emergence is

not necessary, or farmers use to spray only specific post-emergence. In area with high infestation, selective post-emergence applications are performed, both to monocotyledons and dicotyledons.

Although still under-explored in studies, the allelopathic effect of vegetable covering species on the weed control is also considered as chemical control, because its action occurs by releasing substances from the decomposition process of straw on the soil cover. The effects can occur both from crops to weeds as from weeds to crops. Among the species with proven effect, we can mention *Brachiaria decumbens*, *Pennisetum typhoides*, *Cajanus cajan*, *Brassica napus*, among others. Innumerable studies are aimed at evaluating the effect of allelopathic substances in the reduction of seed banks and weed control. Especially in systems of crop rotation and where green manure is used, many species assist in weed management, along with other control methods.

3.6 Biological

The biological control of weeds is still very limited, because a major problem is the selectivity of the species in relation to the culture of interest, as well as the system of multiplication of control organisms. These may be fungi, bacteria, viruses or even birds, insects, fish, etc.

In the country, some attempts were made to control extracts and chemical compounds obtained from biomass produced by *Pestalotiopsis guepinii*. Its effect was more significant in the germination of some weeds than on the seedling development. From the species tested, *Mimosa pudica* showed greater sensitivity to the inhibitory effects of the extracts (Santos et al. 2008).

Another example of use, but not in soy, is the application of a isolate of *Fusarium graminearum* as a biological control agent of *Egeria densa* and *E. najas*, submerged aquatic plants that cause problems in hydroelectric dams (Borges Neto et al., 2005), as well as the use of fish (*Piaractus mesopotamicus*) in the control of these species (Miyazaki & Pitelli, 2003).

3.7 Integrated control (Integrated Management of Weeds)

The principle of integrated weed management (IWM) is the management of all factors that affect the crop yield related to the weed population, in order to allow the crop to express its potential productivity. The IWM is to provide the maximization of resources with maximum efficiency. Moreover, the integrated management searches to equalize the environmental, economic and social issues in order to make the production system sustainable in long term. In this regard, some initiatives in combination of control methods are being used. But we are still far from the IWM. In Brazil, as in other parts of the world, the integrated management is not practiced, but we practice an integration of methods which provide a satisfactory control of weeds at lowest cost.

Some examples in soybean illustrate the shortage of IWM, among them: over-sowing systems of *Brachiaria brizantha*, *B. ruziziensis* and *B. decumbens*, helping in the management of weeds of emergency sequential to the culture (Pacheco et al., 2009), as a tool to reduce the seed bank of other weeds in the crop.

The combination of chemical control with the use of sorghum straw coverage in soybean is also a further alternative in the control of various weeds, such as *Leonotis nepetifolia*, *Alternanthera tenella*, *Amaranthus hybridus*, *A. retroflexus*, *A. spinosus*, *Ipomoea grandifolia*,

Commelina benghalensis and *Nicandra physaloides*, besides helping reducing the use of post-emergence herbicide (Correia et al., 2005).

Variations in spacing of the culture, along with applications of post-emergence herbicides for controlling *Brachiaria plantaginea* (Pires et al., 2001) is another study for integrating control methods, although with no bases of IWM.

From a technical standpoint, the IWM must consider the biology and the ecological relationships of species. Seeking to understand the dynamics of nutrient cycling between compositions of weeds and crop. Relating the pressure of pathogens and pests to the presence or absence of weeds at the site and understand their symbiosis. All these aspects show how important and multidisciplinary the adoption of integrated management systems is, as well as our need to improve our research.

4. References

- Adegas, F. S. (1998). Manejo integrado de plantas daninhas em plantio direto no Paraná. In: Seminário nacional sobre manejo e controle de plantas daninhas em plantio direto, pp. 17-26. Passo Fundo-RS. Palestras... Passo Fundo, Aldeia Norte, RS.
- Aerts, R. (1999). Interspecific competition in natural plant communities: mechanisms, trade-offs and plant-soil feedbacks. *Journal of Experimental Botany*, Vol.50, No. 330, (29-37), ISSN 1460-2431.
- Altieri, M.A (1991). Increasing biodiversity to improve insect pest management in agroecosystems. In: The biodiversity of microorganism and invertebrates: its roles in sustainable agriculture. Ecological Foundations of Sustainable Agriculture (WEFSA, 1) 1991, Wallingford, UK, Proceedings...Wallingford: Cab International, 1991, p.165-182.
- Aspiazú, I.; Sediyaama, T.; Ribeiro Jr., J. I.; Silva, A. A.; Concenco, G.; Galon, L.; Ferreira, E. A.; Silva, A. F.; Borges, E. T. & Araujo, W. F. (2010). Characteristics associated to photosynthesis and water use of weed species. *Planta Daninha*, Vol. 28, No. 1, (87-92), ISSN 1806-9681
- Ballaré, C.L. (1999). Keeping up with the neighbours. Phytochrome sensing and other signaling mechanisms. *Trends in Plant Science*, Vol.4, No.2, p.97-102, ISSN: 1360-1385.
- Ballaré, C.L. & CASAL, J.J. (2000). Light signals perceived by crop and weed plants. *Field Crops Research*, Vol.67, No.2, (149-160), ISSN: 0378-4290.
- Baumann, D. T.; Bastiaans, L. & Kropff, M. J. (2001). Competition and crop performance in a leek-celery intercropping system. *Crop Science*, Vol. 41, (764-774), ISSN 0011-183X.
- Balbinot Jr., A.A.; Fleck, N.G.; Barbosa Neto, J.F. & Rizzardi, M.A. (2003). Characteristics of rice plants and their competitive ability with weeds. *Planta Daninha*, Vol.21, No.2, (165-174), ISSN 1806-9681.
- Borges Neto, C. R.; Gorgati, C. Q. & Pitelli, R. A. (2005). Influence of the photoperiod and temperature on the intensity of disease caused by *Fusarium graminearum* in *Egeria densa* and *E. najas*. *Planta Daninha*, Vol. 23, No.3, (449-456), ISSN 1806-9681.

- Buzatti, W. J. de S. (1999). Controle de plantas daninhas no sistema plantio direto na palha. In: Plantio direto: atualização tecnológica. Pauletti, V.; Seganfredo, R., (Ed.), (97-111). Fundação Cargill/Fundação ABC, ISBN , São Paulo
- Brazzaz, F.A. & Carlson, R.W. (1982). Photosynthetic acclimation of early and late successional plants. *Oecologia*, Vol.54, (313-316), ISSN: 1432-1939.
- Bray, E. (2002). Abscisic acid regulation of gene expression during water deficit stress in the era of the Arabidopsis genome. *Plant Cell and Environmental*, No.5, 153-161, ISSN: 0140-7791.
- Carmona, R. & Villas Bôas, H. D. C. (2001). Dinâmica de sementes de *Bidens pilosa* no solo. *Pesquisa Agropecuária Brasileira*, Vol. 36, No.3, (457-463), ISSN 0100204X.
- Carmona, R. (1992). Problemática e manejo de bancos de sementes de invasoras em solos agrícolas. *Planta Daninha*, Vol. 10, (5-16), ISSN 1806-9681.
- Casper, B.B. & Jackson, B.R. Plant competition underground. *Annual reviews of Ecology and Systematic*. Vol. 28, (545-570), ISSN: 0066-4162.
- Chao, W.S.; Horvath, D.P.; Anderson, J.V. & Foley, M.E. (2005). Potential model weeds to study genomics, ecology, and physiology in the 21st century. *Weed Science*, Vol.53, No.6, (929-937), ISSN 1550-2759
- Christoffoleti, P. J. & López-Ovejero, R. (2003). Principais aspectos da resistência de plantas daninhas ao herbicida glyphosate. *Planta Daninha*, Vol.21, No.3, (507-515), ISSN 1806-9681
- Christoffoleti, P.J. & López-Ovejero, R. (2003). Main aspects on weed herbicide resistance to glyphosate. *Planta Daninha*, Vol.21, No.3, (507-515), ISSN 1806-9681.
- Coble, H.D., Williams, F.M., & Ritter, R.L. (1981). Common ragweed (*Ambrosia artemisiifolia*) interference in soybean (*Glycine max*). *Weed Science*, n.29, (339-342), ISSN: 1550-2759.
- Correia, N.M.; Souza, I.F. & Klink, U.P. (2005). Sorghum mulch combined with imazamox for weed control in soybeans planted in succession. *Planta Daninha*, Vol. 23, No.3, (483-489), ISSN 1806-9681.
- Costa, L.C.; Confalone, A. & Pereira, C.R. (1999). Effect of water stress on the efficiency of capture of water and radiation by soybean. *Tropical Science*, Vol.39, (91-97), ISSN 1556-9179.
- Dick, D. P.; Gomes, J. & Rosinha, P.B. (1998). Caracterização de substâncias húmicas extraídas de solos e de lodo orgânico. *Revista Brasileira de Ciência do Solo*, Vol. 22, (603-611), ISSN 1806-9657.
- Faostat – Food and Agriculture Organization of the United Nations (Statistical Databases) 2008. <http://faostat.fao.org/faostat>
- Ferreira, A.G. & Aquila, E.A. Alelopatia: uma área emergente da ecofisiologia. *Revista Brasileira de Fisiologia Vegetal*, Vol. 12, (175-204), ISSN: 01033131.
- Flexas, J.; Bota, J.; Loreto, F.; Cornic, G. & Sharkey, T.D. (2004). Diffusive and metabolic limitations to photosynthesis under drought and salinity in C₃ plants. *Plant Biology*, No.6, (269-279), ISSN: 1435-8603.
- Freitas, R.S.; Berger, P.G.; Ferreira, L.R.; Silva, A.C.; Cecon, P.R.; Silva, M.P. (2006). Weed management of cotton under no-tillage. *Planta Daninha*, Vol.24, No. 2, (339-346), ISSN 1806-9681.

- Gelmini, G. A.; Victória Filho, R.; Novo, M. C. S. S. & Adoryan, M. L. (2002). Resistance of *Bidens subalternans* to the acetolactate synthase inhibitor herbicides used in soybean crop. *Planta Daninha*, Vol. 20, No. 2, (319-325), ISSN 1806-9681.
- Gustafson, D.J.; Gibson, D.J.; Nickrent, D.L. (2004). Competitive relationships of *Andropogon gerardii* (Big Bluestem) from remnant and restored native populations and select cultivated varieties. *Functional Ecology*, Vol. 18, (451-457), ISSN 0269-8463.
- Griffin, B.S.; Shilling, D.G.; Bennet, J.M. & Currey, W.L. (1989). The influence of water stress on the physiology and competition of soybean (*Glycine max*) and Florida beggarweed (*Desmodium tortuosum*). *Weed Science*, Vol.37, (544-551), ISSN: 0043-1745.
- Haugland E. & TAWFIQ, M. (2001). Root and shoot competition between established grass species and newly sown seedlings during spring growth. *Grass and Forage Science*, Vol.56, (193-199), ISSN 0142-5242.
- Jones Jr, R. E. & Walker, R. H. (1993). Effect of interspecific interference, light intensity, and soil moisture on soybean (*Glycine max*), and sicklepod (*Cassia obtusifolia*) water uptake. *Weed Science*, Vol. 41, (534-540), ISSN: 0043-1745.
- King, C.A., & Purcell, L.C. (1997). Interference between hemp sesbania (*Sesbania exaltata*) and soybean (*Glycine max*) in response to irrigation and nitrogen. *Weed Science*, Vol.45, (91-97), ISSN: 0043-1745.
- Kissmann, K. G. & Groth, D. (1992). Plantas infestantes e nocivas. BASF Brasileira, São Paulo, SP.
- Kuva, M.A.; Gravena, R.; Pitelli, R.A.; Christoffoleti, P.J.; Alves, P.L.C. (2003). Interference periods of weeds in the sugarcane crop: III - *Brachiaria decumbens* and *Panicum maximum*, *Planta Daninha*, Vol.21, No.1, (37-44), ISSN 1806-9681.
- Lamego, F. P. & Vidal, R. A. (2008). Resistance to glyphosate in *Conyza bonariensis* and *Conyza canadensis* biotypes in Rio Grande do Sul, Brazil. *Planta Daninha*, Vol.26, No.2, (467-471), ISSN 1806-9681.
- Lee, L. J. & Ngim, J. (2000). A first report of glyphosate-resistant goosegrass (*Eleusine indica* (L.) Gaertn.) in Malaysia. *Pest Management Science*, Vol. 56, (336-339), ISSN 1526-4998.
- Lemaire, G. & Millard, P. (1999). Ecophysiological approach to modeling resource fluxes in competing plants. *Journal of Experimental Botany*, Vol.50, (15-28), ISSN 1460-2431.
- Machado, A. F. L.; Ferreira, L. R.; Ferreira, F. A.; Fialho, C. M. T.; Tuffi Santos, L. D. & Machado, M. S. (2006). Growth analysis of *Digitaria insularis*. *Planta Daninha*, Vol.24, No.4, (641-647), ISSN 1806-9681.
- Marschner, H. (1995). Mineral nutrition of higher plants, 2nd edn. London: Academic Press
- Marvel, J.N.; Beyrouty, C.A. & Gbur, E.E. (1992). Response of soybean growth to root and canopy competition. *Crop Science*, Vol.32, (797-801), ISSN 1435-0653.
- Meckel, L.; Egli, D.B.; Phillips, R.E.; Radcliffe, D. & Legget, J.E. (1984). Effect of moisture stress on seed growth in soybeans. *Agronomy Journal*, Vol.76, (647-650), ISSN 1435-0645.

- Melhorança, A. L. (1994). Interferência entre plantas de *Desmodium tortuosum* (Sw) DC. e de *Glycine max* (L.) Merrill. Botucatu. PhD Thesis..., Faculdade de Ciências Agrárias e Veterinárias, Universidade Estadual Paulista, São Paulo, SP.
- Melo, H. B.; Ferreira, L. R.; Silva, A. A.; Miranda, G. V.; Rocha, V. S. & Silva, C. M. M. (2001). Weed interference in soybean crop cultivated in two row spacings. *Planta Daninha*, Vol. 19, No.2, (187-191), ISSN 1806-9681.
- Meschede, D.K.; Oliveria Junior, R.S.; Constantim, J. & Scapim, C.A. (2004). Period before weed interference in soybean: a case-study under low crop density and twofold checks. *Planta Daninha*, Vol.22, (239-246), ISSN 1806-9681.
- Miyazaki, D.M.Y. & Pitelli, R. A. (2003). Evaluation of the biocontrol potential of pacu (*Piaractus mesopotamicus*) for *Egeria densa*, *E. najas* and *Ceratophyllum demersum*. *Planta Daninha*, Vol.21, (53-59), ISSN 1806-9681.
- Monaco, T.A.; Johnson, D.A. & Creech, J.E. (2005). Morphological and physiological responses of the invasive weeds *Isatis tinctoria* to contrasting light, soil-nitrogen and water. *Weed Reseach*, Vol.45, (460-466), ISSN 0043-1737.
- Nepomuceno, M.; Alves, P.L.C.A.; Dias, T.C.S.; Pavani, M.C.M.D. (2007). Periods of weed interference in soybean under tillage and no-tillage systems. *Planta Daninha*, Vol.25, No.1, (43-50), ISSN 1806-9681.
- Oerke, E.C & Dehne, H.W. (2004). Safeguarding production losses in major crops and the role of crop protection. *Crop Protection*, No.3, (275-285), ISSN 0261-2194.
- Pacheco, L. P.; Pires, F. R.; Monteiro, F. P.; Procópio, S. O. ; Assis, R. L.; Cargnelutti Filho, A.; Carmo, M. L. & Petter, F.A. (2009). Soybean crop oversowing used as a technique to suppress weed emergence. *Planta Daninha*, Vol. 27, No.3, (455-463), ISSN 1806-9681.
- Paes, J. M. V. & Rezende, A. M. de. (2001). Manejo de plantas daninhas no sistema plantio direto na palha. *Informe Agropecuário*, Vol.22, No.208, (37-42), ISSN 0100-3364.
- Park, S.A.; Benjamin, R.L.; Watkinson, A.R. (2001). The theory and application of plant competition models: an agronomic perspective. *Ecology*, Vol.82, No.9, (2525 -2535), ISSN 0012-9658.
- Patterson, D.T. (1995). Effects of environmental stress on weed/crop interactions. *Weed Science*, Vol.43, No.3, (483-490), ISSN 1550-2759.
- Pereira, E. S.; Velini, E. D.; Carvalho, L. R. & Rodella, R. C. S. M. (2000). Quantitative and qualitative weed evaluation of soybean crop in no-tillage and conventional tillage systems. *Planta Daninha*, Vol.18, No.2, (207-216), ISSN 1806-9681.
- Pereira, F. A. R. & Velini, E. D. (2003). Tillage systems in the Cerrado and dynamics of weed populations. *Planta Daninha*, Vol.21, No.3, (355-363), ISSN 1806-9681.
- Perez, A. & Kogan, M. (2003). Glyphosate-resistant *Lolium multiflorum* in Chilean orchards. *Weed Research*, Vol. 43, (12-19), ISSN 0043-1737.
- Petter, F.A.; Procópio, S.O.; Cargnelutti Filho, A.; Barroso, A.L.L.; Pacheco, L.P.; Bueno, A.F. (2007). Associations among glyphosate and insecticides in Roundup Ready® soybean. *Planta Daninha*, Vol.25, No. 2, (389-398), ISSN 1806-9681.
- Pires, J.L.F.; Neves, R.; Agostinetto, D.; Costa, J. A. & Fleck, N. G. (2001). Reduced post-emergence herbicide rate associated with soybean reduced row spacing to

- control *Brachiaria plantaginea*. *Planta Daninha*, Vol.19, No.3, (337-343), ISSN 1806-9681.
- Pitelli, R. A., J. C. Durigan, and N. J. Benedetti. (1983). Interspecific and intraspecific competition of *Glycine max* (L.) Merrill and *Cyperus rotundus* L. in greenhouse conditions. *Planta Daninha*, Vol.6, (129-137), ISSN 1806-9681.
- Procópio, S. O.; Santos, J.B.; Silva, A. A.; Martinez, C. A. & Werlang, R. (2004). Physiological characteristics of soybean and common bean crops and three weed species. *Planta Daninha*, Vol.22, No.2, (211-216), ISSN 1806-9681.
- Radosevich, S., Holt, J., & Ghersa, C. (1997). Associations of weeds and crops. 2nd Ed. In: *Weed Ecology – implications for management*. New York: John Willey & Sons, 1997, p.163-214.
- Rajcan, I.; Swanton, C. J. (2001). Understanding maize-weed competition: resource competition, light quality and the whole plant. *Field Crops Research*, Vol.71, No.2, (139-150), ISSN 0378-4290.
- Reddy, K.N. (2001). Glyphosate-resistant soybean as a weed management tool: opportunities and challenges. *Weed Biology and Management*, Vol. 1, (193-202), ISSN 1444-6162.
- Rees, M. & Bergelson, J. (1997). Asymmetric light and founder control in plant communities. *Journal Theory Biology*, Vol.184, (353-358), ISSN: 0022-5193.
- Retzinger, E. J. & Mallory-Smith, C. (1997). Classification of herbicides by site of action for weed resistance management strategies. *Weed Technology*, Vol. 11, (384-393), ISSN 1550-2740.
- Roman, E. S. (2002). Plantas daninhas: manejo integrado na cultura do milho e de feijão. *Revista Plantio Direto*, Vol. 72, (218-230).
- Ronchi, C.P.; Terra, A.A.; Silva, A.A.; Ferreira, L.R. (2003). Nutrient contents of coffee plants under weed interference, *Planta Daninha*, Vol.21, No.2, (217-227), ISSN 1806-9681.
- Ruedell, J. (1995). *Plantio direto na região de Cruz alta*. Pp. 134, 1995, Fundacep, Fecotrigo, Cruz Alta, RS.
- Sanderson, M.A. & Elwinger, G.F. (2002). Plant density and environment effects Orchardgrass-White clover mixtures. *Crop science*, Vol. 42, (2055-2063), ISSN 1435-0653.
- Santos, L.S.; Oliveira, M.N.; Guilhon, G.M.S.P.; Santos, A.S.; Ferreira, I.C.S.; Lopes Jr., M.L.; Arruda, M.S.P.; Silva, M.N.; Souza Filho, A.P.S.; Rodrigues-Filho, E. & Oliveira, M. C.F. (2008). Herbicide potential of the biomass and chemical compounds produced by the fungus *Pestalotiopsis guepinii*. *Planta Daninha*, Vol.26, No.3, (539-548), ISSN 1806-9681.
- Salgado, T.P.; Salles, M.S.; Martins, J.V.F.; Alves, P.L.C.A. (2007). Weed interference in carioca beans (*Phaseolus vulgaris*). *Planta Daninha*, Vol.25, No. 3, (443-448), ISSN 1806-9681.
- Scott, H.D. & Guedes, R.D. (1979). Plant water of soybean (*Glycine max*) and common cocklebur (*Xanthium pensylvanicum*): a comparison under field conditions. *Weed Science*, Vol.27, (285-289), ISSN 1550-2759

- Sindag (2006). Sindicato Nacional da Industria de Produtos para a Defesa Agrícola. http://www.sindag.com.br/dados_mercado.php
- Souza, L.S.; Velini, E.D.; Maiomoni-Rodella, R.C.S. Allelopathic effect of weeds and concentrations of *Brachiaria decumbens* on the initial development of eucalyptus (*Eucalyptus grandis*). *Planta Daninha*, Vol.21, No.3, (343-354), ISSN 1806-9681.
- Souza, M. C.; Pitelli, R. A.; Simi, L.D. & Oliveira, M. C. J. (2009). Seed emergence of *Bidens pilosa* at different sowing depths. *Planta Daninha*, Vol.27, No.1, (29-34), ISSN 1806-9681.
- Sung, F.J.M. (1993). Waterlogging effect on nodule nitrogenase and leaf nitrate reductase activities in soybeans. *Field Crops Research*, Vol.35, (183-189), ISSN: 0378-4290.
- VanGessel, M.J. (2001). Glyphosate-resistant horseweed from Delaware. *Weed Science*, Vol.49, No.6, (703-705), ISSN 1550-275.
- Vargas, L.; Borém, A. & Silva, A. A. (2001). Inheritance of ALS inhibitor resistance in *Euphorbia heterophylla* weed biotypes. *Planta Daninha*, Vol.19, No.3, (331-336), ISSN 1806-9681.
- Vargas, L.; Roman, E. S.; Rizzardi, M. A. & Silva, V.C. (2005). Change in the biological characteristics of ryegrass (*Lolium multiflorum*) biotypes caused by resistance to the herbicide glyphosate. *Planta Daninha*, Vol. 23, No.1, (153-160), ISSN 1806-9681.
- Vidal, R. A. & Merotto Jr., A. (2001). *Herbicidologia*. Porto Alegre: Evangraf, ISBN, Porto Alegre, RS.
- Vidal, R. A. & Winkler, L. M. (2004). *Euphorbia heterophylla* L. resistant to herbicide inhibitors of acetolactate synthase: ii – geographic distribution and genetic characterization of biotypes from rio grande do sul plains. *Revista Brasileira de Agrociência*, Vol.10, No.4, (461-465), ISSN 0104-8996.
- Vidal, R.A.; Fleck, N.G.; Merotto Jr., A. (2005). Weedy period prior to economic loss (WEEPPPEL): a new approach to weedy and weed-free periods. *Planta Daninha*, Vol.23, No.3, (387-396), ISSN 1806-9681.
- Vivian, R.; Silva, A. A.; Gimenes Jr. M.; Fagan, E.B.; Ruiz, S.T. & Labonia, V. (2008). Weed seed dormancy as a survival mechanism – brief review. *Planta Daninha*, Vol.26, No.3, (695-706), ISSN 1806-9681.
- Voll, E.; Gazziero, D. L. P.; Brighenti, A. M.; Adegas, F. S.; Gaudêncio, C. A. & Voll, C.E. (2005). A dinâmica das plantas daninhas e práticas de manejo, Documento 260, pp. 85, ISBN Londrina: Embrapa Soja, Londrina, PR.
- Xu, Z., & Zhou, G. (2004). Research advance in nitrogen metabolism of plant and its environmental regulation. *Chinese Journal of Applied Ecology*, Vol.15, No.3, (511-516), ISSN: 1001-9332.
- Wright, T. R. et al. (1998). Biochemical mechanism and molecular basis for ALS-inhibiting herbicide resistance in sugarbeet (*Beta vulgaris*) somatic cell selections. *Weed Science*, Vol.46, No.1, (13-25), ISSN 1550-275.
- Wu, H. & Walker, S. (2004). Fleabane biology and control. Proceedings of fleabane workshop, Eds S. Walker, M. Widderick and H. Wu, pp. 29-30. (Queensland DPI, Toowoomba).

- Yamashita, O. M. & Guimarães, S. C. (2010). Germination of *Conyza canadensis* and *Conyza bonariensis* seeds in function of water availability in the substrate. *Planta Daninha*, Vol.28, No.2, (309-317), ISSN 1806-9681.
- Yenish, J. P.; Doll, J. D. & Buhler, D. D. (1992). Effects of tillage on vertical distribution and viability of weed seed in soil. *Weed Science*, Vol. 40, (429-433), ISSN 1550-275.

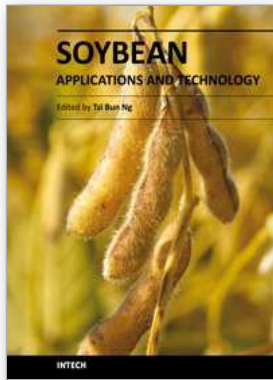

Soybean - Applications and Technology

Edited by Prof. Tzi-Bun Ng

ISBN 978-953-307-207-4

Hard cover, 402 pages

Publisher InTech

Published online 26, April, 2011

Published in print edition April, 2011

Soybean is an agricultural crop of tremendous economic importance. Soybean and food items derived from it form dietary components of numerous people, especially those living in the Orient. The health benefits of soybean have attracted the attention of nutritionists as well as common people.

How to reference

In order to correctly reference this scholarly work, feel free to copy and paste the following:

Andre Rodrigues dos Reis and Rafael Vivian (2011). Weed Competition in the Soybean Crop Management in Brazil, *Soybean - Applications and Technology*, Prof. Tzi-Bun Ng (Ed.), ISBN: 978-953-307-207-4, InTech, Available from: <http://www.intechopen.com/books/soybean-applications-and-technology/weed-competition-in-the-soybean-crop-management-in-brazil>

INTECH

open science | open minds

InTech Europe

University Campus STeP Ri
Slavka Krautzeka 83/A
51000 Rijeka, Croatia
Phone: +385 (51) 770 447
Fax: +385 (51) 686 166
www.intechopen.com

InTech China

Unit 405, Office Block, Hotel Equatorial Shanghai
No.65, Yan An Road (West), Shanghai, 200040, China
中国上海市延安西路65号上海国际贵都大饭店办公楼405单元
Phone: +86-21-62489820
Fax: +86-21-62489821

© 2011 The Author(s). Licensee IntechOpen. This chapter is distributed under the terms of the [Creative Commons Attribution-NonCommercial-ShareAlike-3.0 License](#), which permits use, distribution and reproduction for non-commercial purposes, provided the original is properly cited and derivative works building on this content are distributed under the same license.

Improving the Cold Flow Properties of Biodiesel by Fractionation

Robert O. Dunn

*Bio-Oils Research, USDA-ARS-NCAUR, Peoria, IL
U. S. A.*

1. Introduction

Biodiesel is generally defined as the mono-alkyl esters of fatty acids derived from transesterification of agricultural lipids with a short-chain alcohol. Biodiesel must conform to fuel property specifications such as those outlined in the American Society of Testing and Materials (ASTM) standard D 6751 or the European Committee for Standardization EN 14214 (ASTM, 2008b; CEN, 2003). Although the most common form of biodiesel in the U. S. is made from soybean oil, many other types of lipid feedstocks have been developed. Biodiesel is compatible with compression-ignition (diesel) engines. It may be utilized in neat (100%) form or in blends with conventional diesel fuel (petrodiesel). Biodiesel has been applied as an alternative fuel in transportation trucks, farm and other off-road vehicles, automobiles, locomotives, aircraft, power generators, boilers and heaters.

The advantages and disadvantages of biodiesel as an alternative diesel fuel have been efficiently documented (Erhan et al., 2008; Graboski & McCormick, 1998; Knothe & Dunn, 2001, 2005). One major disadvantage is the performance of biodiesel in cold weather which may compromise its year-round commercial viability in moderate temperature climates. Although field studies on cold weather performance are scarce, there is evidence that soybean oil fatty acid methyl esters (SME) develop operability issues as ambient temperatures approach 0-2°C. In contrast, petrodiesel develops similar problems at a significantly lower temperature range, typically between -16 and -20°C.

This chapter examines fractionation as an effective process step that may be applied to improve the properties and performance of biodiesel and its blends in petrodiesel during cold weather. This technology is based on separating biodiesel into low- and high-melting point fractions. Unless otherwise noted, the term *alkyl esters* refers to fatty acid alkyl esters which may specifically include fatty acid methyl esters (FAME), ethyl esters, propyl esters, etc. Similarly, the term *petrodiesel* refers to petroleum middle distillate fuel, either grade No. 1 or No. 2, as defined in ASTM fuel standard D 975 (ASTM, 2008a).

2. Cold flow properties

Regardless of origin, all diesel fuels are susceptible to start-up and operability problems when vehicles and fuel systems are exposed to cold temperatures. As ambient temperatures cool toward their crystallization temperature, high-molecular weight paraffins (C₁₈-C₃₀ *n*-alkanes) in petrodiesel nucleate and form wax crystals suspended in a liquid phase

composed of shorter-chain *n*-alkanes and aromatics (Botros, 1997; Brown et al., 1989; Chandler et al., 1992; Lewtas et al., 1991; Owen & Coley, 1990). Left unattended overnight, solid wax crystals may plug or restrict flow through filters causing start-up and operability problems the next morning.

2.1 Properties of diesel fuels

At low temperatures, higher-melting point (MP) components in the fuel nucleate and grow to form solid crystals. The cloud point (CP) of the fuel is defined as the temperature where crystals become visible (diameter exceeds 0.5 μm) forming a hazy or cloudy suspension (Chandler et al., 1992; Westbrook, 2003). Prolonged exposure of the fuel to temperatures at or below CP causes crystals to grow and cling together forming agglomerates that restrict flow. Pour point (PP) is defined as the lowest temperature where the fuel flows or can be pumped (Westbrook, 2003; Westbrook & LeCren, 2003).

Both CP and PP are easily measured in the laboratory. However, neither parameter efficiently predicts how diesel fuels will perform in tanks and fuel systems during cold weather (Owen & Coley 1990; Westbrook, 2003; Westbrook & LeCren, 2003). Consequently, data from field trials were correlated to develop bench-scale tests that more effectively predict temperature limits where start-up or operability problems may be expected to occur in the fuel after prolonged exposure. The first such test, cold filter plugging point (CFPP), is accepted nearly world-wide and listed among the limiting fuel parameters in the aforementioned European biodiesel fuel standard EN 14214. CFPP is defined as the lowest temperature where 20 mL of fuel passes safely through a 45 μm wire mesh filter under 200 mm H₂O (0.019 atm) vacuum within 60 s (Westbrook, 2003).

Despite the wide acceptance of CFPP for testing cold weather performance of diesel fuels, this test does not correlate well with field test data in North America (Brown et al., 1988; Owen & Coley, 1990). Therefore, the less user-friendly low-temperature flow test (LTFT) was developed as a standard test for predicting operability of diesel fuels and fuel systems prevalent in North America (Chandler et al., 1992; McMillan & Barry, 1983). Analogous to CFPP, LTFT is defined as the lowest temperature where 180 mL of fuel passes through a 17 μm wire mesh filter under 0.2 atm vacuum within 60 s (Westbrook, 2003). The LTFT test method also requires a slower cooling rate (1°C/hr) than CFPP limiting its practicality as a bench-scale test.

2.2 Cold flow properties of biodiesel

Data in Table 1 demonstrate that CP, PP, CFPP and LTFT of biodiesel (FAME) from many lipid feedstocks are generally higher than corresponding data for petrodiesel. Cold flow properties of biodiesel generally depend on fatty acid composition. Straightforward transesterification to biodiesel does not greatly alter the fatty acid composition based in the parent feedstock. Fatty acid compositions occurring in several biodiesel feedstocks are summarized in Table 2. Shown in the bottom row of this table are MP data of the corresponding pure FAME compound.

Soybean oil-FAME (SME) generally consists of a mixture of high-melting (C₁₆ and C₁₈) and low-melting (C_{18:1}, C_{18:2} and C_{18:3}) components. A recent study (Dunn, 2010) on eight different SME products showed that for total saturated fatty acid ester concentration (ΣSats) = 14.8-19.2 mass%, CP was in the range -2.0 to 1.2°C. In contrast, tallow-FAME (TME) had ΣSats = 49.8% and CP = 14.3°C.

| Fuel | CP (°C) | PP (°C) | CFPP (°C) | LTFT (°C) | Reference |
|--------------------------|---------|---------|-----------|-----------|--|
| Canola | 0 | -9 | -7 | | Moser, 2008 |
| Coconut | 5 | -3 | | | Chiou et al., 2008 Serdari et al., 2000 |
| Corn | -3 | -4 | -7 | | Peterson et al., 2000 |
| Jatropha | 4 | 3 | 2 | | Sarin et al., 2007 |
| Olive | -2 | -3 | -6 | | Kalligeros et al., 2003 |
| Palm | 16 | 15 | 12 | | Sarin et al., 2007 |
| Rapeseed, < 5% erucic | -3 | -9 | -9 | | Rashid & Anwar, 2008 |
| Soybean | 0 | -2 | -2 | 0 | Dunn & Bagby, 1995 |
| Tallow | 17 | 15 | 9 | 20 | Foglia et al., 1997 |
| No. 1 petrodiesel | -31 | -46 | -42 | -27 | Dunn & Bagby, 1995 |
| No. 2 LSD | -16 | -27 | -18 | -14 | Dunn & Bagby, 1995 |
| No. 2 ULSD | -11 | -20 | -16 | | Unpublished data |

Table 1. Cold flow properties of fatty acid methyl esters (FAME) and petrodiesel fuels (defined according to ASTM standard D 975). CP = cloud point; PP = pour point; CFPP = cold flow plugging point; LTFT = low-temperature flow test; LSD = low-sulfur diesel (≤ 500 ppm); ULSD = ultra-low sulfur diesel (≤ 15 ppm).

The cold flow properties of biodiesel may be estimated based on Σ Sats portion of the alkyl ester mixture. The following correlation for CP was reported (Dunn et al., 1997):

$$CP = 1.44(\Sigma\text{Sats}) - 24.8 \quad (1)$$

where CP is in °C and Σ Sats is in mass%. Equation 1 is based on data correlated for Σ Sats = 6-20 mass% in SME. Although significant scatter was evident as indicated by an adjusted correlation coefficient (R^2) = 0.79, standard error of the y-estimate (σ_y) was only 2.4°C.

A more complex correlation of CP based on concentrations of the five main FAME found in SME was also reported (Davis et al., 2007). The empirical equation consisted of 21 terms with permutations of singular, squared and two-product mass fractions of each FAME. It was shown to calculate CP within $\pm 2^\circ\text{C}$ of measured values for 29 of 39 total samples.

Extrapolating Eqn. 1 to Σ Sats = 0 mass% suggests a finite minimum CP = -24.8°C ($\pm 2.4^\circ\text{C}$) for the remaining components in SME. Another recent study (Bist et al., 2009) reported a nearly linear correlation between CP and Σ Sats for FAME mixtures with Σ Sats = 2.3-15

| Oil or Fat | Fatty Acid (mass%) | | | | | | | | |
|-----------------------|--------------------|-----------------|-----------------|-----------------|-------------------|-------------------|-------------------|-------------------|-------------------|
| | C ₁₂ | C ₁₄ | C ₁₆ | C ₁₈ | C _{18:1} | C _{18:2} | C _{18:3} | C _{20:1} | C _{22:1} |
| Canola | | | 3.6 | 1.5 | 61.6 | 21.7 | 9.6 | 1.4 | 0.2 |
| Coconut ^a | 45-53 | 17-21 | 7-10 | 2-4 | 5-10 | 1-3 | ≤ 0.2 | ≤ 9.2 | |
| Corn | | ≤ 0.3 | 12-14 | 1-3 | 22-32 | 52-62 | ≤ 0.9 | | |
| Jatropha ^b | | 0.1 | 14-15 | 7 | 34-45 | 31-43 | 0.2 | | |
| Olive | | | 10.5 | 2.6 | 76.9 | 7.5 | | | |
| Palm ^c | 0.2 | 1.1 | 44.1 | 4.4 | 39.0 | 10.6 | 0.3 | | |
| Rapeseed | | | 4 | 1 | 14.8 | 14.2 | 9.1 | 10 | 45.1 |
| Soybean | | | 2-13 | 2-6 | 18-31 | 49-57 | 2-11 | | ≤ 0.3 |
| Tallow | | 3.4 | 29.5 | 26 | 34.9 | 1.5 | | | |
| FAME MP (°C) | 4.3 | 18.1 | 28.5 | 37.7 | -20.2 | -43.1 | -55.5 | -7.8 | -3.0 |

^aCoconut oil also contains 4-9% C₈ (octanoic acid), 5-8% C₁₀ (decanoic acid), and ≤ 0.2% C₂₀ (arachidic acid).

^bJatropha oil also contains 0.1% C₁₀, 0.2-0.3% C₂₀ and ≤ 0.2% C₂₂ (behenic acid).

^cPalm oil also contains 0.2% C₂₀.

Table 2. Fatty acid composition of biodiesel feedstock lipids and melting points (MP) of corresponding FAME. Sources: Fatty acid profile data from Knothe et al., 2010 & references therein; MP data from Knothe & Dunn, 2009 except for C_{18:3} (unpublished data). C₁₂ = Dodecanoic acid; C₁₄ = myristic acid; C₁₆ = palmitic acid; C₁₈ = stearic acid; C_{18:1} = oleic acid; C_{18:2} = linoleic acid; C_{18:3} = linolenic acid; C_{20:1} = eicosenoic acid; C_{22:1} = erucic acid.

mass%. However, this study showed that decreasing Σ Sats below 2.3 mass% resulted in sharp non-linear decreases in CP. This suggested that accurate calculation of CP depended on factors other than Σ Sats in a FAME mixture.

The following correlation was reported for calculating CFPP as a function of Σ Sats based on studies conducted on used cooking oil-FAME (UCOME):

$$\text{CFPP} = 0.99(\Sigma\text{Sats}) - 19.0 \quad (2)$$

for Σ Sats = 14-26 mass% (González Gómez et al., 2002). This equation was nearly linear with respect to $R^2 = 0.95$. The following correlation based on cold flow properties of admixtures of SME and FAME from palm, canola and high-oleic sunflowerseed oils was similarly reported:

$$\text{CFPP} = 0.438(\Sigma\text{Sats}) - 8.93 \quad (3)$$

for Σ Sats up to 48.2 mass% (Moser, 2008). This equation had $R^2 = 0.86$ and relatively high degrees of scatter were observed at lower concentrations. For Σ Sats exceeding 12 mass%, R^2 increased to 0.98.

In contrast, a curvilinear relationship was reported for CFPP increasing from -12 to +12°C as Σ Sats in biodiesel increased from 5 to 45 mass% (Hilber et al., 2006). This study also noted that CFPP of biodiesel derived from animal fats generally exceeds 0°C. Similar results were obtained by correlating CFPP with respect to Σ Sats for blends of SME and FAME derived from rapeseed and palm oils (Park et al., 2008). Results indicated a higher degree of scatter and a sharp negative slope as unsaturated FAME content exceeded 85%.

2.3 Cold flow property correlations

A recent survey (Dunn & Moser, 2010) was conducted on cold flow properties of neat (100%) biodiesel derived from a variety of vegetable and plant oil, animal fat, used cooking oil, waste grease and other lipid feedstocks. Least-squares linear regression analysis were applied to PP, CFPP and LTFT versus CP of the corresponding biodiesel fuel. The following three correlations were reported:

$$PP = 0.98(CP) - 5.1 \quad (4)$$

$$CFPP = 1.0(CP) - 4.5 \quad (5)$$

$$LTFT = 1.0(CP) + 5 \quad (6)$$

where CP, PP, CFPP and LTFT are in °C. These equations had $R^2 = 0.73, 0.78$ and 0.54 indicating significant scatter in the data and σ_y were between 3.4 and 4.4. Slopes were close to unity suggesting PP, CFPP and LTFT may be estimated by only measuring CP of the fuel.

2.4 Biodiesel/Petrodiesel blends

A detailed discussion on the cold flow properties of biodiesel/petrodiesel blends is presented elsewhere (Dunn & Moser, 2010). Summarizing, CP and PP curves generally show an increase with respect to increasing blend ratio (defined as vol% biodiesel in the blend). This was true for blends in No. 2 low-sulfur petrodiesel ($S \leq 500$ ppm) and ultra-low sulfur petrodiesel (ULSD; $S \leq 15$ ppm) as well as blends in jet fuel and No. 1 petrodiesel (kerosine). Cold flow properties of several biodiesel/petrodiesel blends are summarized in Table 3.

For blends shown in Table 3, ratios are defined as the vol% biodiesel in the blend and denoted as 'Bx' where x refers to the vol% biodiesel. Compared with corresponding data in Table 1, biodiesel/petrodiesel blends tend to yield cold flow properties that are close to volumetric average values based on blend ratio. At blend ratios as low as B20-B30, much of the influence of biodiesel on cold flow properties is minimized by dilution with petrodiesel. Consequently, blending biodiesel with petrodiesel may be advantageous for mitigating the poor cold flow properties of biodiesel from many lipid feedstocks. On the other hand, blending at higher ratios may compromise cold flow properties.

The aforementioned survey on cold flow properties of biodiesel derived from a variety of lipid feedstocks was also extended to compare properties of biodiesel/petrodiesel blends (Dunn & Moser, 2010). Similar to equations discussed earlier for neat (unblended) biodiesel, PP, CFPP and LTFT were found to correlate with CP as shown in the following equations:

$$PP = 1.10(CP) - 5.5 \quad (7)$$

$$CFPP = 0.95(CP) - 4.3 \quad (8)$$

| Oil or Fat (FAME) | Petrodiesel | CP (°C) | PP (°C) | CFPP (°C) | LTFT (°C) | Reference |
|-------------------|-------------|---------|---------|-----------|-----------|---------------------|
| Soybean oil | No. 1 | -17 | -30 | -27 | -19 | Dunn & Bagby, 1995 |
| Chicken fat | No. 2 LSD | -10 | -14 | | | Wyatt et al., 2005 |
| Chicken fat | No. 2 ULSD | -9 | -10 | -14 | | Unpublished data |
| Palm oil | Winter ULSD | -2 | -16 | -6 | | Tang et al., 2008 |
| Soybean oil | No. 2 LSD | -14 | -21 | -14 | -12 | Dunn & Bagby, 1995 |
| Soybean oil | No. 2 ULSD | -11 | -17 | -14 | | Unpublished data |
| Tallow | No. 2 LSD | -5 | -9 | -8 | | Foglia et al., 1997 |
| Used Cooking Oil | No. 2 ULSD | -10 | -13 | -15 | | Unpublished data |
| Waste Grease | Winter ULSD | -17 | -24 | -24 | | Tang et al., 2008 |

Table 3. Cold flow properties of biodiesel/petrodiesel blends. Blend ratio = B20 (20 vol% biodiesel in blend). FAME = fatty acid methyl esters; LSD = low-sulfur petrodiesel ($S \leq 500$ ppm); ULSD = No. 2 ultra-low sulfur petrodiesel ($S \leq 15$ ppm); Winter ULSD = blend of No. 1 and No. 2 grade ULSD.

$$LTFT = 1.10(CP) + 3.3 \quad (9)$$

where CP, PP, CFPP and LTFT are in °C. These equations were nearly linear with respect to $R^2 = 0.90, 0.92$ and 0.94 , respectively, and σ_y were between 3.3 and 4.0. Comparing with corresponding Eqns. 4-6, intercepts deviated by less than 2.0 and slopes by less than 0.12, suggesting the Eqns. 7-9 may be applied to blends with very low biodiesel blend ratios. Slopes for Eqns. 7-9 were also close to unity suggesting PP, CFPP and LTFT may be estimated by only directly measuring only CP. Overall, results from the survey showed that biodiesel has a predominant role in determining the cold flow properties and performance in blends with petrodiesel.

3. Thermodynamics of crystallization

Biodiesel is essentially a mixture of fatty acid alkyl ester components. For example, as shown in Table 2, SME is a mixture of methyl esters of C_{16} , C_{18} , $C_{18:1}$, $C_{18:2}$ and $C_{18:3}$ fatty acids. Thermodynamic contributions related to alkyl ester composition may be accounted for by applying freezing point depression theory.

Crystallization phase behavior in model lipid mixtures was studied by application of the Hildebrand equation to results from isothermal and non-isothermal DSC analyses (Toro-Vazquez et al., 2000; Zhou & Hartel, 2006). Both studies employed the form of the equation for ideal mixtures, shown as follows:

$$\ln(x) = -\frac{\Delta H_{\text{fus}}}{R_g} \left[\frac{1}{T_f} - \frac{1}{\text{MP}} \right] \quad (10)$$

where the mole fraction of crystallized fat (x) is a function of its enthalpy of fusion or melting (ΔH_{fus}), the gas constant (R_g), its crystallization onset temperature (T_f) in a mixture and its MP in pure form.

Phase behavior resembling freezing point depression was observed in dewaxed gas oil spiked with pairs of long-chain (C_{20} - C_{28}) n -alkanes (Holder & Winkler, 1965). Freezing point depression theory accurately predicted the cold flow behavior of mixtures by following crystallization behavior of a binary system in a solvent that did not freeze at the temperatures studied. The theory also explained how small mass fractions of heavy wax can disproportionately influence cold flow properties of mixtures.

Another study (Suppes et al., 2000) examined several theoretical and empirical models for mixtures composed of n -alkanes, olefins and other hydrocarbons and determined that freezing point depression was the only fundamentally correct theory for describing crystallization processes in organic liquid mixtures. One equation derived for mixtures where independent crystallization of solute species is prevalent was as follows:

$$\ln(\gamma_i x_i) = -\frac{\Delta H_{\text{fus}}}{R_g} \left[\frac{1}{T_f} - \frac{1}{\text{MP}} \right] - \frac{\Delta C_p}{R_g} \left[1 - \frac{\text{MP}}{T_f} + \ln\left(\frac{\text{MP}}{T_f}\right) \right] \quad (11)$$

where γ_i and x_i are activity coefficient and mole fraction of component 'i' in the liquid phase, ΔH_{fus} , MP and T_f are parameters for component 'i' as defined in Eqn. 10 and ΔC_p is the differential heat capacity of species 'i' between liquid and solid phases ($C_p^L - C_p^S$). The activity coefficient accounts for non-ideal behavior in the liquid phase, while the second term on the right-hand-side corrects for variation in ΔH_{fus} with respect to temperature. Another form of Eqn. 11 was derived for mixtures where a solid solution forms upon crystallization. This equation replaces the left-hand side with the term $\ln([\gamma_i x_i]/[\gamma_i^S x_i^S])$, where γ_i^S and x_i^S are activity coefficient and mole fraction of species 'i' in the solid phase.

Equation 10 was applied to determine CP of biodiesel based on studies with mixtures of long-chain (C_{16} - C_{18}) FAME (Imahara et al., 2006). This model was derived by setting $\gamma_i = 1$ due low ambient pressure and assuming ΔC_p as shown in Eqn. 11 was negligible. FAME mixtures showed good agreement between corresponding T_f and CP data. Eutectic points were predicted for mixtures with methyl palmitate (C_{16})/stearate (C_{18}) mole ratios of 2.3:1. Similar observations were noted for mixtures of methyl palmitate with dodecanoate (C_{12}) and myristate (C_{14}). Deviations between T_f and measured CP data were less than 5°C for mixtures with up to five FAME. Results also demonstrated that T_f was independent of the species of unsaturated FAME in the solvent phase.

A recent study (Dunn, 2008) compared results from application of Eqns. 10 and 11 to model crystallization of methyl palmitate and stearate in solutions with methyl oleate ($C_{18:1}$). MP and ΔH_{fus} values for pure FAME components were measured by DSC. Results for binary

mixtures indicated non-ideal behavior with respect to high-MP solutes, in contrast to results reported by Imahara et al. (2006). Osmotic coefficient data indicated that the methyl oleate behaved independently of the type of solute in the liquid phase (Dunn, 2008). The ΔC_p term in the right-hand side of Eqn. 11 was not significant in calculation of T_f values. Results for ternary mixtures indicated a eutectic point at C_{16}/C_{18} mole ratio of 3.1:1. Although deviations between calculated and measured T_f values averaged less than 2.3°C, larger deviations occurred at C_{16}/C_{18} mole ratios close to the eutectic point, suggesting that methyl palmitate and stearate did not undergo independent crystallization under these conditions. Calculated results were generally more accurate when accounting for non-ideal behavior in the liquid phase. Adding *n*-propyl, isopropyl or *n*-butyl stearate also disrupted independent crystallization of solute species in ternary mixtures with methyl stearate and oleate (Dunn, 2009).

4. Improving the cold flow properties of biodiesel

Results from the aforementioned cold flow property survey (Dunn & Moser, 2010) generally agreed with conclusions reported in earlier research studies (Dunn & Bagby, 1995, 1996; Dunn et al., 1996) on developing approaches to reduce CP, PP, CFPP and LTFT of biodiesel. The main conclusion based on correlations shown in Eqns. 8 and 9 was that approaches that emphasize reducing the CP of biodiesel will have the greatest potential for improving CFPP and LTFT. In addition, improving the properties of biodiesel will have the added benefit of improving the properties of its blends with petrodiesel.

As discussed earlier, blending with petrodiesel at relatively low blend ratio mitigates most performance-related issues with cold flow properties of neat biodiesel depending on its original feedstock. Splash blending biodiesel and petrodiesel may also present problems during cold weather. A recent report (Cold Flow Blending Consortium, 2005) recommended that biodiesel be stored at temperatures no lower than 6°C above its CP before splash blending with petrodiesel. Increased reliance on palm oil, tallow and other feedstocks with relatively high $\Sigma Sats$ (see Table 2) continues to drive research efforts to improve cold flow properties. Another driver may be applications where higher blend ratios are necessary to improve exhaust emissions from combustion of fuels formulated with biodiesel.

A comprehensive discussion on experimental approaches evaluated for improving the performance of biodiesel and its blends is presented elsewhere (Dunn & Moser, 2010). Summarizing, these approaches include:

1. Treating with commercial petrodiesel cold flow improver additives
2. Developing new additives for biodiesel
3. Mixing FAME with alkyl esters made from transesterification with medium- and branched-chain alcohols
4. Decreasing crystallization temperature (T_f) by reducing total saturated FAME concentration.

The remainder of this chapter is an in depth examination of fractionation technologies that have or may be explored to address the fourth outlined approach.

5. Fractionation

The objective of fractionation is to modify the fatty acid alkyl ester composition of biodiesel such that the concentration of high-MP components decreases. *Crystallization fractionation* takes advantage of the aspect that saturated alkyl esters have a significantly higher MP than

unsaturated alkyl esters with the same chain length. For example, MP data in Table 2 show values of 37.7°C for methyl stearate (C₁₈) and -20.2°C for methyl oleate (C_{18:1}). With few exceptions biodiesel from most lipid feedstocks is composed of saturated and unsaturated long-chain (C₁₄-C₁₈) fatty acid alkyl esters where higher-melting components have MP at least 38°C higher than lower-melting components. This large differential means a mixture would typically experience nucleation and crystal growth kinetics similar to precipitation of solutes (MP > 18.1°C) from a solvent mixture (MP < -20°C). Applying this paradigm to multi-component alkyl ester mixtures suggests that an effective approach for improving cold flow properties is to separate and remove the high-MP components from the mixture.

Commercial fractionation processes for application to edible oils and fats have been extensively reviewed (Anderson, 1996; Bailey, 1950; Illingworth, 2002; Kellens & Hendrix, 2000; Kellens et al., 2007; Krishnamurthy & Kellens, 1996; O'Brien, 1998; Rajah, 1996). One popular process is crystallization fractionation which separates lipid components based on differences in crystallizing temperatures (MP). Crystallization fractionation has been successfully applied to vegetable oils, hydrogenated vegetable oils, animal fats, fish oils, fatty acids, fatty acid esters, monoacylglycerols, diacylglycerols and other fatty derivatives (Brown & Kolb, 1955; Illingworth, 2002; Kellens & Hendrix, 2000; O'Brien, 1998).

The traditional process is performed in two steps, crystallization followed by separation into liquid and solid fractions. Product yield is defined by separation of high- and low-melting fractions and depends on maintaining strict control during both steps of the process. In the first step, the oil is cooled at a controlled rate with gentle agitation in a chiller (or crystallizer) to promote selective nucleation and crystal growth. Cooling rate in the chiller must be constantly monitored because it determines the rate of nucleation and number, size distribution and shape of the crystals. Crystallization modifiers may be added to promote nucleation, modify crystal growth rate and habit or reduce entrainment of liquid within solid crystal agglomerates (Illingworth, 2002; Krishnamurthy & Kellens, 1996). Agitation regulates crystalline growth by reducing buildup of heat transfer-reducing crystals on walls of the chiller and agglomeration of small crystals which causes entrainment of liquid phase. Agitation also reduces the effects of increasing viscosity that occur during the cooling cycle. Increasing viscosity decreases mass transfer rate to the crystal surface and reduces heat transfer away from the crystals (Krishnamurthy & Kellens, 1996). It must be tightly controlled to prevent detrimental effects of high shear rates, which can fragment or destroy crystals, and limit addition of mechanical work to the system (Anderson, 1996; Krishnamurthy & Kellens, 1996). Other process variables include composition of source oil or fat, final crystallization temperature and total time in the chiller. The latter two variables will also significantly affect crystalline growth rates (Illingworth, 2002; Kellens & Hendrix, 2000).

Once well-defined crystals with narrow size distribution and specified shape are formed, the resulting slurry is transferred to the second step for separation. Separation of solid and liquid phases is usually performed by filtration, centrifugation or decantation. Most commercial filtration equipment employs plate and frame, flat-bed vacuum band, rotary drum vacuum, membrane (polypropylene or synthetic rubber), hydraulic press or pressure leaf type filters. Conditions are also tightly controlled and generally determine optimal crystal sizes that should be generated in the crystallization stage (Illingworth, 2002; Krishnamurthy & Kellens, 1996).

5.1 Dry fractionation

Dry (melt) fractionation, defined as crystallization from a melt without dilution in solvent, is the simplest, least expensive and most common process for separating high- and low-

melting fatty derivatives (Anderson, 1996; O'Brien, 1998). Dewaxing and winterization are limited forms of dry fractionation often associated with oil refining because the total wax content removed is relatively small (< 2 mass%) and physical properties other than appearance are not affected. Winterization is typically associated with crystallization during long-term storage in cold temperatures. Dry fractionation generally refers to a modification process where substantial changes in composition are accompanied by significantly modified CP, MP, cold stability test, dropping point and iodine value. Crystallization and separation stages are technologically sophisticated and require a higher degree of control to separate fatty derivatives with higher selectivity than dewaxing or winterization (Kellens & Hendrix, 2000; Krishnamurthy & Kellens, 1996).

Cold flow properties of liquid fractions obtained from dry fractionation of SME and UCOME are summarized in Table 4. Earlier studies (Dunn et al., 1996, 1997) showed that dry fractionation of SME decreased CP to -20°C and LTFT to -16°C, values that compared well to the properties of low sulfur No. 2 petrodiesel. PP and CFPP were also significantly reduced. Although Σ Sats decreased to as low as 5.6 mass%, liquid fraction yields were only 25-33 mass% relative to the starting material. Step-wise crystallization in 2-3°C-increments was necessary to maintain control over crystallization. Residence time in the cooling bath for each step was 16 h (overnight).

| FAME | Modifier | Steps | T _B (°C) | Yield (g/g) | Σ Sats (mass%) | CP (°C) | PP (°C) | CFPP (°C) |
|--------|-------------------------------|-------|------------------------|----------------|--------------------------|--------------------|------------|--------------|
| SME | None | 6 | -10 | 0.334 | 6.3 | -20 | -21 | -19 |
| SME | None | 11 | -10.0 | 0.255 | 5.5 | -7.1 ^a | | |
| LP-SME | None | 7 | -13.2 | 0.857 | 3.8 | -11.2 ^a | | |
| UCOME | None | 1 | 0 | 0.30 | 13.0 | | | -5 |
| UCOME | None | 1 | -6 | NR | 9.6 | | | -9 |
| SME | <i>DFI-200^b</i> | 6 | -10 | 0.801 | 9.8 | -11 | | -12 |
| SME | <i>Winterflow^b</i> | 6 | -10 | 0.870 | 9.3 | -11 | | -11 |

^aCrystallization onset temperature from differential scanning calorimetry analysis.

^bPetrodiesel pour point depressants, 2000 ppm. Vendors: Du Pont (*DFI-200*) and Octel-Starreon (*Winterflow*).

Table 4. Cold flow properties of dry fractionated biodiesel. Sources: Dunn, 1998; Dunn et al., 1997; González Gómez et al., 2002; Kerschbaum et al., 2008; Lee et al., 1996. T_B = Coolant bath temperature (final step); Yield = mass ratio liquid fraction/starting material; Σ Sats = total saturated alkyl concentration; SME = soybean oil-FAME; LP-SME = low-palmitic (4.0 mass%) SME.

The effects of dry fraction on cold flow properties of "normal" and low-palmitic (4.0 mass%) SME were investigated (Lee et al., 1996). Dry fractionation of normal SME was conducted by step-wise crystallization with incremental residence times varying with respect to time required for significant crystal formation to occur. Typical liquid fraction yields for each

step were 84-90 mass%. After 11 steps and a total residence time of 84 h, the final liquid fraction had $\Sigma\text{Sats} = 5.5$ mass% and crystallization onset temperature = -7.1°C (measured by differential scanning calorimetry), compared to values of 15.6 mass% and $+3.7^\circ\text{C}$ for non-fractionated SME. However, final liquid yield was only 25.5%. Fractionation of low-palmitic SME under similar conditions required seven steps and increased liquid yield to 85.7%. The liquid fraction had $\Sigma\text{Sats} = 3.8$ mass% and onset temperature = -11.2°C compared to values of 6.8 mass% and -3.7°C for the non-fractionated low-palmitic SME. Comparing results from these two studies, the former employed a constant crystallization time (16 h) for each fractionation step (Dunn et al., 1996, 1997) while the latter increased control of nucleation and crystal growth by keeping the crystallized mass constant for each step (Lee et al., 1996). Both schemes collected liquid fractions with significantly improved cold flow properties at the expense of poor liquid fraction yields for normal SME. Trapping of liquid within solid crystals during growth and agglomeration phases led to substantial losses of liquid after filtration. Contrasting the control schemes also suggests the rate of crystalline growth and agglomeration was rapid causing substantial entrainment of liquid phase during early stages of crystallization.

Results from two studies applying dry fractionation to decrease CFPP of UCOME are also shown in Table 4. One study (González Gómez et al., 2002) cooled the liquid UCOME to 0°C at a slow cooling rate ($0.1^\circ\text{C}/\text{min}$) for 15-24 h. After filtration, ΣSats decreased to 13.0 mass% and CFPP to -5°C , compared to values of 19.2 mass% and -1°C for non-fractionated UCOME. Liquid fraction yields were poor at 30%. The second study (Kerschbaum et al., 2008) circulated UCOME through a cross-flow micro heat exchanger (channel diameter = $200\ \mu\text{m}$) while slowly decreasing the temperature of water-ethylene glycol coolant flowing through other channel. Employing a very slow cooling curve over a period of 8 days reduced ΣSat by 11.4 mass% and CFPP by 11°C , compared to non-fractionated UCOME. Animal fat-FAME and UCOME were dry fractionated with separation mainly occurring between saturated and unsaturated FAME (Falk & Meyer-Pittroff, 2004). Oils were first cooled in a flask until large crystal structures formed and the solid phase removed by filtration through a $300\ \mu\text{m}$ pore-size filter and centrifugation at $1200 \times g$. Dry fractionation of TME under controlled conditions resulted in 60-65% yields of liquid fraction characterized by an increase in iodine value from 41 to 60 and a decrease in CP from 11 to -1°C (Krishnamurthy & Kellens, 1996).

A pilot-scale process study (Delafontaine et al., 2005) demonstrated that SME could be fractionated in a scraped-surface heat exchanger operating in continuous mode. The heat exchanger operated with efficient heat transfer and during trials retention times were less than 60 min. The biodiesel was pre-chilled to 10°C before being pumped into the heat exchanger and steady state crystallization occurred at -3°C within the exchanger. A light-scattering probe in the collection vessel confirmed the slurry consisted of near-Gaussian distribution about a median crystal size of $15\ \mu\text{m}$. Filtrate temperatures were as low as -4.6°C before the product began to gel. Pumping the slurry through a membrane press filter at a rate of $4\ \text{L}/\text{min}$, CP of the filtrate was only 1.2°C , suggesting this step may be insufficient to maintain good separation between fractions.

5.2 Wax crystallization modifiers

Crystallization modifiers may be applied to promote nucleation or adsorb onto crystal surfaces (co-crystallization) to disrupt otherwise orderly patterns and limit growth and agglomeration. Modifiers can improve separation efficiency and reduce entrainment by

slowing the rate of agglomeration. Examples of modifiers for fatty derivatives include commercial lecithins, monoacylglycerols, diacylglycerols, citric acid esters of monoacylglycerols and diacylglycerols, free fatty acids and fatty acid esters of sorbitol and polyglycerol (Illingworth, 2002; Krishnamurthy & Kellens, 1996).

An earlier study (Dunn et al., 1996) reported that a number of commercial petrodiesel cold flow improver additives also significantly reduced PP and CFPP of neat SME. It was concluded that these additives decreased the rates of crystalline growth and agglomeration at temperatures below the CP of SME. Two of the most effective additives, *DFI-200* and *Winterflow*, were subsequently evaluated as crystallization modifiers for dry fractionation of SME in another study (Dunn et al., 1997). Some results from the second study are summarized in Table 4.

Results from the step-wise fractionation of SME treated with 2000 ppm *DFI-200* and *Winterflow* additives are shown in Table 4. Six incremental crystallization-filtration cycles were conducted on succeeding liquid fractions as coolant temperature for each step decreased by 2-3°C. The additives significantly increased final liquid fraction yields to 80-87 mass%. Both trials resulted in decreasing CP to -11°C, a value close to the final cooling bath temperature (-10°C). These results demonstrated that treating biodiesel with crystallization modifiers hindered growth and agglomeration of crystals which subsequently reduced entrainment of liquid within the solid crystal phase. These conditions improved separation efficiencies leading to significant increases in liquid fraction yield (Dunn et al., 1997).

5.3 Solvent fractionation

Crystallization fractionation from dilute solution in organic solvent offers many advantages over dry fractionation. Solvent fractionation reduces viscosity and entrainment of liquid within and between solid crystals. The process is characterized by short crystallization time and ease of filterability leading to high separation efficiency and improved yield. It is the most efficient fractionation process, though it may raise concerns associated with safety, handling and recovery of solvent. Decontaminating fractions from trace concentrations of residual solvent may also prove difficult and problematic. It is more expensive than dry fractionation and generally employed in production of high quality oils or fats or products with unique properties (Illingworth, 2002; Krishnamurthy & Kellens, 1996; O'Brien, 1998).

Factors affecting solvent selection include polarity, relative solubility of components to be fractionated and the presence of unsaturated fatty acids. Solvent polarity affects crystal morphology which influences growth rate and habit (Gunstone, 1967; Larsson & Quinn, 1994). Alkyl esters have higher solubility in a given organic solvent than corresponding free fatty acids and will require much lower crystallization temperatures. Acetone, methanol, Skellysolve B and ether have been employed as solvents for fractionation of alkyl esters from cottonseed and soybean oils and other long-chain (C₁₈) fatty acids (Brown & Kolb, 1955). Other solvents employed in fractionation of lipids include, chloroform, ethanol (95%), ethyl acetate, hexane, isopropanol, methanol and 2-nitropropane (Brown & Kolb, 1955; Krishnamurthy & Kellens, 1996; O'Brien, 1998).

Cold flow properties of liquid fractions obtained from solvent fractionation of SME in hexane and isopropanol are summarized in Table 5. An earlier study (Dunn et al., 1997) investigated effects of hexane and isopropanol on crystallization fractionation of SME. Fractionation was achieved in one step with crystallization times of 3.5-5 h. As shown in

Table 5, fractionation from hexane at -25°C resulted in a liquid fraction with $\text{CP} = -10^{\circ}\text{C}$. Although yield improved to 78.4 mass% with respect to dry fractionation (see Table 4), ΣSats in the liquid fraction decreased by only 3.5 mass% compared to non-fractionated SME. This suggested its CP may have been influenced by residual hexane left behind after evaporation of the solvent. Decreasing crystallization temperature to -30°C reduced ΣSats in the liquid fraction to 11.3 mass% allowing reduction in CP to -10°C and PP to -11°C . However, liquid product yield decreased to 59.6%. Fractionation of SME from isopropanol at -15°C resulted in comparable results after only one step. Product yield was 86.0% and ΣSats was 10.8 mass%, resulting in significant decreases in CP, PP and CFPP as shown in Table 5.

| Solvent | SME/Solvent (g/g) | Steps | T_B ($^{\circ}\text{C}$) | Yield (g/g) | ΣSats (mass%) | CP ($^{\circ}\text{C}$) | PP ($^{\circ}\text{C}$) | CFPP ($^{\circ}\text{C}$) |
|-------------|--------------------|-------|------------------------------|-------------|-----------------------------|---------------------------|---------------------------|-----------------------------|
| Hexane | 0.284 | 1 | -25 | 0.784 | 16.2 | -10 | -11 | -10 |
| Hexane | 0.217 ^a | 3 | -28.4 | 0.77 | 6.0 | -5.8 ^b | | |
| Isopropanol | 0.228 | 1 | -15 | 0.860 | 10.8 | -9 | -9 | -9 |

^aIn g/mL.

^bCrystallization onset temperature from differential scanning calorimetry analysis.

Table 5. Cold flow properties of solvent fractionated soybean oil-FAME (SME). Sources: Dunn, 1998; Dunn et al., 1997; Lee et al., 1996.

Similarly, fractionation of SME from hexane solvent in three steps was evaluated (Lee et al., 1996). Crystallization times were 16, 16 and 5 h, respectively, and the final cooling temperature was -28.4°C . The final liquid fraction yield increased significantly to 77 mass% compared to dry fractionation of SME (see Table 4). The liquid fraction had $\Sigma\text{Sats} = 6.0$ mass% and an crystallization onset temperature = -5.8°C (measured by differential scanning calorimetry). Results also showed the importance of the nature of the solvent. Dilution in methanol resulted in separation into two liquid layers as coolant temperature approached -1.6°C . Acetone mixtures resulted in no significant reduction in onset temperature and crystals failed to form in mixtures with chloroform at cooling temperatures below -25°C .

Crystallization of TME in blends with ethanol, No. 2 petrodiesel and ethanol/No. 2 petrodiesel solvents was investigated (Hanna et al., 1996). Experimental procedures closely resembled traditional winterization where samples were stored for three weeks in walk-in freezers for a series of incremental crystallization/filtration steps performed at 10, 0, -5, -10 and -16°C . Ethanol decreased formation of crystals in TME and TME/No. 2 petrodiesel mixtures. Winterization of 1:9 (vol) TME/No. 2 petrodiesel and 16.5:13.5:70 (vol) TME/ethanol/No. 2 petrodiesel mixtures reduced CP below -5°C .

Effects of adding wax crystallization modifiers on fractionation of SME diluted in hexane and isopropanol were investigated (Dunn et al., 1997). *DFI-200* and *Winterflow* at 2000 ppm concentration (in SME) were added to 0.20 g/g SME/solvent mixtures and processed in one step. Compared to mixtures without modifiers, lower cooling bath temperatures were necessary to promote shorter crystallization times. Liquid fractions were collected in very high yield (95-103 mass%), indicating that residual solvent was likely retained following

evaporation. Results from these trials were compared to those for solvent fractionation of SME with no modifiers present (see Table 5). For mixtures with modifiers, liquid fractions from SME/isopropanol had slightly higher Σ Sats (12.8-13.3 mass%) than those for mixtures without modifiers. Liquid fractions from mixtures with modifiers had higher CP (-6 to -5°C) while PP was in the same range (-12 to -9°C) as those from mixtures without modifiers present. It was concluded that adding crystallization modifiers offered no significant advantages in performing solvent fractionation on SME.

5.4 Urea fractionation

Clathrates are well-defined addition compounds formed by inclusion of *guest* molecules within cavities formed by crystal lattices or present between large molecules. Urea inclusion compounds (UIC) were discovered by accident in 1940. While studying the effects of urea on pasteurized milk, it was shown that urea formed solid crystals when mixed with *n*-octanol (Hayes, 2002). This work reported that *n*-alkanes, *n*-alcohols, fatty acids, fatty acid esters, aldehydes and ketones demonstrated formation of UIC. It was subsequently shown that UIC readily form with straight-chain guest molecules having six or more carbon atoms in length with stability of the clathrates increasing with increasing chain-length. In contrast, molecules with less than six carbon atoms or with branched or cyclic moieties in their structure formed less stable clathrates when mixed with urea (Bengen & Schlenk, 1949; Hayes, 2002; Schlenk, 1954). Furthermore, increasing the degree of unsaturation, particularly with respect to *cis*-type double bonds, in fatty acids and esters also decreases the tendency to form stable UIC (Abu-Nasr et al. 1954; Domart et al., 1955; Newey et al. 1950; Schlenk & Holman, 1950; Swern & Parker, 1952a, 1952b, 1953). These early findings suggested that processes for separating mixtures of organic compounds with high degrees of selectivity could be based on their tendencies to form clathrates when mixed with urea.

5.4.1 Theory and methodology

The theory of UIC-based fractionation summarized herein is explained more thoroughly in other reviews (Hayes, 2002; Schlenk, 1954; Swern, 1955). Urea clathrates do not form unless guest molecules are present. Clathrates consist of a series of parallel channels approximately 55-58 nm in average inside diameter. Urea molecules ($\text{H}_2\text{N}-[\text{CO}]-\text{NH}_2$) are aligned along the channel walls and held in place by hydrogen bonding. Clathrates form needle-like hexagonal crystals with channels aligned side-by-side in contrast to the tetragonal crystalline structures formed from pure urea. These channel walls are considered smooth such that guest molecules with sufficiently small cross-sectional diameter will randomly pack inside them.

In practice, UIC are prepared by dissolving urea and guest compounds into solution typically at elevated temperature and in presence of a polar solvent that does not form clathrates (for example, methanol or ethanol) then cooling the resulting heterogeneous solution until solid crystals appear. Operational conditions depend on solubility of compounds being studied and desired yield and fractionation efficiency of the intended products. Presence of UIC in solid phases may be confirmed analytically by X-ray diffraction, differential scanning calorimetry or infrared spectroscopy.

Solid (UIC) and liquid phases are typically separated by vacuum filtration. If fractionated molecules within the UIC are to be recovered, adding slightly acidic (pH = 3-4) warm water dissolves urea leaving a separate solid precipitate or liquid layer that can subsequently be vacuum-distilled to remove traces of organic solvent. Alternatively, guest molecules may be

extracted with a solvent such as benzene, isooctane or carbon tetrachloride. Similar process steps are applied when fraction(s) of interest remain in the filtrate (liquid phase) after separation. Urea and organic solvents employed in the fractionation steps may be recovered and recycled within the process.

5.4.2 Applications

Urea clathrates were initially applied in fractionation of petroleum based on MP of *n*-alkanes present in the oil. However, availability of inexpensive petroleum allowed less complex distillation refining, hindering progress in the development of UIC methodologies. Nevertheless, at least one recent study (Zabarnick et al., 2002) demonstrated that urea fractionation significantly reduces CP, PP and freezing point of Jet-A aviation fuel. The best results were obtained by forming a slurry where Jet-A fuel is mixed with 25 mass% urea and 1 mass% methanol at 23°C for 3 h. Results indicated substantial decreases in concentration of *n*-tetradecane (C₁₄) and higher *n*-alkanes in the filtrate after passing the slurry through a chromatographic syringe.

Urea clathrates were also demonstrated to form for several common saturated fatty acids as well as alkyl esters of myristic, palmitic and stearic acids. Microscopic examination shows that UIC formed with saturated fatty acids and esters appear as thin or coarse needles. In contrast, unsaturated fatty acids and esters formed flat hexagonal leaflets. Formation of UIC is an exothermic process where guest molecules that more readily form clathrates have higher molar heats of formation. Increasing chain length or decreasing the degree of unsaturation generally increases molar heat of formation. Mostly owing to hydrogen bonding, fatty acids have higher molar heats of formation than fatty esters (Schlenk, 1954).

Urea binds with fatty acids or esters at a mass ratio of 3:1, though it is often necessary to add excess urea to obtain good yields. For example, 1 g fatty derivative dissolved in a hot mixture of 30 mL methanol plus 5 g urea (solubility limit at room temperature) forms precipitates when cooled to room temperature. Temperatures and concentrations may be varied for guest molecules with lower tendencies to form clathrates such as unsaturated fatty esters. Fatty acid or alkyl ester mixtures may be fractionated into saturated and unsaturated components after one urea precipitation step. However, for mixtures of palmitic, stearic, oleic, linoleic and linolenic acids or esters, separation is generally most efficient between saturated/monounsaturated and polyunsaturated components. Also, increasing urea concentration generally increases the concentration of oleic acid or ester contained within the clathrates (Schlenk, 1954).

Initially, applications that were explored for UIC processing in the field of fats and oils chemistry were removal of free fatty acids from plant oils and fats and fractionation of fatty acids, esters, alcohols and other derivatives. Taking advantage of UIC not oxidizing when exposed to air, storage of polyunsaturated fatty materials as UIC solids was explored. Finally, isolation of fatty peroxides and determining the configuration of diastereoisomers (for example, 9,10-dihydroxystearic acid) by formation of clathrates were also studied (Swern, 1955).

More recently, urea fractionation was applied in laboratory- and industrial-scale reduction of saturated fatty acid content of low-erucic acid rapeseed oil (Hayes et al., 1998). UIC were employed in fractionation of fatty acid mixtures of marine, borage, canola, linseed, lesquerella, rapeseed and meadowfoam oils (Hayes et al., 2000; Hayes, 2006). This technique was applied in isolation and purification of linoleic acid from sunflowerseed oil (Wu et al., 2008) and oleic and linoleic acids from various vegetable oils (Lee, 2003). Urea fractionation

was utilized in selective enrichment of conjugated linoleic acid isomers ($C_{18:2-9c,11t}$ and $C_{18:2-10t,12c}$) in fatty acids obtained from safflower oil (Ma et al., 1999). UIC were employed in the purification of gamma-linolenic acid ($C_{18:3-6c,9c,12c}$) from borage oil fatty acids (Shimada et al., 1998) and blackcurrant seed oil fatty acids (Traitlet et al., 1988). Urea fractionation was applied in the enrichment of eicosapentaenoic acid ($C_{20:5-5c,8c,11c,14c,17c}$) and docosahexaenoic acid ($C_{22:6-4c,7c,10c,13c,16c,19c}$) obtained from marine oils (Lee, 2003; Bretton, 2003). Finally, UIC were utilized in isolation and purification of stearidonic acid ($C_{18:4-d6,9,12,15}$) from fatty acids derived from blackcurrant and marine oils (Lagarde et al., 1992). Many of the experimental techniques outlined in these studies employed methanol or ethanol, anhydrous or with the presence of 5-10 vol% water, as solvents because they could be easily removed by evaporation. Some processes coupled urea fractionation with other steps such as vacuum distillation, solvent fractionation and preparative high performance liquid chromatography to isolate and purify the compounds of interest.

5.4.3 Fatty acid alkyl esters (biodiesel)

Processing of fatty derivatives is frequently made easier by first converting fatty acids into their corresponding esters. Consequently, urea fractionation was applied to alkyl ester mixtures employing methanol or ethanol, anhydrous or aqueous (5-15 vol%), as polar solvents. UIC were employed to isolate and purify malvalic (*cis*-9,10-methyleneheptadec-8-enoic) and sterculic (*cis*-9,10-methyleneoctadec-9-enoic) acid methyl esters from crude FAME mixtures derived from *Bombax munguba* and *Sterculia foetida* seed oils (Fehling et al., 1998). A continuous UIC-based process was developed to isolate gamma-linoleic acid esters from linseed and marine oil fatty acid ethyl esters (Traitlet & Wille, 1992). For that process, solid crystals were precipitated by cooling heterogeneous solutions to below room temperature in a series of scraped-surface heat exchangers. Another process coupled urea fractionation with vacuum distillation to isolate eicosapentaenoic acid ethyl esters from marine oil (Fujita & Makuta, 1983). A process integrating transesterification and urea fractionation step was also patented (Bertioli et al., 1997). After separation of the glycerol layer, product alkyl esters were mixed with urea and ethanol to perform the fractionation step. This process was designed for industrial-scale production of highly pure gamma-linoleic, eicosapentaenoic and docosahexaenoic acid esters.

There is a paucity of scientific studies directly applying urea fractionation to improve the cold flow properties of biodiesel. Nevertheless, the following general procedure was derived from studies on fatty acid mixtures (Bist & Tao, 2005; Bist et al., 2007, 2009):

1. Mix urea with FAME and methanol or ethanol
 2. Heat mixture to form a heterogeneous solution
 3. Cool the mixture to between 15-30°C
 4. Separate solids crystals from liquid by vacuum filtration, centrifugation or decantation.
- The filtrate is processed to remove alcohol by evaporation and trace urea concentrations by extraction with organic solvent and slightly acidic (pH = 3-4) water. The final product biodiesel is enriched in unsaturated FAME content and has a significantly reduced CP. Product yields are adjusted by varying urea concentration, solvent volume and cooling temperature.

Experimental conditions and results from several UIC trials on fractionation of SME are summarized in Table 6. These data show that increasing urea/SME mass ratio at constant alcohol volume decreases Σ Sats and CP of the final liquid product. These improvements come at the expense of reduced yield and monounsaturated FAME (methyl oleate)

concentration in the product. Losses caused by increasing urea/SME mass ratio may be partially recouped by crystallization of UIC at a higher cooling temperature.

A pilot-scale process directly integrating urea fractionation and transesterification for conversion of lipid feedstock into biodiesel with enhanced cold flow properties was developed (Bist et al, 2007, 2009). The urea fractionation step was designed to accept crude products from the transesterification step where biodiesel is mixed with glycerol co-product. Fractionation was demonstrated with methanol and ethanol solvents. For fractionation of SME, a 44.6 mass% yield of liquid product with $\Sigma\text{Sats} = 1.7$ mass% and CP = -34°C was recovered. Decreases in CP were non-linear with respect to increasing urea/SME mass ratio especially for ratios exceeding 0.5:1. Concentrations of all unsaturated FAME components were enriched in liquid products from fractionation with urea/SME mass ratios less than 0.5:1. In contrast, higher mass ratios decreased methyl oleate ($\text{C}_{18:1}$) concentrations in liquid products.

| Urea/SME/Alcohol (g/g/mL) | Alcohol | T_{Soln} ($^\circ\text{C}$) | T_{B} ($^\circ\text{C}$) | Yield (g/g) | ΣSats (mass%) | $\text{C}_{18:1}$ (mass%) | CP ($^\circ\text{C}$) |
|------------------------------|----------|---|--|----------------|--------------------------------|------------------------------|----------------------------|
| Non-fractionated SME | None | | | | 12.9 | 23.5 | 0 |
| 24.1/10.1/160 | Ethanol | 67 | 20 | 0.783 | 7.7 | 24.6 | -10 |
| 24.1/16.0/160 | Ethanol | 72 | 30 | 0.759 | 2.3 | 22.5 | -16 |
| Non-fractionated SME | None | | | | 15.0 | 25.9 | 3 |
| 24.0/16.8/120 | Methanol | 55 | 25 | 0.517 | 2.3 | 24.4 | -23 |
| 24.0/24.0/120 | Methanol | 55 | 20-25 | 0.429 | 0.0 | 19.2 | -57 |

Table 6. Urea fractionation of soybean oil-FAME (SME). Sources: Bist & Tao, 2005; Bist et al., 2009. T_{Soln} = temperature where heterogeneous solution formed; $\text{C}_{18:1}$ = methyl oleate; NA = not applicable.

Another study (Davis et al., 2007) more broadly investigated the effects of increasing urea/SME mass ratio on yield, ΣSats and CP of recovered liquid fractions. Results confirmed that increasing urea/SME mass ratio from 0:1 to 1:1 decreased ΣSats and CP at the expense of reduced final product yield. Furthermore, increasing urea concentration increased the mass of methyl oleate bound to the clathrates during cooling which led to lower concentrations in the liquid filtrate. It was demonstrated that 80 mass% yield of fractionated SME with CP of -9°C could be produced by applying a urea/SME mass ratio of 0.3:1. Increasing the mass ratio to 0.5:1 reduced methyl stearate (C_{18}) content in the filtrate to 0.0 mass%. Product from the liquid phase was recovered with 67 mass% yield and had CP below -15°C . Further increasing mass ratio to 1:1 produced a 44 mass% yield of fractionated SME with essentially $\Sigma\text{Sats} = 0.0$ mass% and CP below -55°C .

5.5 Other fractionation processes

Many other fractionation processes have been applied in fractionation of fatty acid alkyl esters and other fatty derivatives for a variety of purposes. Processes that may show

potential to directly improve the cold flow properties of biodiesel include vacuum distillation, adsorption, membrane separations and supercritical fluid extraction. Each of these techniques are discussed below.

5.5.1 Vacuum distillation

This technique is frequently applied in refining of fatty derivatives. Distilled fractions are collected based on differences in volatility (boiling point) of components and fractions may be isolated according to relative chain length. Application under reduced pressure and with packed-columns operating at low temperatures are generally required to maintain thermal stability of fatty acids and esters. Due to energy requirements and cost, this technique is mainly employed in production of high quality products with low impurity levels (Krishnamurthy & Kellens, 1996). Distillation may also be coupled with other fractionation steps in refining of fatty derivatives.

One recent study (Falk & Meyer-Pittroff, 2004) applied vacuum distillation in fractionation of UCOME and animal fat-FAME. Distillation was conducted at 0.05 Pa absolute pressure and temperature did not exceed 180°C. Distillate fractions had elevated concentrations of Σ Sats while unsaturated FAME concentrations were enriched in the residuum (undistilled) fraction. For UCOME and animal fat-FAME, Σ Sats decreased from 31 to 15 mass% and from 43.5 to 30 mass%, respectively.

A process was developed for fractionation of palm kernel oil-FAME to produce technical grade methyl oleate (Heck et al., 2006). The process was performed under an absolute pressure of 25 mbar (2.5 Pa) with a reflux ratio of 2:1. The input stream consisted of mainly pre-distilled C_{16} - C_{18} FAME. These FAME were then distilled at 180°C to separate C_{16} (distillate) and C_{18} (residuum) fractions. The residuum was subsequently distilled at 219.2°C to obtain a mixture of predominantly unsaturated C_{18} plus some C_{16} in the distillate. The distillate from the second step was again distilled at 219.7°C to enrich the methyl oleate ($C_{18:1}$) product. Final yield was 52.1 mass% liquid FAME composed of 80.1 mass% methyl oleate and Σ Sats = 1.58 mass%. Increasing the reflux ratio to 2.5:1 significantly increased yield to 95.8% and decreased Σ Sats to 1.48 mass%, though methyl oleate content also decreased to 64.4 mass%.

An earlier review (Dunn & Moser, 2010) examined the effects of trace concentrations of saturated monoacylglycerols and free (non-acylated) steryl glucosides on cold weather storage stability of biodiesel. High-vacuum distillation has been applied by fuel producers to remove these and other minor constituents from biodiesel during production and processing. However, other lower cost processes involving cooling and filtering the biodiesel as it leaves the production facility are also being developed.

5.5.2 Adsorption

Adsorption was applied in fractionation of triacylglycerols and other mixtures of fatty materials into high-purity components. Separation is based on specific components adsorbing either on solids suspended in solution or on the surface of a stationary phase. Recovery of adsorbed components is made by isolating the solid phase and extracting (desorbing) them with liquid solvent. This technology is known to reduce saturates in triacylglycerols (Krishnamurthy & Kellens, 1996).

Saturated fatty acids were removed from a fatty acid mixture by passing a 10 vol% solution in acetone solvent through a solid bed molecular sieve composed of amorphous crystalline

silica (Cleary et al., 1985). The sieves were packed in a separation column and flooded with acetone at 120°C with sufficient pressure applied to maintain the liquid phase. The feed mixture was injected in pulses into the column and separated fractions were collected as withdrawn at the bottom of the column. Processes for separating polyunsaturated fatty acids based on preparative high performance liquid chromatography columns packed with Ag-silica or Ag-alumina stationary phases were also developed. These processes were coupled with urea fractionation to purify eicosapentaenoic (C_{20:5}) and stearidonic (C_{18:4}) acids from marine or blackcurrant oils (Lagarde et al., 1992; Lee, 2003).

Applications for biodiesel were developed to reduce concentrations of monoacylglycerols, steryl glucosides and other minor constituents and for cleaning trace contaminants from transesterification product streams. Selective adsorption was applied in fractionation of a mixture of saturated and unsaturated FAME employing X- and Y-type zeolites embedded with sodium and potassium exchange cations (Neuzil & Derosset, 1977). Selectivity for adsorption increased with increasing degree of unsaturation allowing separation of methyl oleate and linoleate from a feed mixture that also contained methyl palmitate and stearate in a 25 vol% blend with *n*-heptane. Separation was carried out at 125°C and under 50 psig (345 kPa) pressure and bound unsaturated FAME were recovered by desorption with *p*-diethylbenzene. The best results were observed for columns packed with 20-24 U.S. mesh particle size X-type zeolites embedded with potassium cations.

More recently, SME was fractionated to enrich polyunsaturated FAME concentration by passing a mixture diluted in hexane solvent at room temperature through a gravity filtered column packed with silver nitrate (AgNO₃)-impregnated silica (SiO₂) gel (Ghebreyessus et al., 2006). Separations were performed at room temperature and a very high 100:1 (vol) dilution ratio in hexane. The SME/hexane mixture was gravity filtered down the vertical column packed with adsorbent. Selectivity increased with increasing degree of unsaturation and polyunsaturated components were desorbed with diethyl ether. From the perspective of isolating FAME enriched in unsaturated components, a column packed with 1:9 g/g AgNO₃/SiO₂ adsorbent yielded 45 vol% liquid with Σ Sats = 2.1 mass%. Although increasing AgNO₃/SiO₂ mass ratio increased the yield and decreased Σ Sats, this improvement was accompanied by a disproportionate decrease in monounsaturated FAME (C_{18:1}) content.

5.5.3 Membrane separations

This technology was also developed for extraction and separation of components from fatty derivatives. Flat porous nitrocellulose membranes may selectively transfer long chain free fatty acids from mixtures with triacylglycerols into an aqueous phase (Kocherginsky & Grishchenko, 2000). Oil phases with higher viscosities demonstrated slower transfer (diffusion) rates. Non-porous cellulose acetate membranes were studied in fractionation of free fatty acids and monoacylglycerols, diacylglycerols and triacylglycerols formed by hydrolysis of high-oleic sunflowerseed oil (Koike et al., 2002). Stirred cells were operated at 40°C and 6 MPa pressure and the hydrolysate mixture was diluted in ethanol. Results showed the rates of retention in descending order were triacylglycerol > diacylglycerol > monoacylglycerol > fatty acids suggesting this technique may be useful in cleaning transesterification product streams or reducing effects of monoacylglycerol on cold weather storage stability of biodiesel.

Low-pressure dialysis was applied in the partial separation of UCOME into saturated and unsaturated FAME-rich fractions (Wichmann et al., 2008). The experimental apparatus consisted of a pocket shaped from the dialysis membrane holding within it the UCOME and

surrounded on the outside by *n*-hexane. Permeation of unsaturated FAME components was hindered due to the bend in the tailgroup about the double bond(s) in contrast to the straight-chained tailgroup of saturated FAME. Although a polyisoprene-based rubber membrane (MWCO < 3200 daltons) had a larger permeation rate, a polyethylene membrane (MWCO < 530 daltons) was more chemically resistant. Both membranes performed well with respect to diffusion of saturated FAME into the dialysate (permeate).

5.5.4 Supercritical fluid extraction

This process is more expensive than other fractionation techniques and considered to be a scientific curiosity. It's practical use is generally limited to extraction of high-value components such as eicosapentaenoic and docosahexaenoic acids from marine and other oils (Illingworth, 2002). Fractionation is based on solubility (that is, density) of components in the supercritical fluid. Applications have been developed to fractionate milk fat into short-, medium- and long-chain triacylglycerols, remove cholesterol from animal fats, prepare cold spreadable butters, separation of monoacylglycerols and diacylglycerols from triacylglycerols and fractionation of fatty acids and esters derived from vegetable oils and fats. The process generally requires high pressure and a high degree of technical complexity which hinder it's application on a large-scale (Krishnamurthy & Kellens, 1996).

Supercritical fluid extraction is frequently applied to fractionate fatty acid alkyl esters of vegetable and marine oils to enrich polyunsaturated fatty acid components. Carbon dioxide (CO₂) has a relatively mild critical temperature (31.1°C) making it an attractive choice for processing of fatty derivatives (Nilsson et al., 1988). Partition coefficients of alkyl esters between CO₂ and liquid phase decrease with increasing chain length due to an increase in density. Partition coefficients may be increased by decreasing temperature or increasing pressure. Separation based on degree of unsaturation is less selective than variation in chain length (Nilsson, 1996).

This technique was demonstrated to isolate and purify ethyl esters of eicosapentaenoic and docosahexaenoic acid derived from menhaden oil after preparative concentration by urea fractionation (Nilsson et al., 1988, 1989). Another study (Perretti et al., 2007) reported a reduction in Σ Sats (C₁₆-C₂₀) in marine oil ethyl esters from 10.1 to 1.8 mass% after extraction by supercritical CO₂ in a column packed with stainless steel rings and operated at 40°C and 150 bar (15 MPa). Increasing pressure or CO₂ flowrate increased partition coefficient for extracted saturated ethyl esters.

Based on a review of available scientific literature, very little activity has been devoted to the direct application of supercritical fluid extraction to improve the cold flow properties of biodiesel. However, it may be inferred from studies with fatty acid ethyl esters that this technique will be useful in reducing the content of smaller chain length saturated FAME. Thus, supercritical CO₂ extraction may be productively applied to biodiesel since many feedstocks for biodiesel typically have saturated fatty acid components that are predominantly palmitic as opposed to stearic and larger acids.

6. Effects of fraction on other fuel properties

Many fuel properties are directly related to the fatty acid composition of biodiesel. Reducing Σ Sats through fractionation may affect properties besides cold flow properties. An earlier study (Dunn, 1998) examined the effects of dry and solvent fractionation on the fuel properties of SME. With respect to kinematic viscosity at 40°C and acid value,

fractionated SME remained within specifications outlined in ASTM standard D 6751 for biodiesel. Although specific gravity increased slightly after dry fractionation, it was not affected by solvent fractionation. Peroxide value increased slightly after dry and solvent fractionation. As expected, enriching the total concentration of unsaturated FAME in SME increased the iodine value. Liquid fractions exhibiting larger reductions in CP and other cold flow properties demonstrated larger increases in iodine value, though iodine values remained within range of values for non-fractionated SME.

Dry and solvent fractionation of SME significantly decreased oxidative stability as determined by the oil stability index (OSI) measured isothermally at 50°C (Dunn, 1998). In this case, reduction in Σ Sats caused concentrations of unsaturated and polyunsaturated FAME to increase in the final liquid fraction making it more susceptible to oxidation from contact with air. Another study (Sahlabji et al., 2007) showed that dry fractionation of animal fat-FAME led to increased concentrations of oxidation inhibitors (antioxidants) α -tocopherol and butylated hydroxytoluene (BHT). It was suggested that these antioxidants were sterically hindered from aligning along the surface of solid crystal nuclei as they form causing them to remain in the bulk liquid phase during cooling. Similar results have been reported for enriched β -carotene concentrations in unsaturated fractions collected from palm olein (Illingworth, 2002).

Regardless of the enriching effects of fractionation on antioxidant concentrations in low-melting products, it is likely that the increase in total unsaturated, especially polyunsaturated alkyl ester content, causes a net reduction in oxidative stability with respect to non-fractionated esters. For example, distillate fractions from vacuum distillation of animal fat-FAME generally had higher OSI (at 110°C) than the undistilled FAME because these fractions had higher Σ Sats (Falk & Meyer-Pittroff, 2004). Despite an increase in total antioxidant concentration, the non-distilled (residuum) fraction had OSI < 1 h compared to a value of 1.3 h for the undistilled FAME. This result suggested that enriching the unsaturated and polyunsaturated FAME contents in the residuum fraction had a stronger influence on oxidative stability than enrichment of antioxidant concentration. Similar results were observed for residuum fractions obtained from vacuum distillation of UCOME. Ignition quality of diesel fuels is related to ignition delay time, which is correlated to the cetane number of the fuel. Cetane number may be adversely affected by fractionation of biodiesel. Increasing the degree of unsaturation in a hydrocarbon structure decreases cetane number with respect to constant chain length (Harrington, 1986; Knothe et al., 1996, 1997). Decreasing cetane number generally increases ignition delay time, an effect that may worsen engine performance and emissions.

Technologies such as solvent, UIC, adsorption and membrane fractionation may employ organic solvents and other reagents that have special requirements for safe storage and handling. After fractionation is complete the solvents and reagents need to be separated and removed to collect the desired liquid products. Some organic solvents may need to be recycled to reduce costs. Distillation and supercritical fluid extraction processes will require special equipment for handling fluids at very low or very high pressures.

Fractionation itself may impact biodiesel production economics. Separating and removing high-MP components increases cost per unit mass. Secondary effects may be assumed if special conditions and equipment are required to maintain fuel quality of fractionated biodiesel during storage and handling. Another consideration is the disposition of byproduct fractions with enriched Σ Sats. Derivatives from these byproducts might be utilized in formulation of lubricants, surfactants, detergents, plasticizers, pharmaceuticals,

water-proofing agents and cosmetics as well as fuel additives for heavy-grade petrodiesel or residual fuels.

7. Conclusions

Cold flow properties and performance continue to influence the development of biodiesel as an alternative diesel fuel or extender. On-road transportation, power generation, heaters and boilers, locomotives, farm vehicles and aviation applications may provide incentives for development of commercial-scale processes to improve cold flow properties of biodiesel.

The fatty acid composition of biodiesel is the main factor in determining their CP, PP, CFPP and LTFT. Development of feedstocks with inherently higher Σ Sats, such as animal fats or used cooking oils, will direct research efforts in development of processing technologies to improve their cold flow properties. In some cases, the influences of Σ Sats composition may be linearly correlated to CP or CFPP. However, the cold flow properties of biodiesel from various feedstocks can be calculated from thermodynamic models based on freezing point theory provided the crystallization properties of each individual component in an alkyl ester mixture are known.

Previous research demonstrated that the most promising approaches for improving the cold flow properties of biodiesel are those that reduce CP. This conclusion was subsequently extended to biodiesel/petrodiesel blends with at least 10 vol% biodiesel (blend ratio = B10). Several studies have examined a number of process technologies for improving the cold flow properties of biodiesel. Among these, fractionation demonstrated great potential for effectively reducing CP of biodiesel.

Fractionation improves cold flow properties of biodiesel by modifying its fatty acid profile to remove high-melting components resulting in reduced crystallization onset temperatures. For biodiesel such as SME or TME, this generally means separating and removing saturated FAME which are mainly methyl palmitate (MP = 28.5°C) and stearate (MP = 37.7°C) enriching the concentration of methyl oleate, linoleate and linolenate (MP < -20.2°C). Dry fractionation, with and without crystallization modifiers, solvent fractionation and urea fractionation may significantly reduce CP. In some cases, yields exceeded 80-90 mass% liquid fractions based on the starting material. Other fractionation technologies evaluated were vacuum distillation, adsorption, membrane separations and supercritical fluid extraction. Urea clathrates, vacuum distillation and adsorption were also applied in the removal of trace concentrations of saturated monoacylglycerols and steryl glucosides, minor constituents that may be problematic to the cold weather storage stability of biodiesel and biodiesel/petrodiesel blends.

Other adaptations to the fractionation technology may be explored in future studies for application to biodiesel. An example is surfactant fractionation. Applied mostly to fats and vegetable oils, this process is similar to dry fractionation where after the crystallization the separation of solid crystals is assisted by adding a cool aqueous solution of surfactant (sodium dodecyl sulfate) containing an electrolyte (magnesium or aluminum sulfate). The combination of surfactant wetting agent and electrolyte allows solid crystals to be suspended in the aqueous phase. After separation of oil and aqueous phases by centrifugation, fractions are heated, washed and dried to remove additives. Surfactant fractionation is more efficient than dry fractionation with respect to separation efficiency and yield of liquid fractions. Its main disadvantages are high operating costs and decontamination of end products (Illingworth, 2002; Kellens & Hendrix, 2000; Krishnamurthy & Kellens, 1996; O'Brien, 1998).

Another example may be to inject a low-boiling point coolant such as ammonia, CO₂ or halogenated hydrocarbon into the alkyl ester mixture. It was shown that applying this approach to fatty acid mixtures with or without solvent improved separation efficiency of solid and liquid phases (Zondek, 1978). The injection of rapidly evaporating coolant promoted formation of a slurry with crystals sufficiently large to facilitate separation by filtration.

Most studies on supercritical fluid extraction of unsaturated fatty acids and esters have been performed with supercritical CO₂. However, attention might be put into supercritical ethylene or propane as biodiesel and other derivatives demonstrate much higher solubilities in these solvents (Illingworth, 2002). Liquid-based extraction may also be explored for application to biodiesel. For example, dodecanoic and myristic acid were separated by crystallizing the mixture in aqueous ethanol and collecting solid crystals on a Nylon monofilament filter (Maeda et al., 1999).

8. Abbreviations

| | |
|-------|--|
| CFPP | Cold filter plugging point |
| CP | Cloud point |
| FAME | Fatty acid methyl esters |
| LTFT | Low-temperature flow test |
| MP | Melting point |
| PP | Pour point |
| ΣSats | Total concentration of saturated fatty acid alkyl esters |
| SME | Soybean oil-FAME; methyl soyate |
| TME | Tallow-FAME; methyl tallowate |
| UCOME | Used cooking oil-FAME |
| UIC | Urea inclusion compounds |
| ULSD | Ultra-low sulfur petrodiesel fuel |

Symbols

| | |
|------------------|--|
| $C_{M[:N]}$ | Chain length of fatty acid group (R-COO); M = number of carbon atoms, N = total number of double bonds |
| C_p | Heat capacity |
| ΔH_{fus} | Enthalpy of fusion (or melting) |
| R^2 | Adjusted correlation coefficient |
| R_g | Gas constant |
| T_f | Crystallization onset temperature of a component in a mixture |
| x_i | Mole fraction of component 'i' |
| γ_i | Activity coefficient of component 'i' |
| σ_y | Standard error of the y-estimate |

9. References

- Abu-Nasr, A. M.; Potts, W. M. & Holman, R. T. (1954). Highly unsaturated fatty acids. II. Fractionation by urea inclusion compounds. *J. Am. Oil Chem. Soc.*, 31, 16-20, ISSN 0003-021X

- Anderson, D. (1996). A primer on oils processing technology, In: *Bailey's Industrial Oil and Fat Products 5th Edition, Vol. 4. Edible Oil and Fat Products*, Hui, Y. H. (Ed.), pp. 31-45, Wiley-Interscience, ISBN 0-471-59428-8, New York
- ASTM (2008a). Standard specification for diesel fuel oils, In: *Annual Book of ASTM Standards Vol. 05.01*, method D 975, ASTM International, West Conshohocken (PA)
- ASTM (2008b). Specification for biodiesel fuel (B100) blend stock for distillate fuels, In: *Annual Book of ASTM Standards Vol. 05.04*, method D 6751, ASTM International, West Conshohocken (PA)
- Bailey, A. E. (1950). Practical melting and solidification processes, In: *Melting and Solidification of Fats*; pp. 328-346, Interscience, New York
- Bengen, F. & Schlenk Jr., W. (1949). Über neuartige additionsverbindungen des harnstoffs, *Experientia*, 5, 200, ISSN 0014-4754
- Bertioli, C.; Fumeaux, R., Ferreira, M.-C. P. & Wang, J. (1997). Concentrate of polyunsaturated fatty acid ethyl esters and preparation thereof. *U. S. Patent No. 5,679,809* (Oct. 21)
- Bist, S. & Tao, B. Y. (2005). Method for separating saturated and unsaturated fatty acid esters and use of separated fatty acid esters. *U. S. Patent Appl. 20050232956* (Oct. 20)
- Bist, S.; Tao, B. Y. & Mohtar, S. (2007). Method for preparation, use and separation of fatty acid esters. *U. S. Patent Appl. 20070251141* (Nov. 1)
- Bist, S.; Tao, B. Y. & Mohtar, S. (2009). Method for separating saturated and unsaturated fatty acid esters and use of separated fatty acid esters. *U. S. Patent Appl. 20090199462* (Aug. 13)
- Botros, M. G. (1997). Enhancing the cold flow behavior of diesel fuels. *SAE Technical Paper Series*, Paper No. 972899, ISSN 0148-7191
- Bretton, G. (2003). Enzymatic methods for polyunsaturated fatty acid enrichment. *U.S. Patent No. 6,537,787* (Mar. 25)
- Brown, J. B. & Kolb, D. K. (1955). Applications of low temperature crystallization in the separation of the fatty acids and their compounds. *Prog. Chem. Fats Other Lipids*, 3, 58-80, ISSN 0079-6832
- Brown, G. I.; Lehmann, E. W. & Lewtas, L. (1989). Evolution of diesel fuel cold flow: The next frontier. *SAE Technical Paper Series*, Paper No. 890031, ISSN 0148-7191
- Brown, G. I.; Tack, R. D. & Chandler, J. E. (1988). An additive solution to the problem of wax settling in diesel fuels. *SAE Technical Paper Series*, Paper No. 881652, ISSN 0148-7191
- CEN (2003). *Method EN 14214: Automotive Fuels - Fatty Acid Methyl Esters (FAME) for Diesel Engines - Requirements and Test Methods*, European Committee for Standardization (CEN), Brussels
- Chandler, J. E.; Hornbeck, F. G. & Brown, G. I. (1992). The effect of cold flow additives on low temperature operability of diesel fuels. *SAE Technical Paper Series*, Paper No. 922186, ISSN 0148-7191
- Chiou, B.-S.; El-Mashad, H. M., Avena-Bustillos, R. J., Dunn, R. O., Bechtel, P. J., McHugh, T. H., Imam, S. H., Glenn, G. M., Ortiz, W. J. & Zhang, R. (2008). Biodiesel from waste salmon oil. *Trans. ASABE*, 51, 797-802, ISSN 0001-2351
- Cleary, M. T.; Kulprathipanja, S. & Neuzil, R. W. (1985). Process for separating fats. *U.S. Patent No. 4,524,029* (Jun. 18)

- Cold Flow Blending Consortium. (2005). *Evaluation of Temperature Effects for Blending Biodiesel at 2% with #1 Kerosene and #2 Diesel (National Cold Weather Blending Study)*, pp. 5-6, National Biodiesel Board, Jefferson City (MO)
- Davis, R.; Mohtar, S. & Tao, B. (2007). Production of low-temp biodiesel through urea clathration, *Proceedings of the 2007 ASABE Annual International Meeting*, Paper No. 076235, Minneapolis, June 2007, American Society of Agricultural and Biological Engineers, St. Joseph (MI)
- Delafontaine M. J.; Krishna, C. R., Dunn, R. O. & Hubert, M. (2005). Fractional crystallization of fatty acid methyl esters, In: *Final Report for NYSERDA Project PON 737, Agreement No. 8208*, New York State Energy Research and Development Authority, Albany
- Domart, C.; Miyauchi, D. T. & Sumerwell, W. N. (1955). The fractionation of marine-oil fatty acids with urea. *J. Am. Oil Chem. Soc.*, 32, 481-483, ISSN 0003-021X
- Dunn, R. O. (1998). Effect of winterization on fuel properties of methyl soyate, *Proceedings of the Commercialization of Biodiesel: Producing a Quality Fuel*, pp. 164-186, Boise (ID), July 1997, Peterson, C. L. (Ed.), University of Idaho, Moscow (ID) pp. 164-186
- Dunn, R. O. (2008). Crystallization behavior of fatty acid methyl esters. *J. Am. Oil Chem. Soc.*, 85, 961-972, ISSN 0003-021X
- Dunn, R. O. (2009). Cold-flow properties of soybean oil fatty acid monoalkyl ester admixtures. *Energy Fuels*, 23, 4082-4091, ISSN 0887-0624
- Dunn, R. O. (2010). Cold flow properties of biodiesel by automatic and manual analysis methods. *J. ASTM International*, 7, 1-15, ISSN 1546-962X
- Dunn, R. O. & Bagby, M. O. (1995). Low-temperature properties of triglyceride-based diesel fuels: Transesterified methyl esters and petroleum middle distillate/ester blends. *J. Am. Oil Chem. Soc.*, 72, 895-904, ISSN 0003-021X
- Dunn, R. O. & Bagby, M. O. (1996). Low-temperature filterability properties of alternative diesel fuels from vegetable oils, *Proceedings of the Third Liquid Fuel Conference: Liquid Fuel and Industrial Products from Renewable Resources*, pp. 95-103, ISBN 0-929355-79-2, Nashville (TN), September 1996, Cundiff, J. S., Gavett, E. E., Hansen, C., Peterson, C., Sanderson, M. A., Shapouri, H. & VanDyne, D. L. (Eds.), American Society of Agricultural Engineers, St. Joseph (MI)
- Dunn, R. O. & Moser, B. R. (2010). Cold weather properties and performance of biodiesel, In: *The Biodiesel Handbook, 2nd Edition*, Knothe, G., Krahl, J. & Van Gerpen, J. (Eds.), pp. 147-203, AOCS Press, ISBN 978-1-893997-62-2, Urbana (IL)
- Dunn, R. O.; Shockley, M. W. & Bagby, M. O. (1996). Improving the low-temperature flow properties of alternative diesel fuels: Vegetable oil-derived methyl esters. *J. Am. Oil Chem. Soc.*, 73, 1719-1728, ISSN 0003-021X
- Dunn, R. O.; Shockley, M. W. & Bagby, M. O. (1997). Winterized methyl esters from soybean oil: An alternative diesel fuel with improved low-temperature flow properties. *SAE Trans., Sec. 4: J. Fuels Lubricants*, 106, 640-649, ISSN 0096-736X
- Erhan, S. Z.; Dunn, R. O., Knothe, G. & Moser, B. R. (2008). Fuel properties and performance of biodiesel, In: *Biocatalysis and Bioenergy*, Hou, C. T. & Shaw, J.-F. (Eds.), pp. 3-57, John Wiley & Sons, Inc., Hoboken (NJ)
- Falk, O. & Meyer-Pittroff, R. (2004). The effect of fatty acid composition on biodiesel oxidative stability. *Eur. J. Lipid Sci. Technol.*, 106, 837-843, ISSN 1438-7697

- Fehling, E.; Schönwiese, S., Klein, E., Mukherjee, K. D. & Weber, N. (1998). Preparation of malvalic and sterculic acid methyl esters from *Bombax munguba* and *Sterculia foetida* seed oils. *J. Am. Oil Chem. Soc.*, 75, 1757-1760, ISSN 0003-021X
- Foglia, T. A.; Nelson, L.A., Dunn, R. O. Dunn & Marmer, W. N. (1997). Low-temperature properties of alkyl esters of tallow and grease. *J. Am. Oil Chem. Soc.*, 74, 951-955, ISSN 0003-021X
- Fujita, T. & Makuta, M. (1983). Method of purifying eicosapentaenoic acid and its esters. *U. S. Patent No. 4,377,526* (Mar. 22).
- Ghebreyessus, K. Y.; Schiltz, H. & Angelici, R. J. (2006). Partial separation of polyunsaturated fatty acid esters from FAMES by adsorption on silver nitrate-impregnated silica gel. *J. Am. Oil Chem. Soc.*, 83, 645-652, ISSN 0003-021X
- González Gómez, M. E.; Howard-Hildige, R., Leahy, J. J. & Rice, B. (2002). Winterization of waste cooking oil methyl ester to improve cold flow temperature fuel properties. *Fuel*, 81, 33-39, ISSN 0016-2361
- Graboski, M. S. & McCormick, R. L.. (1998). Combustion of fat and vegetable oil derived fuels in diesel engines. *Prog. Energy Combust. Sci.*, 24, 124-164, ISSN 0360-1285
- Gunstone, F. D. (1967). *An Introduction to the Chemistry and Biochemistry of Fatty Acids and Their Glycerides, 2nd Edition*, pp. 69-74, Chapman & Hall, London
- Hanna, M. A.; Ali, Y., Cuppett, S. L. & Zheng, D. (1996). Crystallization characteristics of methyl tallowate and its blends with ethanol and diesel fuel. *J. Am. Oil Chem. Soc.*, 73, 759-763, ISSN 0003-021X
- Harrington, K. J. (1986). Chemical and physical properties of vegetable oil esters and their effect on diesel fuel performance. *Biomass*, 9, 1-17
- Hayes, D. G. (2002). Urea inclusion compound formation. *Inform*, 13, 781-783, ISSN 0897-8026
- Hayes, D. G. (2006). Effect of temperature programming on the performance of urea inclusion compound-based free fatty acid fractionation. *J. Am. Oil Chem. Soc.*, 83, 253-259, ISSN 0003-021X
- Hayes, D. G.; Bengtsson, Y. C., Van Alstine, J. M. & Setterwall, F. (1998). Urea complexation for the rapid, ecologically responsible fractionation of fatty acids from seed oil. *J. Am. Oil Chem. Soc.*, 75, 1403-1409, ISSN 0003-021X
- Hayes, D. G.; Van Alstine, J. M. & Setterwall, F. (2000). Urea-based fractionation of seed oil samples containing fatty acids and acylglycerols of polyunsaturated and hydroxy fatty acids. *J. Am. Oil Chem. Soc.*, 77, 207-213, ISSN 0003-021X
- Heck, S.; Winterhoff, V., Gutsche, B., Fieg, G., Mueller, U., Rigal, J. & Kapala, T. (2006). Method for producing technical oleic acid methyl esters. *U.S. Patent No. 7,064,223* (Jun. 20)
- Hilber, T.; Edgar, A. H. N., Mittelbach, M. & Schmidt, E. (2006). Animal fats perform well in biodiesel. *Render* (Feb. 2006, 16-18
- Holder, G. A. & Winkler, J. (1965). Wax crystallization from diesel fuels. Part I: Cloud and pour phenomena exhibited by solutions of binary n-paraffin molecules *J. Inst. Pet.*, 51, 228-252
- Illingworth, D. (2002). Fractionation of fats, In: *Physical Properties of Lipids*, Marangoni, A. G. & Narine, S. S. (Eds.), pp. 411-447, Marcel Dekker, New York
- Imahara, H.; Minami, E. & Saka, S. (2006). Thermodynamic study on cloud point of biodiesel with its fatty acid composition. *Fuel*, 85, 1666-1670, ISSN 0016-2361

- Kalligeros, S.; Zannikos, F., Stournas, S., Lois, E., Anastopoulos, G., Teas, C. & Sakellaropoulos, F. (2003). An investigation of using biodiesel/marine diesel blends on the performance of a stationary diesel engine. *Biomass Bioenergy*, 24, 141-149, ISSN 0961-9534
- Kellens, M.; Gibon, V., Hendrix, M. & De Greyt, W. (2007). Palm oil fractionation. *Eur. J. Lipid Sci. Technol.*, 109, 336-349, ISSN 1438-7697
- Kellens, M. & Hendrix, M. (2000). Fractionation, In: *Introduction to Fats and Oils Technology, 2nd Edition*, O'Brien, R. D., Farr, W. E. & Wan, P. J. (Eds.), pp. 197-207, AOCS Press, ISBN 1-893997-13-8, Champaign (IL)
- Kerschbaum, S.; Rinke, G. & Schubert, K. (2008). Winterization of biodiesel by micro process engineering. *Fuel*, 87, 2590-2597, ISSN 0016-2361
- Knothe, G.; Bagby, M. O. & Ryan III, T. W. (1996). The influence of various oxygenated compounds on the cetane numbers of fatty acids and esters, *Proceedings of the Third Liquid Fuels Conference: Liquid Fuels and Industrial Products from Renewable Resources*, Cundiff, J. S., Gavett, E. E., Hansen, C., Peterson, C., Sanderson, M. A., Shapouri, H. & VanDyne, D. L. (Eds.), pp. 54-66, ISBN 0-929355-79-2, Nashville (TN), September 1996, American Society of Agricultural Engineers, St. Joseph (MI)
- Knothe, G.; Bagby, M. O. & Ryan III, T. W. (1997). Cetane numbers of fatty compounds: Influence of compound structure and of various potential cetane improvers. *SAE Technical Paper Series*, Paper No. 971681, ISSN 0148-7191
- Knothe, G. & Dunn, R. O. (2001). Biofuels derived from fats and oils, In: *Oleochemical Manufacture and Applications*, Gunstone, F. D. & Hamilton, R. J. (Eds.), pp. 106-163, Sheffield Academic, ISBN 1-84127-219-1, Sheffield, UK
- Knothe, G. & Dunn, R. O. (2005). Biodiesel: An alternative diesel fuel from vegetable oils or animal fats, In: *Industrial Uses of Vegetable Oils*, Erhan, S. Z. (Ed.), pp. 42-89, AOCS Press, ISBN 1-893997-84-7, Champaign (IL)
- Knothe, G. & Dunn, R. O. (2009). A comprehensive evaluation of the melting points of fatty acids and esters determined by differential scanning calorimetry. *J. Am. Oil Chem. Soc.*, 86, 843-856, ISSN 0003-021X
- Knothe, G., Krahl, J. & Van Gerpen, J. (Eds.). (2010). *The Biodiesel Handbook, 2nd Edition*, p. 462, AOCS Press, ISBN 978-1-893997-62-2, Urbana (IL)
- Kocherginsky, N. M. & Grishchenko, A. B. (2000). Mass transfer of long chain fatty acids through liquid-liquid interface stabilized by porous membrane. *Sep. Purification Technol.*, 20, 197-208, ISSN 1383-5866
- Koike, S.; Subramanian, R., Nabetani, H. & Nakajima, M. (2002). Separation of oil constituents in organic solvents using polymeric membranes. *J. Am. Oil Chem. Soc.*, 79, 937-942, ISSN 0003-021X
- Krishnamurthy, R. & Kellens, M. (1996). Fractionation and crystallization, In: *Bailey's Industrial Oil and Fat Products, 5th Edition, Vol. 4, Edible Oil and Fat Products: Processing Technology*, Hui, Y. H. (Ed.), pp. 301-338, Wiley-Interscience, ISBN 0-471-59428-8, New York
- Lagarde, M.; Traitler, H. & Wille, H.-J. (1992). Isolation of stearidonic acid from fatty acid mixtures. *U. S. Patent No. 5,130,449* (Jul. 14)
- Larsson, K. & Quinn, P. J. (1994). Physical properties: Structural and physical characteristics, In: *The Lipid Handbook 2nd Edition*, Gunstone, F. D., Harwood, J. L. & Padley, F. B. (Eds.), pp. 401-430, Chapman & Hall, ISBN 0-412-43320-6, London

- Lee, I.; Johnson, L. A. & Hammond, E. G. (1996). Reducing the crystallization temperature of biodiesel by winterizing methyl soyate. *J. Am. Oil Chem. Soc.*, 73, 631-636, ISSN 0003-021X
- Lee, S. K. (2003). Method for isolating high-purified unsaturated fatty acids using crystallization. *U. S. Patent No. 6,664,405* (Dec. 13)
- Lewtas, K.; Tack, R. D., Beiny, D. H. M. & Mullin, J. W. (1991). Wax crystallization in diesel fuel: Habit modification and the growth of *n*-alkane crystals, In: *Advances in Industrial Crystallization*, Garside, J., Davey, R. J. & Jones, A. G. (Eds.), pp. 166-179, Butterworth-Heinemann, Oxford (UK)
- Ma, D. W. L.; Wierzbicki, A. A., Field, C. J. & Clandinin, M. T. (1999). Preparation of conjugated linoleic acid from safflower oil. *J. Am. Oil Chem. Soc.*, 76, 729-730, ISSN 0003-021X
- Maeda, K.; Nomura, Y., Tai, K., Ueno, Y., Fukui, K. & Hirota, S. (1999). New crystallization of fatty acids from aqueous ethanol solution with liquid-liquid extraction. *Ind. Eng. Chem. Res.*, 38, 2428-2433, ISSN 0888-5885
- McMillan, M. L. & Barry, E. G. (1983). Fuel and vehicle effects on low-temperature operation of diesel vehicles: The 1981 CRC field test. *SAE Technical Paper Series*, Paper No. 830594, ISSN 0148-7191
- Moser, B. R. (2008). Influence of blending canola, palm, soybean, and sunflower oil methyl esters on fuel properties of biodiesel. *Energy Fuels*, 22, 4301-4306, ISSN 0887-0624
- Neuzil, R. W. & Derosset, A. J. (1977). Process for separating esters of fatty acids by selective adsorption. *U. S. Patent No. 4,049,688* (Sep. 20)
- Newey, H. A.; Shokal, E. C., Mueller, A. C., Bradley, T. F. & Fetterly, L. C. (1950). Segregation of fatty acids and their derivatives by extractive crystallization with urea. *Ind. Eng. Chem.*, 42, 2538-2541, ISSN 1226-086X
- Nilsson, W. B. (1996). Supercritical fluid extraction and fractionation of fish oils, In: *Supercritical Fluid Technology in Oil and Lipid Chemistry*, King, J. W. & List, G. R. (Eds.), pp. 180-212, AOCS Press, ISBN 0-935315-71-3, Champaign (IL)
- Nilsson, W. B.; Gauglitz, Jr., E. J., Hudson, J. K., Stout, V. F. & Spinelli, J. (1988). Fractionation of menhaden oil ethyl esters using supercritical fluid CO₂. *J. Am. Oil Chem. Soc.*, 65, 109-117, ISSN 0003-021X
- Nilsson, W. B.; Gauglitz, Jr., E. J. & Hudson, J. K. (1989). Supercritical fluid fractionation of fish oil esters using incremental pressure programming and a temperature gradient. *J. Am. Oil Chem. Soc.*, 66, 1596-1600, ISSN 0003-021X
- O'Brien, R. D. (1998). *Fats and Oils: Formulating and Processing for Applications*, pp. 109-121, Technomic, London
- Owen, K. & Coley, T. (1990). Diesel fuel low-temperature characteristics, In: *Automotive Fuels Handbook*, pp. 353-403, Society of Automotive Engineers, ISBN 1-56091-064-X, Warrendale (PA)
- Park, J.-Y.; Kim, D.-K., Lee, J.-P., Park, S.-C., Kim, Y.-J. & Lee, J.-S. (2008). Blending effects of biodiesels on oxidation stability and low temperature flow properties. *Bioresource Technol.*, 99, 1196-1203, ISSN 0960-8524
- Peretti, G.; Motori, A., Bravi, E., Favati, F., Montanari, L. & Fantozzi, P. (2007). Supercritical carbon dioxide fractionation of fish oil fatty acid ethyl esters. *J. Supercritical Fluids*, 40, 349-353, ISSN 0896-8446

- Peterson, C. L.; Taberski, J. S., Thompson, J. C. & Chase, C. L. (2000). The effect of biodiesel feedstock on regulated emissions in chassis dynamometer tests of a pickup truck. *Trans. ASAE*, 43, 1371-1381, ISSN 0001-2351
- Rajah, K. K. (1996). Fractionation of fat, In: *Separation Processes in the Food and Biotechnology Industries: Principles and Applications*, Grandison, A. S., & Lewis, M. J. (Eds.), pp. 207-242, Technomic, Lancaster
- Rashid, U. & Anwar, F. (2008). Production of biodiesel through optimized alkaline-catalyzed transesterification of rapeseed oil. *Fuel*, 87:265-73, ISSN 0016-2361
- Sahlabji, T.; Wichmann, H., Dieckmann, H., Jopke, P. & Bahadir, M. (2007). Chemical aspects of fractional crystallization of fatty acid methyl esters produced from waste fats. *CLEAN - Soil Air Water*, 35, 323-328, ISSN 1863-0650
- Sarin, R.; Sharma, M., Sinharay, S. & Malhotra, R. K. (2007). Jatropha-palm biodiesel blends: An optimum mix for Asia. *Fuel*, 86, 1365-1371, ISSN 0016-2361
- Schlenk, H. Urea inclusion compounds of fatty acids. (1954.) *Prog. Chem. Fats Other Lipids*, 2, 243-267, ISSN 0079-6832
- Schlenk, H. & Holman, R. T. (1950). Separation and stabilization of fatty acids by urea complexes. *J. Am. Chem. Soc.*, 72, 5001-5004, ISSN 0002-7863
- Serdari A.; Fragioudakis, K., Kalligeros, S., Stournas, S. & Lois, E. (2000). Impact of using biodiesels of different origin and additives on performance of a stationary diesel engine. *J. Eng. Gas Turbines Power (Trans. ASME)*, 122, 624-631, ISSN 0742-4795
- Shimada, U.; Sakai, N., Sugihara, A., Fujita, H., Honda, Y. & Tominaga, Y. (1998). Large-scale purification of γ -linolenic acid by selective esterification using *Rhizopus delemar* lipase. *J. Am. Oil Chem. Soc.*, 75, 1539-1543, ISSN 0003-021X
- Suppes, G. J.; Fox, T. J., Gerdes, K. R., Jin, H., Burkhart, M. L. & Koert, D. N. (2000). Cold flow and ignition properties of Fischer-Tropsch fuels. *SAE Technical Paper Series*, Paper No. 2000-01-2014, ISSN 0148-7191
- Swern, D. (1955). Urea and thiourea complexes in separating organic compounds. *Ind. Eng. Chem.*, 47, 216-221, ISSN 1226-086X
- Swern, D. & Parker, W. E. (1952a). Application of urea complexes in the purification of fatty acids, esters, and alcohols. I. Oleic acid from inedible animal fats. *J. Am. Oil Chem. Soc.*, 29, 431-434, ISSN 0003-021X
- Swern, D. & Parker, W. E. (1952b). Application of urea complexes in the purification of fatty acids, esters, and alcohols. II. Oleic acid and methyl oleate from olive oil. *J. Am. Oil Chem. Soc.*, 29, 614-615, ISSN 0003-021X
- Swern, D. & Parker, W. E. (1953). Application of urea complexes in the purification of fatty acids, esters, and alcohols. III. Concentrates of natural linoleic and linolenic acids. *J. Am. Oil Chem. Soc.*, 30, 5-7, ISSN 0003-021X
- Tang, H.; De Guzman, R. C., Salley, S. O. & Ng, K. Y. S. (2008). Formation of insolubles in palm oil-, yellow grease-, and soybean oil-based biodiesel blends after cold soaking at 4°C. *J. Am. Oil Chem. Soc.*, 85, 1173-1182, ISSN 0003-021X
- Toro-Vazquez, J. F.; Briceño-Montelongo, M., Dibildox-Alvarado, E., Charó-Alonso, M. & Reyes-Hernández, J. (2000). Crystallization kinetics of palm stearin in blends with sesame seed oil. *J. Am. Oil Chem. Soc.*, 77, 297-310, ISSN 0003-021X
- Traitler, H. & Wille, H.-J. (1992). Process for the continuous fractionation of a mixture of fatty acids. *U. S. Patent No. 5,106,542* (Apr. 21)

- Traitler, H.; Wille, H. J. & Studer, A. (1988). Fractionation of blackcurrant seed oil. *J. Am. Oil Chem. Soc.*, 65, 755-760, ISSN 0003-021X
- Westbrook, S. R. (2003). Fuels for land and marine diesel engines and for non-aviation gas turbines, In: *Significance of Tests for Petroleum Products, 7th Edition*; Rand, S. J. (Ed.), pp. 63-81, ASTM International, ISBN 0-8031-2097-4, West Conshohocken (PA)
- Westbrook, S. R. & LeCren, R. (2003). Automotive diesel and non-aviation gas turbine fuels, In: *Fuels and Lubricants Handbook: Technology, Properties, Performance and Testing*, Totten, G. E., Westbrook, S. R. & Shah, R. J. (Eds.), pp. 115-144, ASTM International, West Conshohocken (PA)
- Wichmann, H.; Sahlabji, T., Ohnesorge, M., Vogt, R. & Bahadir, M. (2008). Feasibility study on membrane-aided cleanup and fractionation of fatty acid esters produced from waste fats. *CLEAN - Soil Air Water*, 36, 840-844, ISSN 1863-0650
- Wu, M.; Ding, H., Wang, S. & Xu, S. (2008). Optimizing conditions for the purification of linoleic acid from sunflower oil by urea complex fractionation. *J. Am. Oil Chem. Soc.*, 85, 677-684, ISSN 0003-021X
- Wyatt, V. T.; Hess, M. A., Dunn, R. O., Foglia, T. A., Haas, M. J. & Marmer, W. N. (2005). Fuel properties and nitrogen oxide emission levels of biodiesel produced from animal fats. *J. Am. Oil Chem. Soc.*, 82, 585-591, ISSN 0003-021X
- Zabarnick, S.; Widmor, N. & Vangsness, M. (2002). Studies of urea treatment on the low-temperature properties of jet fuel. *Energy Fuels*, 16, 1565-1570, ISSN 0887-0624
- Zhou, Y. & Hartel, R. W. (2006). Phase behavior of model lipid systems: Solubility of high-melting fats in low-melting fats. *J. Am. Oil Chem. Soc.*, 83, 505-511, ISSN 0003-021X
- Zondek, K. (1978). Process for separating crystallizable fractions from mixtures thereof. *U. S. Patent No. 4,129,583* (Dec. 12)

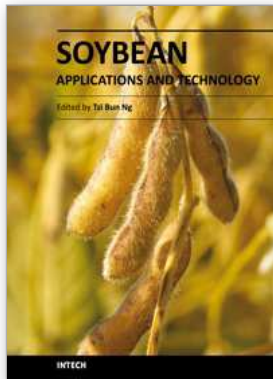

Soybean - Applications and Technology

Edited by Prof. Tzi-Bun Ng

ISBN 978-953-307-207-4

Hard cover, 402 pages

Publisher InTech

Published online 26, April, 2011

Published in print edition April, 2011

Soybean is an agricultural crop of tremendous economic importance. Soybean and food items derived from it form dietary components of numerous people, especially those living in the Orient. The health benefits of soybean have attracted the attention of nutritionists as well as common people.

How to reference

In order to correctly reference this scholarly work, feel free to copy and paste the following:

Robert O. Dunn (2011). Improving the Cold Flow Properties of Biodiesel by Fractionation, Soybean - Applications and Technology, Prof. Tzi-Bun Ng (Ed.), ISBN: 978-953-307-207-4, InTech, Available from: <http://www.intechopen.com/books/soybean-applications-and-technology/improving-the-cold-flow-properties-of-biodiesel-by-fractionation>

INTECH

open science | open minds

InTech Europe

University Campus STeP Ri
Slavka Krautzeka 83/A
51000 Rijeka, Croatia
Phone: +385 (51) 770 447
Fax: +385 (51) 686 166
www.intechopen.com

InTech China

Unit 405, Office Block, Hotel Equatorial Shanghai
No.65, Yan An Road (West), Shanghai, 200040, China
中国上海市延安西路65号上海国际贵都大饭店办公楼405单元
Phone: +86-21-62489820
Fax: +86-21-62489821

© 2011 The Author(s). Licensee IntechOpen. This chapter is distributed under the terms of the [Creative Commons Attribution-NonCommercial-ShareAlike-3.0 License](#), which permits use, distribution and reproduction for non-commercial purposes, provided the original is properly cited and derivative works building on this content are distributed under the same license.

Seed Storage Proteins; Strategies for Developing Crops Promoting Human Health

Nobuyuki Maruyama¹, Takayasu Motoyama¹,
Masaaki Yoshikawa³, Fumio Takaiwa² and Shigeru Utsumi¹

¹*Graduate School of Agriculture, Kyoto University*

²*National Institute of Agrobiological Sciences*

³*Graduate School of Engineering, Osaka University
Japan*

1. Introduction

Plant seeds contain high amounts of storage proteins. These are classified on basis of their solubility as water-soluble albumins, salt-soluble globulins, alcohol-soluble prolamins, and acid- or alkaline-soluble glutelins (Osborne 1924, Utsumi, 1992). The compositions of seed storage proteins differ among plant species. For examples, monocot seeds contain mainly glutelins and prolamins (Ogawa et al., 1987; Li & Okita, 1993; Cagampang et al., 1966), whereas legume seeds contain mainly 7S/11S globulins (Utsumi, 1992).

Rice is the staple food of approximately half of the population of the world. The major seed storage proteins of rice are glutelins and prolamin, similarly to the other monocots. The seed storage proteins present in rice, however, offer little significant benefit to human physiology. Therefore, improving the nutritional and physiological values of rice would be of benefit to the health of considerable numbers of people. A candidate protein that might be of interest in the context of improving the physiological values of rice is β -conglycinin. The seed storage protein of soybean, β -conglycinin, lowers plasma cholesterol and triglyceride levels in humans (Sirtori et al., 1995; Aoyama et al., 2001). Moreover, β -conglycinin increases adiponectin levels and improves glucose tolerance (Tachibana et al., 2010). The α' subunit of β -conglycinin has LDL-cholesterol-lowering activity (Sirtori and Lovati, 2001) and contains a phagocytosis-stimulating peptide (Tsuruki et al., 2003). Therefore, development of rice that can accumulate β -conglycinin should produce a staple food with several important physiological benefits to human health.

β -Conglycinin has the trimeric structure common to 7S globulins of other plant species and is composed of three subunits, α , α' and β . The α and α' subunits contain an N-terminal extension in addition to a core region common to all the subunits (Maruyama et al., 1998, 2001 & 2004). The β subunit consists of only the core domain. The α and α' subunits and the β subunit are synthesized on polysomes as prepro- and pre-forms, respectively. The signal peptides are co-translationally removed, the polypeptides are N-glycosylated with high-mannose glycans and assemble into trimers in the ER (Yamauchi & Yamagishi, 1979; Utsumi, 1992). They are transported from the ER to the protein storage vacuoles through the Golgi apparatus (Mori et al., 2004). The pro regions of the α and α' subunits are

proteolytically processed to give their mature forms, but processing enzymes are unknown. Both the α and α' subunits contain four cysteine (Cys) residues in their pro regions and one Cys in the mature extension region (Figure 1).

We expressed the α' and β subunits of soybean β -conglycinin in rice to develop a line with the potential to promote human health. The accumulation behavior of β -conglycinin in rice seeds has also been described. Further, we designed a β -conglycinin molecule by protein engineering that is expected to have enhanced physiological functions with regard to promoting human health. We expressed this construct in rice plants. In this chapter, we describe our strategy to develop a novel crop by introduction of soybean seed storage protein.

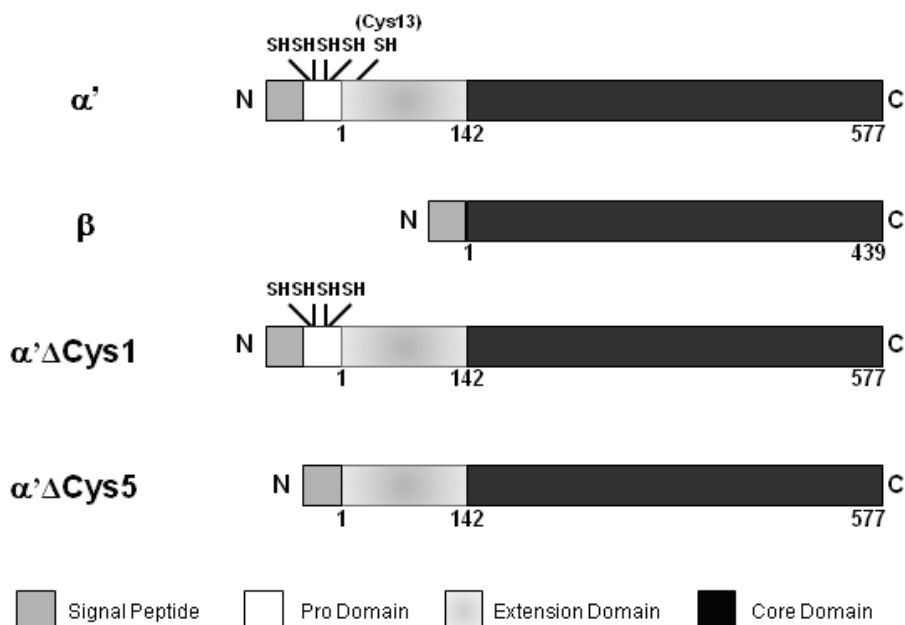

α' , wild type α' subunit; β , wild type β subunit; $\alpha'\Delta\text{Cys}1$ and $\alpha'\Delta\text{Cys}5$, modified versions of the α' subunit. SH indicate positions of cysteine residues. This figure is modified from Motoyama et al. (2009) with permission

Fig. 1. Schematic presentation of the structure of wild-type and mutated β -conglycinin subunits.

2. Transgenic rice producing β -conglycinin in seeds

2.1 Development of transgenic rice seeds accumulating α' and β subunits

cDNAs of the α' and β subunits driven by the rice glutelin *GluB-1* and *GluB-2* promoters, respectively (Takaiwa et al., 1996), were introduced into rice calli by *Agrobacterium tumefaciens*-mediated transformation (Goto et al., 1999). The levels of α' and β subunits in total seed protein extracts were estimated immunologically and found to average levels of 3.9% and 2.0%, respectively (Figure 2). The difference in levels of the two subunits was statistically significant.

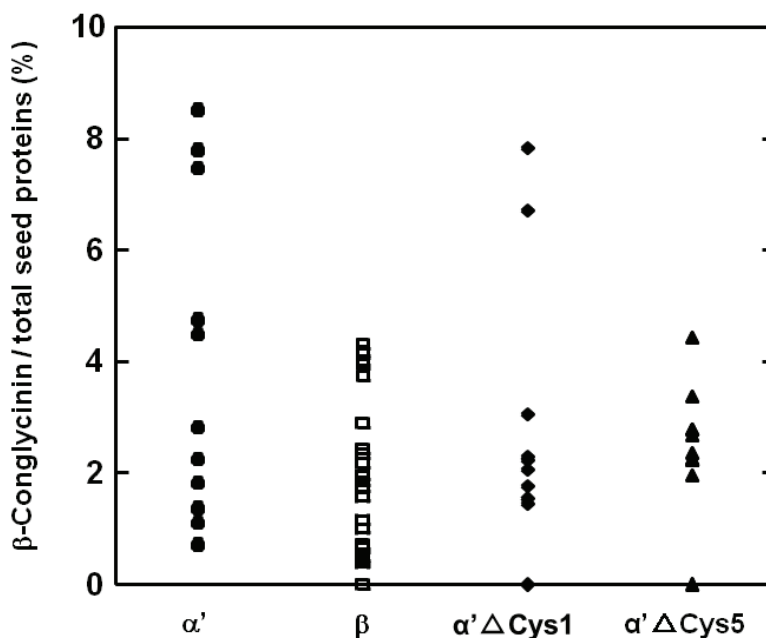

Total protein was extracted from each of the transgenic seeds with SDS buffer. Aliquots (1 μ g/1 μ l) were spotted on a nitrocellulose membrane and the recombinant proteins were detected immunologically with either anti- α' or anti- β sera. Accumulation levels of recombinant proteins were expressed as a percentage of total seed protein. Each mark represents the accumulation level in an independent transgenic plant. This figure is reprinted from Motoyama et al. (2009) with permission.

Fig. 2. Comparison of the accumulation levels of β -conglycinin in transgenic rice seeds.

2.2 Transcription levels of α' and β subunits in rice seeds

The rice lines that exhibited the highest levels of the subunits were self-pollinated to obtain homozygous lines. The α' and β subunits represented 7.9 ± 0.7 and $4.4 \pm 0.8\%$, respectively, of the total rice seed protein extract. Again, the α' subunit accumulated at about twice the rate of the β subunit, similarly to the T₁ seeds. We compared the levels of mRNA of the α' and β subunits by real-time PCR to examine the relationship between mRNA and protein levels. Total RNAs from seeds at 15 days after flowering in the homozygous lines were analyzed and the transcription level of the α' subunit (line 6-2) found to be similar to that of the β subunit (line 5-4), although the α' subunit protein accumulated at about twice the rate as that of the β subunit. Thus, differences in the transcription do not underline the difference in the rate of accumulation of the proteins in rice seeds.

2.3 Post-translational modification of α' and β subunits in rice seeds

Both the α' and β subunits are N-glycosylated with high-mannose type glycans in soybean seeds (Yamauchi & Yamagishi, 1979). To examine whether the α' and β subunits synthesized in rice seeds are also N-glycosylated, the subunits were digested with either PNGase F or Endo H. PNGase F hydrolyzes almost all N-glycans, excluding the core-fucosylated complex

N-glycan, while Endo H primarily hydrolyzes high-mannose glycan but not complex glycan. Prior to the digestions, no degradation products of either the α' or β subunits could be detected by western blotting. Thus, both the α' and β subunits accumulated in a stable fashion in rice seeds. After digestion with the appropriate enzyme, each subunit produced a single band of a lower molecular mass than that of the intact subunit. The analysis suggests that both the α' and β subunits are glycosylated with high-mannose N-glycan, and not with complex glycan.

2.4 Interaction of the α' and β subunits with rice seed storage proteins

We performed a sequential extraction of seed proteins from transgenic seeds using buffer (35 mM sodium phosphate, pH 7.6, 0.4 M NaCl, 1 mM EDTA, 0.02% (w/v) NaN_3) without 2-mercaptoethanol, lactic acid and SDS buffer. Generally, rice glutelin, one of the major types of seed storage proteins in rice, can be extracted by lactic acid but not by buffer (Tanaka et al., 1980; Katsube et al., 1999). We found that most of the β subunit was extracted by the buffer without 2-mercaptoethanol. In contrast, a large amount of the α' subunit was extracted by the lactic acid in addition to the buffer without 2-mercaptoethanol. The α' subunit extracted by the lactic acid exhibited several bands on an SDS-PAGE gel in the absence of 2-mercaptoethanol, whereas, in its presence, only one band appeared. We subjected this fraction to two-dimensional electrophoresis (without/with 2-mercaptoethanol). Most of the stained proteins in the first dimension were identified as glutelins in the second dimension, while the α' subunit exhibited several bands. The major band of the α' subunit might be derived from a complex formed by the α' subunit and rice acid-soluble proteins in first dimension. Other bands of the α' subunit were also detected in the high-molecular mass region. Glutelins were detected in a region of molecular mass higher than the monomer of the α' subunit. These results suggest that some of the α' subunit forms one or more disulfide bonds with glutelin.

2.5 Role of cysteine residues in the α' subunit

To study the role of Cys residues of the α' subunit (four residues in the pro-region and one residue in the mature subunit) in the accumulation of the subunit in rice seeds, we developed transgenic rice producing $\alpha'\Delta\text{Cys1}$ or $\alpha'\Delta\text{Cys5}$ (Figure 1). On average, $\alpha'\Delta\text{Cys1}$ and $\alpha'\Delta\text{Cys5}$ comprised 3.2 and 2.5%, respectively, of total rice seed proteins (Figure 2). More than 90 % of the total $\alpha'\Delta\text{Cys1}$ and $\alpha'\Delta\text{Cys5}$ of transgenic rice seeds could be extracted with the buffer without 2-mercaptoethanol, similar to the β subunit. Further, $\alpha'\Delta\text{Cys1}$ and $\alpha'\Delta\text{Cys5}$ formed the expected assembly in transgenic rice seeds. Therefore, the higher levels of accumulation of the α' subunit compared to the β subunit might not be due to a disulfide bond interactions with glutelin.

2.6 Transgenic rice crosses producing both the α' and β subunits in seeds

Transgenic rice seeds with seeds exhibiting high levels of the α' and β subunits were selected to develop transgenic lines with increased accumulation of both subunits. Total proteins of F1 seeds were extracted with SDS buffer. Transgenic rice producing only the α' subunit, or the β subunit, or both α' and β subunits were identified, and non-transgenic rice was also obtained. The levels of the α' and β subunits in the co-expression lines were compared with those in a single expression line. In co-expression lines, the level of the α'

subunit was about 15% lower than that in the transgenic rice producing only the α' subunit. By contrast, the level of the β subunit in the co-expression lines was about 60% higher than in the transgenic rice producing only the β subunit. A homozygous transgenic rice line that produced both the α' and β subunits was obtained and used for further analysis. In this line, the levels of the α' subunit were approximately 5.2 % and 5.4%, respectively, of those in transgenic rice producing only the α' subunit or producing both α' and β subunits. Similarly, the levels of the β subunit were approximately 3.3% and 5.5%, respectively, of those in transgenic rice producing only the β subunit or both α' and β subunits. The overall level of the α' and the β subunits in transgenic rice producing both the α' and β subunits was approximately 10%. Therefore, co-expression of the α' and β subunits increased the rate of accumulation of β -conglycinin as compared to transgenic rice seeds producing a single subunit of β -conglycinin.

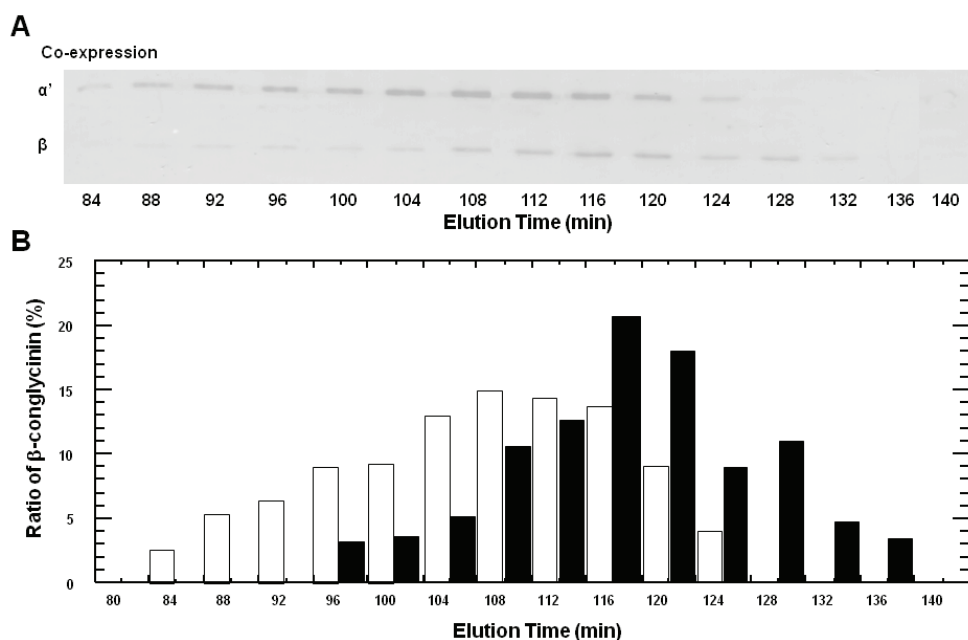

A; The α' and β subunits were extracted with a buffer (35 mM sodium phosphate, pH 7.6, 0.4 M NaCl, 1 mM EDTA, 0.02% (w/v) NaN_3) with 2-mercaptoethanol from rice seeds co-expressing both subunits and subjected to Sephacryl S-300 HR column. Fractions were collected every 4 min. The fractions from 84 to 140 min were subjected to SDS-PAGE followed by western blotting.

B; Summary of the results of western blot analysis of seeds of rice co-expressing both subunits. White and black bars indicate the α' and β subunits, respectively. The figure is reprinted from Motoyama et al. (2010a) with permission.

Fig. 3. Analysis of molecular assembly of the α' and β subunits by gel filtration column chromatography

Soybean seeds contain three subunits of β -conglycinin that form homo- and hetero-trimers in random combinations (Maruyama et al. 2002a and 2002b). To investigate whether the α' and β subunits of transgenic rice assembled into heterotrimers, extracts from seeds obtained

using buffer with 2-mercaptoethanol was analyzed by the gel filtration chromatography (Figure 3). In transgenic rice producing only the α' subunit, homo-trimeric α' subunit was detected in eluates between 96 and 112 min. While a homotrimeric β subunit was detected in eluates between 124 and 136 min in transgenic rice producing only the β subunit. By contrast, the α' subunit in transgenic rice producing the α' and β subunits was detected from 84 to 124 min with peaks at 108 and 112 min and the β subunit was detected in eluates from 96 to 136 min with a peak at 116 min. The α' and β subunits in transgenic rice seeds producing both the α' and β subunits exhibited wider ranges of elution compared to transgenic rice producing a single subunit. This indicates that heterotrimers composed of the α' and β subunits are present in the transgenic rice producing both the α' and β subunits. The α' and β subunits in transgenic rice producing both the α' and β subunits were sequentially extracted from transgenic rice seeds by buffer without 2-mercaptoethanol, 1% lactic acid and SDS buffer. The lactic acid extraction solubilizes glutelins and the α' subunit linked to glutelin. Three intense bands corresponding to the α' and β subunits were observed in the extract of the buffer without 2-mercaptoethanol. Multiple bands corresponding to the α' subunit were detected in the extract with the lactic acid. An interaction between rice acid soluble proteins (mainly glutelin) and the α' subunit via a disulfide bond might occur in transgenic rice producing the α' and β subunits, similar to that observed in plants producing only the α' subunit.

2.7 Subcellular localization of β -conglycinins in rice seeds

Rice seeds have two types of protein bodies, termed PB-I and PB-II (Oparka & Harris, 1982; Tanaka et al., 1980; Yamagata, & Tanaka, 1986; Krishnan & White, 1995). PB-I are derived from the ER, PB-II from the vacuole. β -Conglycinin is known to accumulate in the vacuole (Mori et al., 2004). The subcellular distributions of the α' subunit, the β subunit, $\alpha'\Delta$ Cys1 and $\alpha'\Delta$ Cys5 in transgenic rice seeds were analyzed by transmission electron microscopy. PB-II showed a uniform electron density in non-transgenic seeds. However, in mature seeds of transgenic rice producing the α' subunit, the electron density of the entire PB-II was high and the α' subunit was detected only in the peripheral region of PB-II. By contrast, regions of low electron density regions in the PB-II of mature seeds of transgenic rice producing the β subunit; the β subunit was localized in these regions. In mature seeds of transgenic rice producing $\alpha'\Delta$ Cys1 or $\alpha'\Delta$ Cys5, low density regions were formed in PB-II similarly to transgenic rice producing the β subunit. $\alpha'\Delta$ Cys5 was located only in the low density regions, whereas $\alpha'\Delta$ Cys1 was found in both low- and high-density regions. These results indicate that the pro region of the α' subunit affects protein distribution within PB-II.

We compared the distributions of the α' and β subunits with glutelin in a developing seeds. Glutelin was located in the PB-II of transgenic rice seeds producing the α' subunit and was co-localized with the α' subunit in the periphery of the PB-II. Regions of low and high electron density were observed in the developing seeds of the transgenic rice that produced the β subunit, similar to those observed in the mature seeds. Glutelin did not localize with the β subunit in the PB-II. The patterns of distribution of $\alpha'\Delta$ Cys1 and $\alpha'\Delta$ Cys5 were similar to those in mature seeds. Glutelin was observed in the high electron density regions, and not the low electron density regions, in transgenic rice seeds producing $\alpha'\Delta$ Cys1 or $\alpha'\Delta$ Cys5. These results, together those of the sequential extraction experiment, suggest that the α' subunit might interact with glutelin via the pro region in transgenic rice seeds and that this interaction plays an important role on the localization of the α' subunit within the PB-II.

In addition, we examined the accumulation of α' and β subunits in developing seeds of transgenic rice producing both subunits. In seeds at 10 days after flowering, a low electron density region in PB-II was observed. The α' and β subunits were both present in the low electron density regions, although the α' subunit was located outside of this region. In contrast, the β subunit did not localize outside of the low electron density region of the PB-II. It is possible that homotrimers of the α' subunit in seeds of transgenic rice producing both the α' and β subunits might accumulate outside of the low electron density region of the PB-II.

3. Transgenic rice with a high phagocytosis stimulating activity

3.1 Design of β subunit with a high phagocytosis stimulating activity

A phagocytosis-stimulating peptide (MITLAIPVKNKGR) was isolated from trypsin digested soybean proteins and named soymetide-13 (Tsuruki et al., 2003). Soymetide-13 corresponds with a fragment of the α' subunit of β -conglycinin. Although the N-terminus of soymetide-13 is not formylated, it acts as an agonist of the *N*-formyl-methionyl-leucyl-phenylalanine (fMLP) receptor present on the surfaces of neutrophils and macrophages (Tsuruki et al., 2003; Williams et al., 1977). fMLP is strongly chemotactic for neutrophils (Showell et al., 1976). The fMLP receptor stimulates phagocytosis and mediates the generation of reactive oxygen species in neutrophils and macrophages (Tsuruki et al., 2003). Replacement of the third residue from the N-terminus of soymetide-13 with Trp ([Trp³]-soymetide-13) resulted in a significant increase in affinity for the fMLP receptor (Tsuruki et al., 2004). On the other hand, the β subunit of β -conglycinin has an analogous sequence (IIKLAIPVKNKGR) to soymetide-13. However, it lacks phagocytosis-stimulating activity, because its N-terminus is not methylated. To introduce the phagocytosis activity into the β subunit, we replaced residues I122 and K124 in the analogous sequence of the β subunit (IIKLAIPVKNKGR) and designed three mutants, I122M/K124T, I122M/K124F and I122M/K124W (Maruyama et al., 2003). First, we constructed model simulations of the three mutants from the three dimensional structure of the β subunit. Root mean square deviation for all the C α atoms in a monomer between the starting and simulated models was around 0.67 Å for all the mutants and the distances of C α atoms between the wild type and the simulated models at positions 122 and 124 were 0.47-0.49 and 0.29-0.50 Å, respectively, in all mutants. These values suggest that all the mutants could fold correctly. To confirm this conclusion, we characterized the structural features of the mutants after expression in *E. coli*. No significant differences in circular dichroism spectra were observed between the wild type and the mutants. Measurement of T_m values by differential scanning calorimetry yield values for the mutants that were 1.9-3.1 °C lower than the wild type. Although there is a hydrogen bond between Lys124 and Tyr109 in the β barrel of the wild type, all of the mutants lost this hydrogen bond by the replacement of Lys124. Therefore, the loss of the hydrogen bond of the mutants might induce the slight decrease in T_m values. In gel filtration chromatography, all of the mutants eluted similarly to the wild type. We also determined the crystal structure of I122M/K124W to investigate the effect of the induced change in detail, since Trp was largest of the introduced residues. The C α distances at the residues 122 and 124 between the wild type and I122M/K124W were 0.48 Å and 0.17 Å, respectively. No unfavorable van der Waals interactions were found between the side chains of the replaced residues and neighboring residues. These results indicate that the replacement had little influence on backbone structures and that our conclusions on the conformation of I122M/K124W from

the simulated model are correct. Further, all of the mutants exhibited phagocytosis-stimulating activity in the order of I122M/K124T < I122M/K124F < I122M/K124W as expected, whereas the wild type did not. These results indicate that I122M/K124W has a higher phagocytosis stimulating activity than the α' subunit.

3.2 Development of transgenic rice with a high phagocytosis stimulating activity

To develop a rice line with high phagocytosis stimulating activity, the cDNA for I122M/K124W driven by the rice glutelin *GluB-2* promoter was introduced into the rice genome. The highest level of accumulation of I122M/K124W was 4.1 % of total rice seed proteins, a level similar to that of the β subunit in transgenic rice (Motoyama et al., 2010b). The I122M/K124W was extracted in a salt-soluble fraction from transgenic rice seeds in a similar fashion to the β subunit. An electron microscopic analysis showed that I122M/K124W was located in a low electron density region in the PB-II of mature transgenic rice seeds. The β subunit was also localized to these regions, as described above. These observations indicate that the modification of the β subunit did not affect accumulation or localization in rice seeds.

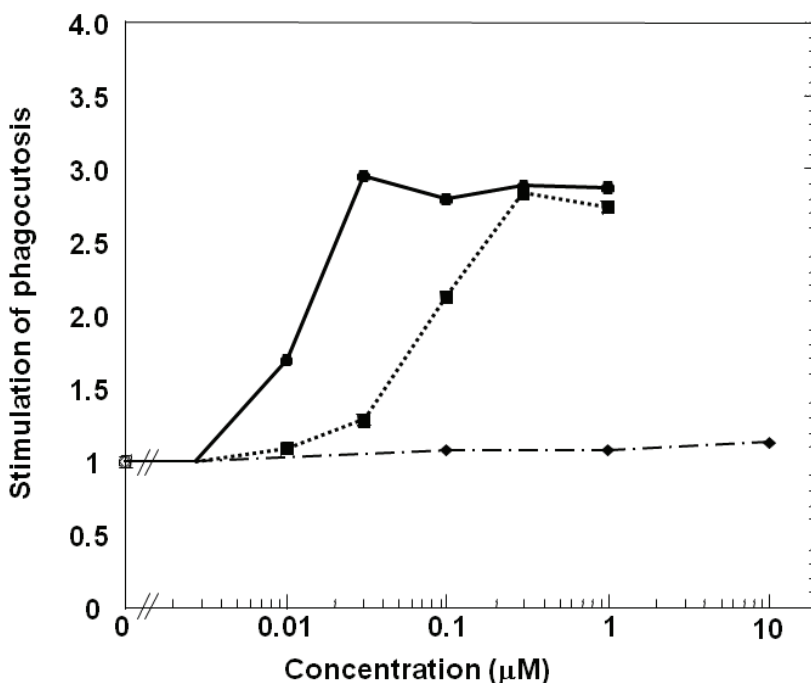

The solid line represents I122M/K124W purified from transgenic rice; the dotted line represents I122M/K124W purified from *E. coli*; the dashed and dotted line represents the wild type of the β subunit purified from transgenic rice. The horizontal axis indicates the final concentration of the wild-type and mutated β subunits in the phagocytosis assay. Protein concentration values before trypsin digestion were used to produce the plot. The figure is reprinted from Motoyama et al. (2010b) with permission.

Fig. 5. Comparison of phagocytosis-stimulating activity

To investigate whether the I122M/K124W can assemble into a trimer in rice seeds, as the β subunit does in soybean seeds, we extracted and purified the mutant protein from transgenic rice seeds and subjected it to gel filtration chromatography. The I122M/K124W peak eluted at a similar time as the homotrimer of the β subunit prepared from soybean seeds and from transgenic rice seeds producing the wild type of the β subunit. Purified I122M/K124W was digested by PNGase F and/or Endo H. After digestion, the I122M/K124W yielded a single band on SDS-PAGE with a molecular mass lower than that of the intact subunit.

The difference in mobility between glycosylated and non-glycosylated β subunits on SDS-PAGE is consistent with results of the wild type (Motoyama et al., 2009). Our analyses indicate that the I122M/K124W in the transgenic rice seed folds correctly, assembles into a trimer, and is modified by attachment of N-linked glycans similarly to the β subunit in soybean seeds.

Trypsin-digested peptides from wild-type and I122M/K124W produced in transgenic rice were assayed for their effect on phagocytosis activity. In addition, we produced I122M/K124W produced in *E. coli* was used for comparison to that purified from the transgenic rice seeds. The rice-derived I122M/K124W exhibited a high phagocytosis-stimulating activity, whereas the wild-type of β subunit purified from transgenic rice seeds had a barely detectable level of activity (Figure 5). Moreover, the phagocytosis-stimulating activity of the rice-derived I122M/K124W was higher than from *E. coli*. We used trypsin digestion and subsequent HPLC analysis to analyze the yield of [Trp³]-soymetide-13 from I122M/K124W produced in rice seeds and in *E. coli*. The yield of [Trp³]-soymetide-13 by the rice-derived protein was estimated as 35.2 %, while that from *E. coli* was 7.7 %. The presence of the glycan on rice-derived I122M/K124W produced a higher solubility at neutral pH compared to that produced in *E. coli*. This might be due to a relatively higher yield of the phagocytosis-stimulating peptide, thereby causing apparent increase in its activity.

4. Conclusion

It has been reported that β -conglycinin has many physiological functions. Plasma cholesterol and triglyceride levels are decreased in rats fed 20 mg/(kg body weight)/day of the α' subunit (Duranti et al., 2004). This is the equivalent of 1.2 g/(60kg body weight)/day of α' subunit in humans. The maximum accumulation level of the α' subunit was about 8% of total seed protein, and the rice seed proteins account for 7% of the total dry weight of rice seed. The average daily consumption of rice in Japan is 150g, which will therefore contain about 0.84 g of the α' subunit. To increase the levels of the α' subunit to provide a greater physiological effect, then an increase by a factor of 1.5 would be necessary. It was reported that a mutant rice variety with low seed storage protein mutant variety is a good platform for the production of foreign proteins (Tada et al., 2003; Wakasa et al., 2007). We plan to utilize a rice variety lacking some glutelin subunits, but with a delicious taste, to develop rice producing β -conglycinin at a high amount. Moreover, multiple introductions of bioactive peptide into β -conglycinin by protein engineering can fortify physiological values. In the future, this strategy could be used to develop transgenic rice that can prevent lifestyle-related diseases and promote a human health in developed countries.

This work was supported by Ministry of Education, Culture, Sports, Science (to S.U. and N.M.) and the Ministry of Agriculture, Forestry, and Fisheries of Japan (Genomics and Agricultural Innovation) (to F.T., S.U. and N.M.).

5. References

- Aoyama, T., Kohno, M., Saito, T., Fukui, K., Takamatsu, K., Yamamoto, T., Hashimoto, Y., Hirotsuka, M. & Kito, M. (2001) Reduction by phytate-reduced soybean β -conglycinin of plasma triglyceride level of young and adult rats. *Biosci. Biotechnol. Biochem.* 65, 1071-1075.
- Cagampang, G.B., Perdon, A.A. & Juliano B.O. (1976) Changes in salt-soluble proteins of rice during grain development. *Phytochemistry* 15, 1425-1429.
- Duranti, M., Lovati, M.R., Dani, V., Barbiroli, A., Scarafoni, A., Castiglioni, S., Ponzone, C. & Morazzoni, P. (2004) The α' subunit from soybean 7S globulin lowers plasma lipids and upregulates liver beta-VLDL receptors in rats fed a hypercholesterolemic diet. *J. Nutr.* 134, 1334-1339.
- Goto, F., Yoshihara, T., Shigemoto, N., Toki, S. & Takaiwa, F. (1999) Iron fortification of rice seed by the soybean ferritin gene. *Nat Biotechnol.* 17, 282-286.
- Katsube, T., Kurisaka, N., Ogawa, M., Maruyama, N., Ohtsuka, R., Utsumi, S. & Takaiwa, F. (1999) Accumulation of soybean glycinin and its assembly with the glutelins in rice. *Plant Physiol.* 120, 1063-1073.
- Krishnan, H.B. & White, J.A. (1995) Morphometric analysis of rice seed protein bodies. *Plant Physiol.* 109, 1491-1495.
- Li, X. & Okita, T.W. (1993) Accumulation of prolamines and glutelins during rice seed development: a quantitative evaluation. *Plant Cell Physiol.* 34, 385-390.
- Maruyama, N., Katsube, T., Wada, Y., Oh, M.H., Barba De La Rosa, A.P., Okuda, E., Nakagawa, S. & Utsumi, S. (1998) The roles of the N-linked glycans and extension domains of soybean β -conglycinin in folding, assembly and structural features. *Eur. J. Biochem.* 258, 854-862.
- Maruyama, N., Adachi, M., Takahashi, K., Yagasaki, K., Kohno, M., Takenaka, Y., Okuda, E., Nakagawa, S., Mikami, B. & Utsumi, S. (2001) Crystal structures of recombinant and native soybean β -conglycinin β homotrimers. *Eur. J. Biochem.* 268, 3595-3604.
- Maruyama, N., Mohamad Ramlan, M.S., Takahashi, K., Yagasaki, K., Goto, H., Hontani, N., Nakagawa, S., & Utsumi, S. (2002a) The effect of the N-linked glycans on structural features and physicochemical functions of soybean β -conglycinin homotrimers. *J. Am. Oil Chem. Soc.* 79, 139-144.
- Maruyama, N., Mohamed Salleh, M.R., Takahashi, K., Yagasaki, K., Goto, H., Hontani, N., Nakagawa, S. & Utsumi, S. (2002b) Structure-physicochemical function relationships of soybean β -conglycinin heterotrimers. *J. Agric. Food Chem.* 50, 4323-4326.
- Maruyama, N., Maruyama, Y., Tsuruki, T., Okuda, E., Yoshikawa, M. & Utsumi, S. (2003) Creation of soybean β -conglycinin β with strong phagocytosis-stimulating activity. *Biochim. Biophys. Acta*, 1648:99-104.
- Maruyama, Y., Maruyama, N., Mikami, B. & Utsumi, S. (2004) Structure of the core region of the soybean β -conglycinin α' subunit. *Acta Crystaogr. D Biol Crystalogr.* 60, 289-297.
- Mori, T., Maruyama, N., Nishizawa, K., Higasa, T., Yagasaki, K., Ishimoto, M. & Utsumi, S. (2004) The composition of newly synthesized proteins in the endoplasmic reticulum determines the transport pathways of soybean seed storage proteins. *Plant J.* 40, 238-249.

- Motoyama T, Maruyama N, Amari Y, Kobayashi K, Washida H, Higasa T, Takaiwa F, & Utsumi S. (2009) α' Subunit of soybean β -conglycinin forms complex with rice glutelin via a disulphide bond in transgenic rice seeds. *J. Exp. Bot.* 60, 4015-27.
- Motoyama, T., Okumoto, Y., Tanisaka, T., Utsumi, S. & Maruyama, N. (2010a) Co-expression of alpha' and beta subunits of β -conglycinin in rice seeds and its effect on the accumulation behavior of the expressed proteins. *Transgenic Res.*, in press.
- Motoyama, T., Amari, Y., Tandang-Silvas, M.R., Cabanos, C., Kimura, A., Yoshikawa, M., Takaiwa, F., Utsumi, S. & Maruyama, N. (2010b) Development of transgenic rice containing a mutated beta subunit of soybean beta-conglycinin for enhanced phagocytosis-stimulating activity. *Peptides*. 31, 1245-1250.
- Ogawa, M., Kumamaru, T., Satoh, H., Iwata, N., Omura, T., Kasai, Z. & Tanaka, K. (1987) Purification of protein body-I of rice seed and its polypeptide composition. *Plant Cell Physiol* 28, 1517-1527.
- Oparka, K.J. & Harris, N. (1982) Rice protein-body formation: all types are initiated by dilation of the endoplasmicreticulum. *Planta* 154,184-188.
- Osborne, T.B., London: Longmans, Green (1924).
- Sirtori, C.R. & Lovati, M.R. (2001) Soy proteins and cardiovascular disease. *Curr. Atheroscler Rep.* 3, 47-53.
- Sirtori, C.R., Lovati, M.R., Manzoni, C., Monetti, M., Pazzucconi, F. & Gatti, E. (1995) Soy and cholesterol reduction: clinical experience. *J. Nutri.* 46, 598S-605S.
- Showell, H.J., Freer, R.J., Zigmond, S.H., Schiffmann, E., Aswanikumar, S., Corcoran, B., & Becker, E.L. (1976) The structure-activity relations of synthetic peptides as chemotactic factors and inducers of lysosomal secretion for neutrophils. *J Exp. Med.* 143,1154-1169.
- Tachibana, N., Iwaoka, Y., Hirotsuka, M., Gorio, F. & Kohno, M. (2010) β -Conglycinin lowers very-low-density lipoprotein-triglyceride levels by increasing adiponection and insulin sensitivity in rats. *Biosci. Biotechnol. Biochem.* 74, 1250-1255.
- Tada, Y., Utsumi S, & Takaiwa F. (2003) Foreign gene products can be enhanced by introduction into low storage protein mutants. 1, 411-22.
- Takaiwa, F., Yamanouchi, U., Yoshihara, T., Washida, H., Tanabe, F., Kato, A. & Yamada, K. (1996) Characterization of common cis-regulatory elements responsible for the endosperm-specific expression of members of the rice glutelin multigene family. *Plant Mol. Biol.* 30, 1207-1221.
- Tanaka, K., Sugimoto, T., Ogawa, M. and Kasai, Z. (1980) Isolation and characterization of two types of protein bodies in rice endosperm. *Agric. Biol. Chem.* 44, 1633-1639.
- Tsuruki, T., Kishi, K., Takahashi, M., Tanaka, M., Matsukawa, T. & Yoshikawa, M. (2003) Soymetide, an immunostimulating peptide derived from soybean β -conglycinin, is an fMLP agonist. *FEBS Lett.* 540, 206-210.
- Tsuruki T & Yoshikawa M. (2004) Design of soymetide-4 derivatives to potentiate the anti-alopecia effect. *Biosci. Biotechnol. Biochem.*, 68,1139-1141.
- Utsumi, S. (1992) Plant food protein engineering. *Adv. Food Nutr. Res.* 36, 89-208.
- Wakasa, Y., Ozawa, K. & Takaiwa F. (2007) Agrobacterium-mediated transformation of a low glutelin mutant of 'Koshihikari' rice variety using the mutated-acetolactate synthase gene derived from rice genome as a selectable marker. *Plant Cell Rep.* 26,1567-73.

- Williams, L.T., Snyderman, R., Pike, M.C. & Lefkowitz, R.J. (1977) Specific receptor sites for chemotactic peptides on human polymorphonuclear leukocytes. *Proc. Natl. Acad. Sci. USA.* 74, 1204-1208.
- Yamagata, H. & Tanaka, K. (1986) The site of synthesis and accumulation of rice storage protein. *Plant Cell Physiol.* 27, 135-145.
- Yamauchi, F. & Yamagishi, T. (1979) Carbohydrate sequence of a soybean 7S protein. *Agric. Biol. Chem.* 3, 505-510.

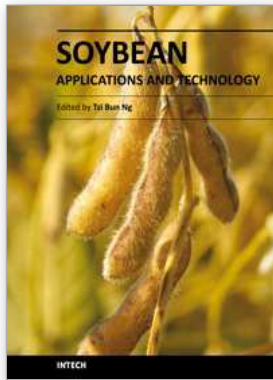

Soybean - Applications and Technology

Edited by Prof. Tzi-Bun Ng

ISBN 978-953-307-207-4

Hard cover, 402 pages

Publisher InTech

Published online 26, April, 2011

Published in print edition April, 2011

Soybean is an agricultural crop of tremendous economic importance. Soybean and food items derived from it form dietary components of numerous people, especially those living in the Orient. The health benefits of soybean have attracted the attention of nutritionists as well as common people.

How to reference

In order to correctly reference this scholarly work, feel free to copy and paste the following:

Nobuyuki Maruyama, Takayasu Motoyama, Masaaki Yoshikawa, Fumio Takaiwa and Shigeru Utsumi (2011). Seed Storage Proteins; Strategies for Developing Crops Promoting Human Health, Soybean - Applications and Technology, Prof. Tzi-Bun Ng (Ed.), ISBN: 978-953-307-207-4, InTech, Available from: <http://www.intechopen.com/books/soybean-applications-and-technology/seed-storage-proteins-strategies-for-developing-crops-promoting-human-health>

INTECH

open science | open minds

InTech Europe

University Campus STeP Ri
Slavka Krautzeka 83/A
51000 Rijeka, Croatia
Phone: +385 (51) 770 447
Fax: +385 (51) 686 166
www.intechopen.com

InTech China

Unit 405, Office Block, Hotel Equatorial Shanghai
No.65, Yan An Road (West), Shanghai, 200040, China
中国上海市延安西路65号上海国际贵都大饭店办公楼405单元
Phone: +86-21-62489820
Fax: +86-21-62489821

© 2011 The Author(s). Licensee IntechOpen. This chapter is distributed under the terms of the [Creative Commons Attribution-NonCommercial-ShareAlike-3.0 License](#), which permits use, distribution and reproduction for non-commercial purposes, provided the original is properly cited and derivative works building on this content are distributed under the same license.

Soybean Seeds Produced in Out Season in West of Paraná State – Brazil

Marizangela Rizzatti Ávila, Alessandro de Lucca e Braccini,
Leandro Paiola Albrecht and Carlos Alberto Scapim
*Department of Agronomy, State University of Maringá, 5790,
Av. Colombo, CEP 87020-900, Maringá, Paraná
Brazil*

1. Introduction

The soybean [*Glycine max* (L.) Merrill], a legume cultivated by the Chinese during approximately 5000 years, was introduced in Brazil by the end of the 19th century, with great agricultural repercussions as from the end of the 1940s (Marcos Filho et al., 1982). Since it is a vastly applicable species, it has been cultivated extensively throughout the country and at present is one of the main agricultural activities with great relevance in agribusiness. In fact, huge investments have been made and high technological progress has been developed for the increase of its production.

In fact, soybean culture growth in the 1970s has changed the style of traditional agricultural activities in Brazil with developments in production based on modern policies in agriculture and prime matter processing industries. Soybean culture was the main trigger within the Brazilian concept of agribusiness not merely in production volume and in economical aspects in the production chain, but also within the business vision of the rural entrepreneur, suppliers of fertilizers and agro-industrial products so that the sector's competitive advantages may be maintained and broadened.

Soybean is of great importance in the Brazilian production system especially in grain production and in exports mainly for the Chinese market.

In the 2008-2009 harvest, soybean world production reached 210.6 billion tons in an area of 96.3 million hectares. However, the USA is the greatest world soybean producer with 80.5 million tons and a cultivated area of 30.2 million hectares, featuring a mean productivity of 2,666 kg ha⁻¹. Brazil comes second with a production of 57.1 million tons and a cultivated area of 21.7 million hectares, featuring a mean productivity of 2,629 kg ha⁻¹ (Companhia Nacional de Abastecimento, 2010). It is expected that the 2009-2010 harvest will reach 64.7 millions of tons.

Soybean is produced in all Brazilian states. The state of Mato Grosso is currently the prime producer, featuring 17.963 million tons in an area of 5.8 million hectares and a mean productivity rate of 3,082 kg ha⁻¹; the state of Paraná comes next, with a production of 9.510 millions of tons in an area of 4.1 million hectares and mean productivity of 2,337 kg ha⁻¹ (Companhia Nacional de Abastecimento, 2010).

Such world and national production rate is due to the fact that the legume is the main source of oil production and vegetal protein for human nutrition. It should further be

enhanced that soybean may have a functional food role since it may be consumed as flour, milk, textured protein, juice, vitamin, mayonnaise, cream, chocolate, vitamin supplements, soybean salad, roasted and in the manufacture of cakes, biscuits, bread, among others. It is highly important in animal feed especially for the confection of rations for fish, cats, dogs, swine, cattle and birds. It is also used in the industrial manufacture of insecticides, ink, varnishes, soap, cosmetics and other products. Its most promising use, however, will probably be the sustainable fuel called bio-diesel.

Innovatory technologies to enhance soybean culture yield should be sought owing to agro-technological issues coupled to knowledge of nutrition and water requirements and the use of high productive cultivars which are tolerant or resistant to diseases and adapted to the most diverse soil and climate conditions.

Since seeds have an important role within the production system, their production, featuring high physiological and sanitary quality, is of primary importance. Guidelines and strategies should be established so that great quantities of high quality seeds could be obtained to attend to the regional demands of every region.

In the wake of the above considerations, the adaptation of soybean culture within the low productivity period may be very promising even though management still lacks technical and scientific consolidation.

2. Quality and productivity of soybean seed produced during the normal crop period and in the winter

To meet the existing agroindustrial demand for soybean cultivation, quality seed must be available to the market to meet production.

The national production of soybean seed in the 2006/2007 crop season was 959,517 tons for a planted area of 20,693,500 ha, while the demand for seeds for the 2007/2008 crop season was 1,273,146 tons for a planted area of 21,219,100 ha (ABRASEM, 2010).

The seed is considered the most important agricultural input since it is responsible for bringing the genetic characteristics of cultivar performance to the field; at the same time, it is responsible for establishing the desired plant stand, which is the basis for high productivities (Marcos Filho, 2005).

Years of research and genetic improvement are being dedicated all over the world to developing this essential input, the seed, because it transmits specific and desirable characteristics for obtaining higher production and productivity at the smallest possible cost.

Producing seeds obliges the producer to be technically efficient and plan and sell efficiently in order to run a successful business.

Seed production starts with choosing the ideal location, principally in relation to the climate. In this respect, South Brazil, with its many localities distributed throughout the states of Paraná, Santa Catarina and Rio Grande do Sul, is privileged to have cooler temperatures than other regions of the country during flowering, maturation, harvesting and storage of seeds.

Other states also produce soybean seed since they have areas suitable for production, for example, the states of Mato Grosso, Bahia, Goiás, Minas Gerais and São Paulo; however, seed production in these states is insufficient to meet the demand of the planted area.

The fact that soybean seed production is concentrated in some states, together with the small differences between the most suitable sowing periods for each state, favors the exchange of

seeds. This means there is a constant flow of seeds between them. This seed flow is especially seen in those states with smaller seed productions, such as Tocantins, Maranhão and Piauí, which are also soybean producers, but do not have a suitable climate for producing soybean seeds and, thus, the seed sown in these states originates from other states.

The preferred crop cycle for multiplying soybean seed in Paraná state has been between October and March, with a field permanence, from sowing to harvest, of 100 to 120 days, depending on the cultivar used to multiply the seeds. The sowing period is variable and follows the agricultural zoning recommended for high quality seed production for each state.

Seed quality can be defined as the group of characteristics which determines its value for sowing, meaning that the potential performance of seeds can only be consistently identified when the interaction of the genetic, physical, physiological and sanitary attributes is considered (Marcos Filho, 2005).

Genetic quality is related to the genetic purity of the soybean seed because this will guarantee that the inherent characteristics of the material to be multiplied will be maintained and expressed in subsequent crops.

Physical quality refers to the physical condition of the seed, which is harmed by the presence of seeds from other species and by inert substances. Stink bug attack, prolonged droughts, high temperatures during maturation, mechanical damage during harvesting and, also, the association of these factors, can affect the physical quality of the material harvested and, consequently, result in a reduction of germination and vigor.

The physiological quality of a seed is its capacity to perform vital functions, characterized by germination, vigor and longevity (Bewley & Black, 1994).

Sanitary quality refers to the presence of microorganisms in the seed, which can contaminate it in the field or during storage.

Among the four quality attributes of seed, those which most influence the seed production system and the quality standards are the physiological and the sanitary.

The physiological quality of soybean seeds can be influenced in the production stage, by the environmental conditions experienced by plants during maturation, post-maturation and pre-harvest, and also by genetic factors. There are references to both biotic and abiotic factors. High temperatures and water stress are the main ones cited, or both together associated with a certain phenological stage. Also insect attack, mainly stink bugs, and disease attack, as well as post-harvest and in the cleaning, drying, storage and transport stages.

The point of physiological maturity of soybean seed, that is, stage R₇, would theoretically be the most suitable for harvesting the seed since it is the point when the best physiological quality is obtained, with maximum viability and vigor. In this stage, the seed moisture content is very high (above 45%) and, after this stage, seed quality will decline due to deterioration.

It is recognized that the maximum quality of soybean seed is attained at physiological maturity, which coincides with the greatest accumulation of dry matter, vigor and germination (Popinigis, 1985). On the other hand, the deterioration process starts at physiological maturity, which is aggravated when seed moisture is reduced below 25%.

Deterioration can be defined as a process which involves cytological, biochemical and physical changes which, eventually, cause seeds to die. The deterioration process in seeds is the principal reason for the loss in viability, which can influence crop yield through a

reduction in germination, resulting in a suboptimum plant population per area and a lower performance of the surviving plants (Roberts, 1974). This process has been characterized as inexorable and irreversible by Delouche (1982), being minimum during the stage of physiological maturity and variable between seed lots of the same species and cultivar. Such a process is determined by genetic factors, stink bug attack, environmental conditions in the post-maturation/ pre-harvest stages, harvest and cleaning procedures, as well as storage and transport conditions.

According to Tekrony et al. (1980), the level of reduction in the germination and vigor of soybean seeds varied with the sowing period and with the temperature, relative humidity and rainfall during the maturation and harvest stages.

Like Tekrony et al. (1980), various authors have mentioned the existence of conditions which made obtaining seeds with an acceptable quality more difficult (Marcos Filho, 2005), including for example: high temperatures and high rainfall at maturation, water deficit and high temperatures at grain filling, stink bug attack etc.

As the seed nears or passes full maturation, which happens in stage R_s , that is, when 95% of pods have the typical coloration of a mature pod (Fehr et al., 1971), its vulnerability increases and the causes of damage to the seed increase.

Due to the difficulty of harvesting soybean seed at the point of physiological maturity, they remain "stored in the field", at the mercy of biotic and abiotic factors. Therefore, if climatic conditions are favorable during this period, deterioration problems will be much reduced.

When rainfall is heavy, and there are fluctuations between high and low atmospheric relative humidities, with environmental temperature variations, in the period between the physiological maturation (pre-harvest) and harvest, there will certainly be significant losses in the seed's physiological and sanitary quality. This situation is often observed in most of the savanna regions, where tropical climate conditions predominate. However, in those savanna areas where altitudes are more than 700 m, the same climate conditions are not observed, and they are considered as suitable for producing seeds with a high physiological and sanitary quality. Favorable abiotic and biotic factors in pre and post-harvest, together with a suitable process of seed formation, will result in very significant results for the physiological and sanitary performance of these seeds.

The physiological quality of soybean seed is more strictly associated with environmental rather than genetic factors (Marcos Filho et al., 1985). However, Paschal II & Ellis (1978) mention the existence of genetic variability for physiological seed quality between soybean genotypes, which can be used in genetic improvement programs.

Some studies demonstrate the existence of genotypes which show differences in seed physiological quality. Such differences can exist due to the presence of hard seeds, which are partially or totally impermeable to water penetration through the tegument and, consequently, are less susceptible to mechanical damage and adverse weather.

The total or partial impermeability of soybean seeds to water penetration is a characteristic which can be used to produce soybean genotypes more tolerant to adverse climatic conditions, which may be present after physiological seed maturation.

Regarding sanitary quality, it is well known that in subtropical and tropical regions, the occurrence of unfavorable climatic conditions during the final maturation stage of soybeans, is common. Excess rainfall at this stage, associated with high temperatures, often cause serious damage to seed production, which besides the physiological deterioration process due to fluctuations in humidity levels, also show high infection levels, principally of fungi. Thus, because of these conditions, the presence of diseases in the soybean seeds, has been observed and associated with a low physiological quality.

According to França Neto & Henning (1992), the deterioration of soybean seeds is a result of the interaction of processes and physical, physiological and sanitary changes. Popinigs (1985) believes that, among the theories on seed deterioration, fungal attack is considered one of the main causes. Christensen (1972) mentions that fungi can cause seed death due to direct disease attack or as a result of mycotoxin production. Machado (1988), describing the relationship between seed vigor and pathology, mentions that pathogens can affect seed vigor; but, on the other hand, low seed vigor resulting from non-infectious factors. The pathogens *Fusarium semitectum* (pod blight), *Colletotrichum truncatum* (anthracnose), *Peronospora manshurica* (downy mildew), *Rhizoctonia solani* (damping-off), *Phomopsis sojae* (pod and stem blight), attack soybeans and are efficiently transmitted via seeds (Henning, 1984).

Although health is a consequence of external abiotic agents, it is influenced by the seed genotype, which provides it with a greater or lesser tolerance to fungal infection.

The association between seeds and pathogenic microorganisms is established during the vegetative development or in the reproductive stage.

The transmission of diseases by seeds is verified in practically all species which breed sexually and various pathogens adversely affect germination (Marcos Filho, 2005).

High temperatures and humidities during seed maturation and harvest can encourage fungal infections, including *Phomopsis* spp. and *Fusarium* spp., principally *F. semitectum*. According to Yorinori (1986), the occurrence of sucking stink bugs (*Euchistus heros*, *Nezara viridula* and *Piezodorus güildini*), responsible for both direct damage and delaying harvest, help infection by *Phomopsis* spp., *Fusarium* spp. and *Colletotrichum dematium* var. *truncata*.

The most important fungi associated with seed physiological quality, in post-harvest and storage, are the so-called "storage fungi" (Popinigs, 1985). These include mainly species of the genus *Aspergillus* spp. and *Penicillium* spp. Spores and mycelia of these fungi are normally already present on the seed surface when this is stored, that is, they are brought in from the field.

The fungus, *Colletotrichum dematium* var. *Truncata* (giving rise to anthracnose) can cause seed deterioration, seedling death and systemic infection of adult plants. The author points out that *Fusarium semitectum* was present during all the sowing periods in the two crop seasons evaluated. *Fusarium semitectum* is the commonest fungus found on soybean seeds. Some authors consider it a weak parasite or a saprophyte but it was purposely included among the phytopathogenic fungi since it causes problems in laboratory germination, like *Phomopsis* sp. (Henning, 1987). According to Henning (1987) and França Neto & Henning (1992), also cited by Pereira et al. (2000), *Fusarium* spp. can reduce seed germination and its effects can be in addition to those of *Phomopsis sojae*. Among the various *Fusarium* species mentioned, *F. semitectum* is the commonest in soybean seeds in Brazil and, like *Phomopsis* spp., it can affect germination in the standard laboratory test, *Phomopsis* spp. showed a greater incidence during the first sowing period in results from two crop years (due to high humidity at maturation, agreeing with Tekrony (1984).

According to Henning (1987), mechanical damage, and deterioration caused by humidity and damage from stink bugs, are often responsible for poor seed quality and are sometimes associated with *Phomopsis* sp., which causes pod and stem blight.

However, emergence problems in seed lots with a high percentage of *Phomopsis* sp. have not been observed because the fungus makes the evaluation of the germination test in lots with high infection levels more difficult (França Neto & Henning, 1992). This genus has been considered one of the principal causes of seed deterioration.

Pathogens have been cited in the literature as one of the main causes of deterioration, and among the factors which compromise soybean seed quality. Various authors declare that seed health is one of the significant factors in seed performance, and others associate sanitary quality with the climatic conditions present during the crop's final stages (Marcos Filho, 2005). Pereira et al. (2000) state that the physiological and health quality of seeds is influenced by the cultivar and the sowing period.

As mentioned earlier, the quality and productivity of soybean seeds are defined by the interaction between the genotype and the environment and are strongly influenced by crop management.

High productivities are only possible when the environmental conditions are favorable in all the soybean's phenological stages and cultural practices are compatible with economic production. The main management practices which should be considered are: a) sowing during the recommended period for the region; b) choice of the most adapted cultivars for this region; c) use of suitable spacing and densities for these cultivars; and d) monitoring and control of weeds, pests and diseases and a reduction of possible harvest losses to the lowest level (Martins et al., 1999).

On opting for a certain sowing period, the farmer will be choosing a certain combination between the crop phenology and the distribution of climate factors in the producing region, which can result in a high or low yield (Peixoto et al., 2000).

The sowing period is defined by a group of environmental factors, which react among themselves and interact with the plant, promoting variations in the yield and affecting its agronomical characteristics. The environmental conditions which most affect soybean development are: temperature, rainfall, soil moisture and, principally, photoperiod (Câmara, 1991). Cultivars show a large variability regarding their sensibility to sowing date and changes in the crop region (latitudes). For this reason, regional trials, done at different times in the same region are important for evaluating soybean cultivars (Peixoto et al., 2000). For Brazilian conditions, the sowing period varies depending on the cultivar, the region and the environmental conditions of the crop year, generally with a recommended band, which varies from October to December. In general, November has shown better productivity results in those states where soybean cultivation is traditional (Nakagawa et al., 1983).

Due to Brazil's considerable territorial area, determining a standard sowing period for the whole country is unviable. This was proved by Barni & Bergamaschi (1981), who found that the best period to sow soybeans depends principally on the soil temperature for germination, the atmospheric temperature during the whole plant cycle, the photoperiod after emergence and soil moisture at sowing, flowering, maturation and harvest. These data vary considerably between regions.

Based on these results, therefore, it is extremely important that the sowing period in soybeans grown for seed production, principally in tropical and subtropical regions, has high temperatures associated with a high atmospheric humidity and abundant rainfall.

The sowing period of soybeans for seed production should be adjusted so that the physiological maturity of the seeds occurs when temperatures are cooler and rainfall is less.

In general, the best productivity in Brazil is obtained when soybeans are sown between the end of October and mid-November. However, to produce high quality seeds, the best sowing periods are between mid-November and mid-December.

Based on this, research has been done in most of the principal soybean producing states in Brazil with the objective of comparing the quality of seed produced in later periods to that sowed conventionally (in October/ November) and, also, the productivity of different

cultivars. Studies by Pereira et al. (1979), Motta et al. (2002), Ávila et al. (2003), Dallacort et al. (2008), Braccini et al. (2010) in Paraná state; Paolinelli et al. (1984) in Minas Gerais; Tragnago & Bonetti (1984) in Rio Grande do Sul; Nakagawa et al. (1983, 1984, 1986) in São Paulo; Pereira et al. (2000) in Goiás; Costa et al. (1995) in Mato Grosso, evaluated both the quality and the productivity of soybean seed sown at different times (October to December), using different cultivars with groups having a distinct maturation (early, medium and late-maturing varieties).

Most of the authors cited previously mentioned that the seed quality of early-maturing cultivars, grown during the spring-summer period, is normally inferior to that of late-maturing cultivars, grown during the same period. This is because normally the maturation stage of the early and semi early-maturing cultivars, coincides with the period of greatest rainfall and atmospheric relative humidity, which normally leads to higher microorganism attack, thereby reducing the physiological quality of the seeds, which is supported by Miranda et al. (1986).

The explanation of the above is that when early-maturing soybean cultivars are sown during periods which give maximum productivity (October/ November), maturation and harvesting occur in February and the beginning of March. This period often coincides with fluctuations in rainfall and high temperatures, which adversely affects seed quality.

However, independent of the cycle, there is a declining linear tendency for the productivity of the cultivars used, as the sowing date distances itself from the ideal. Experimental results commonly show quadratic response curves when the recommended period for sowing is between the extremes, that is, when sowing is neither anticipated nor late. However, such responses do not always coincide with obtaining maximum seed quality, although relevant studies concentrate on the main crop period ("crop season") and rarely seek to investigate the second crop situation grown between the main summer crops.

Some forecasts made by seed producers for sowing dates during less rainy periods (autumn-winter), indicate that growing soybeans for seed production in the inter-crop (off season) period can be an alternative for obtaining good quality seed, since the rainfall intensity and atmospheric relative humidity are more suitable. This is the case as long as the cultivars used are adapted to the region and show stability and juvenility.

The inconvenient factor is the risk of unfavorable climatic conditions during seed maturation (which can be solved by supplemental irrigation), high stink bug populations and higher rust incidence (solved by efficient agrotechnological management).

In the higher altitude savanna regions, during the inter-crop period, with irrigation and control of the available water, and with suitable temperatures, high quality seed can be obtained. This is possible in some producing regions but there have been no supporting technical-scientific studies, especially after the appearance of soybean rust and the consequent legal restrictions to crop planting.

Another relevant aspect in producing soybean seeds during the inter-crop period is the reduction in seed storage time, since the time between storage and the next sowing will be 8 months, during which time the seed quality obtained in the field should be preserved.

The preservation of seed quality during storage, that is, from harvest until planting, is a fundamental aspect to be considered in the productive process, since the efforts spent in the production stage may not be effective if seed quality is not maintained at least until the sowing period (Oliveira et al., 1999).

In the edaphoclimatic conditions of Paraná state, specifically in the west of the state, Albrecht et al. (2009) made one of the few published studies, which specifically deals with

soybean seed production during the inter-crop period. The authors found that soybeans sown between 15/01 and 15/03 did not produce seeds with a high physiological and sanitary quality. However, for most of the cultivars used, the standard of seed was the same as that stipulated for the genetic seed class and basic seed.

Probably, in the study by Albrecht et al. (2009), the use of seeds from early-maturing cultivars, associated with late planting in the inter-crop period (beginning of March), resulted in low productivity and also low seed quality.

Early or very early-maturing cultivars may not be the best options since because of the photoperiod for the latitude studied, together with a lack of the juvenility characteristic, they may cause an excessive shortening of the cycle.

A very short cycle stops the adequate processing of photoassimilate accumulation in seeds, as well as their adequate formation and development. Also, those crops without any supplemental irrigation and with early-maturing cultivars are more vulnerable to the consequences of stress from water deficits (which also stops the formation of seeds with a high physiological potential).

Therefore, it is probable that the conditions at physiological maturity have been, or will come to be, favorable to planting in the inter-crop period: but, if the water, temperature and photoperiodic needs of the soybean plant are not satisfied to ensure its adequate growth and development, the production of soybean seed with a high physiological performance will be prejudiced.

Another important aspect of producing soybean seeds in the inter-crop period is the certainty of reducing the risk of gene flow between transgenic and conventional cultivars with the same cycle.

Maintaining the genetic attributes of the cultivar whose seeds will be multiplied is fundamentally important in seed production. In this case, attention should be given to the production of transgenic seeds during the same periods as conventional seeds.

An increase in the cultivation of transgenic plants has been observed in the last ten years. The world area of GMO plants is estimated at 80 mm ha, with soybeans resistant to glyphosate herbicide (*Roundup Ready* soybeans - RR), being especially significant, since it is the most widely planted transgenic crop, with approximately 61% of the total world area.

Celeres (2010) estimates that about 75% of the total area sown to soybeans in Brazil in the 2010/11 season will be with transgenic varieties, which generates high demand for seeds.

Included in the norms for producing transgenic soybean seed is a regulation for a minimum isolation distance, which can be either in space or time, between different transgenic cultivars and between transgenic and conventional cultivars, with the aim of avoiding the risk of gene transmission to future generations. This is because of the possible gene flow via pollen (Ray et al., 2003) between one plant and another, to maintain seed purity.

In this context, the possibility of non-transgenic soybeans being pollinated by transgenic cultivars and vice-versa has been raised. A negative answer is immediately obvious since it is known that soybeans are essentially autogamous, with complete flowers, and the masculine and feminine organs protected within a corolla, with fecundation occurring before the flower opens (cleistogamy). However, pollen grains can be dispersed in the environment by entomophily, that is, by insects, principally by bees, among others, which visit the flowers and can transport the pollen and pollinate the flowers of different plants; besides insects, the wind also functions as a pollinating agent and because of this, the rate of cross pollination is generally lower and close to 1% (Borém, 1999). Sedyama et al. (1970) in Viçosa, Minas Gerais state, working with plants in direct contact with each other and with plants very close to one

another, observed a natural crossing of 1.3% and 0.03% respectively. In another study in Capinópolis, Minas Gerais state, a value of 0.9% was observed for rows in direct contact. On the other hand, Verneti et. al. (1972) found the percentage of natural crossing to be 0.03% in Ponta Grossa, Paraná state, and 1.22% in Pelotas, Rio Grande do Sul state.

These studies prove that, under normal field conditions, cross pollination is low (Ahrent & Caviness, 1994) and the variations in the level of cross fecundation are related to the climatic conditions of the crop year, the genotypes, the environment and plant isolation. The values for cross fecundation in soybeans are low and it occurs principally between adjacent plants whose flowering coincides. Nelson & Bernard (1984) observed that an isolation distance of 10 m for soybeans would eliminate almost all pollen contamination. Ahrent & Caviness (1994) demonstrated that the frequency of cross pollination can reach 2.5% in some cultivars and that insect, especially Hymenoptera, can act as pollinators (Erickson et al., 1978).

Results from some studies done over the last three years with non-transgenic soybeans have shown that the occurrence of cross pollination at distances greater than 4.6 m is rare (Ahrent & Caviness, 1994). Boerma & Moradshahi (1975) consider a distance of 7 m safe since cross pollination was 0% at this distance, although obtaining this distance between one seed producing field and another is difficult at present, due to the increase in cultivated soybean area.

The scientific results of genic flow between non-transgenic and transgenic cultivars are very contradictory.

Due to this situation, seed production, principally of the genetic category during the inter-crop period, when large soybean areas are not planted, could be an interesting solution for reducing the risk of gene flow to low levels, considering the sowing period, the presence of insects with pollinating potential, and the velocity and direction of the winds.

The problem is not only field contamination but also the cleaning of the harvesting and cleaning equipment. Winter weed management is another worry, although different crops introduced into the production system through crop rotation, facilitate the use of different herbicides with distinct mechanisms of action, minimizing the selection of resistant weed biotypes.

Strategies which stop soybean crops being planted in succession are indispensable for system sustainability, and improve nutrient cycling, weed control, and the propagation of diseases and pests in the crop.

As long as the no-planting period, regulated by government decrees (with the aim to breaking the “Green bridge” which maintains the asian rust in the environment), is respected, the production of transgenic soybean seeds in certain environments would be extremely valid.

The growing of soybeans, whether it be transgenic or conventional, during the inter-crop period and focusing on seed production, should, besides the respective legislation, respect agronomical criteria which will identify suitable areas and sowing periods. Therefore, edaphoclimatic and phytotechnical studies are needed, considered together with available knowledge (presently scarce), to develop a rational zoning for soybean for the inter-crop period.

3. Ecophysiology and agroclimatic aptitude of soybean production in a second crop

Wherever plants grow, they will be subject to multiple stresses, which will limit their development and chances of survival.

Soybean is a crop which may suffer a range of physiological and morphological changes during development when its ecophysiological needs are not met.

Water availability for soybeans is important, principally in two development periods: germination and emergence; flowering and seed filling. During the first period, both water excess and deficit adversely affect a good uniform plant population. The soybean seed needs to absorb at least 50% of its weight in water to guarantee good germination. In this stage, the soil water content should not exceed 85% of the total water available or be less than 50%.

The water needs of soybeans increase with plant development, reaching a maximum during flowering-grain fill (7 to 8 mm dia⁻¹), and decreasing after this period.

Studies on agroclimatic zoning are primarily developed with the objective of satisfying water demand through the creation of water balances. The aim of agricultural zoning is to identify suitable areas throughout Brazil and recommend when soybean seeds should be sown with the least climatic risk.

In Paraná state, as in other regions, the water balance is estimated by using the following climatic and agronomical variables:

- a. rainfall and temperature: historic series with an average 20 years data are used, with records from 191 rainfall and 29 climatological stations in the state;
- b. potential evapotranspiration: estimated for 10-day periods, by applying the Penman-Monteith method for each climatological station in the state;
- c. crop cycle and phenological stage: the stages of germination/ emergence, growth/ development, flowering/ grain fill and maturation, were considered for simulation purposes. Cultivars were classified into three groups with homogeneous characteristics: Group I ($n < 115$ days); Group II ($115 \text{ days} \leq n \leq 135$ days); and Group III ($n > 135$ days), where n is the number of days from emergence to complete maturation;
- d. crop coefficient: experimental data available from scientifically recognized publications;
- e. maximum availability of soil water: estimated as a function of the effective depth of the roots and soil water capacity.

Soil Types 1, 2 and 3, with a water storage capacity of 30, 50 and 75 mm respectively, are considered. The simulations of water balances are done for 10-day periods.

The mean values of the Satisfaction Index of Water Needs - SIWN (expressed by the relationship between real evapotranspiration and the maximum evapotranspiration - E_{Tr}/E_{Tm}), for sowing date, phenological stage and geographic location of the pluviometric and climatological stations consulted, are considered. The flowering/ grain filling stage was considered the most critical regarding water deficit.

Municipalities are thought suitable when in 20% of their territory the SIWN is greater or equal to 0.65, in at least 80% of the years evaluated.

Zoning is done primarily to minimize the negative impact of water restrictions on plant growth and development. Significant water deficits during flowering and seed maturation cause physiological changes in the plant, such as closure of the stomata and rolling up of the leaves. Consequently, this causes premature leaf and flower abscission and also pod abortion, resulting in less productivity (Santos, 2008).

To obtain a maximum yield, water needs for the soybean plant during its whole cycle vary between 450 and 800 mm, depending on climatic conditions, crop management and cycle length.

Water availability is one of the most important environmental factors for plant growth and development. Water deficit, caused by drought or soil salinity, is one of the most serious environmental problems limiting agricultural production in various regions of the world.

The response of plants to water stress depends on the stage they are in, as well as its severity and duration. Climatization to environmental stress results from integrated events which occur at all organizational levels, from the anatomic and morphological to the cellular, biochemical and molecular. Leaf wilting in response to water deficit reduces water loss from the leaf and also exposure to incident light, thus reducing heat stress to the leaves.

The temperature directly influences all crop stages, that is, germination, growth, flowering and fruiting, as well as respiration, photosynthesis and water and nutrient absorption.

The optimum temperatures for soybeans lie between 20 and 30°C, with 30°C being the ideal temperature for development. The soil temperature range suitable for sowing varies from 20 to 30°C, with 25°C the ideal temperature for rapid and uniform seedling emergence.

The vegetative growth of soybeans is small or nil in temperatures less or equal to 10°C. Temperatures above 40°C adversely affect the growth rate, causing damage to flowering and reducing pod retention capacity. These problems increase with water deficits.

The minimum temperature for the beginning of the reproductive stage of soybeans varies according to the demands of each cultivar, but under Brazilian conditions it is estimated at 13°C, since soybean flowering is only induced at temperatures above this. Maturation can also be accelerated by high temperatures (Santos, 2008).

Maturation can be accelerated by high temperatures. When associated with high humidities, high temperatures can reduce seed quality, and when associated with low humidities, they predispose the seeds to mechanical damage at harvesting. Low temperatures associated with rainfall or high humidity at harvest can delay harvesting as well as cause green stem and foliar retention.

Considering the temperature needs of soybean, and the possibility of stress caused by temperature extremes, it is believed that in order to grow soybeans, besides the water regime, temperature availability in the different crop stages must also be understood. Regarding the possibility of growing crops outside the main crop cycle or between the summer crops, where temperature extremes may be a fact, the climatic temperature variable must be considered when planning the soybean crop. Thinking specifically of the winter crop in southern Brazil, low temperatures may occur after flowering in soybeans planted later, which may limit the viability of productive systems planting soybeans during the winter months.

In the case of soybeans, the climatization of different cultivars to certain regions depends on the photoperiodic needs, as well as on those for water and temperature.

Sensibility to photoperiod varies between cultivars, that is, each cultivar has its own critical photoperiod below which flowering is stimulated. The typical photoperiodic effect in soybeans is a reduction in the period between seedling emergence and the beginning of flowering, and consequently, of the crop cycle. However, cultivars which have a long juvenile period show more adaptability so they can be used in wider bands of latitude (places) and sowing periods.

Therefore, the typical photoperiodic effect in soybeans is a reduction of the period between seedling emergence and the beginning of flowering and, consequently, of the crop cycle, when a cultivar is taken to a lower latitude region or when sowing is delayed. This also results in the formation of shorter plants with insertion of the first pod at a lower level, and reduction of foliar area and productivity (Sediyama et al., 1972).

Soybean cultivation at lower latitudes and outside the conventional period in southern Brazil can result in plants which anticipate flowering, reduce vegetative growth and, consequently, the productive potential. Genetic improvement with the production of

genotypes having a long juvenile period is a strategy which can be used. Therefore, the planting of soybean cultivars with longer cycles as a second crop in Paraná and other southern Brazilian states, preferentially with a juvenile characteristic, is recommended. Based on these assumptions, some farmers have been sowing cultivars normally planted in the Brazilian Savannas (Cerrado region) as a second crop in Paraná, since many of these savanna cultivars (low latitude conditions) have a long juvenile period.

Ecophysiologically, soybeans are demanding for various factors, such as photoperiod, temperature and water. In this context, under natural agricultural conditions, plants are often exposed to environmental stress. The environmental stresses are external factors, which commonly produce adverse effects resulting in low soybean productivities as well as reducing seed quality and oil and protein content.

Considering that the soybean plant is influenced by various factors throughout its cycle, it is relevant to emphasize that crop management can influence plant development and yield, and also seed quality and chemical composition. Examples of management include the sowing period, cultivar selection, choice of plant population, fertilizer levels and pesticide regimes.

Atypical climatic situations in Brazilian agriculture are influenced by phenomena such as La Niña and El Niño, among others.

Based on global warming studies, it is believed that there will be significant changes in agriculture in the world, including Brazil. Research studies in Brazil have forecasted a new geography of agricultural production, indicating an increase in areas unsuitable for growing soybeans (EMBRAPA SOJA, 2008), that is, areas which used to be suitable for the crop, sown in November, December and January (according to the study by EMBRAPA SOJA, 2008), will become unsuitable.

According to EMBRAPA SOJA (2008), soybeans are the crop which should most suffer from global warming if sowing conditions stay as they are and no genetic modifications are made (this should not be the case since new varieties are already being studied). By 2017, the area of low risk in Brazil can be reduced to 60% of the present area, due to the increase in water deficits and the possibility of more intense summer droughts. The southern region and the Northeastern savannas will be the most affected areas.

Changes in global and regional climates have a significant influence on human and economic activities. Studies of the climate variations in the Southern Region of Brazil have analyzed rainfall anomalies (Casarin & Kousky, 1986).

Temperature, rainfall and atmospheric relative humidity are meteorological characteristics which directly influence environmental conditions. The world variation in atmospheric temperature is one of the most important climatic parameters strongly influencing various areas, such as agriculture, fishing, cattle raising, engineering, temperature and urban comfort, and energy production, among others.

Many aspects of agricultural production can be adversely affected by the weather. Fox et al. (1999) believed agricultural forecasting to be very important, principally for rainfall, resulting in the development of forecasting methods. Many researchers have reasoned similarly, developing methods for evaluating when and how much it rains and the yearly rainfall distribution.

Foreknowledge of these elements, the plant's reactions to their availability, and the critical limits in agricultural management practices, are essential for the plant's ecophysiological success (Leal, 2001).

Considering that soybeans are influenced by various factors during their cycle, the choice of when to sow must be considered as the cultural factor, which by itself most influences plant development, crop production and also seed quality.

The sowing period is a factor which affects not only production but also seed performance because it exposes the seeds to climatic factors and is, therefore, a fundamental parameter for obtaining better quality seeds (Costa et al., 1995).

The sowing period can be adjusted to avoid losses from low rainfall during the critical periods of soybean development for moisture, that is, at its establishment, flowering and seed formation (Barni & Bergamaschi, 1981).

Innumerable research studies, which show the importance of defining the sowing period, have been done in various soybean producing areas of Brazil, with the objective of establishing the most suitable sowing period (Motta et al., 2002).

Some studies have indicated that the sowing period should be established so that the seed maturation stage occurs when temperatures and rainfall are less (França Neto & Henning, 1984).

In the climatic conditions of north Paraná state, early maturing soybean varieties, sown at the beginning of October, should mature in the second half of February, which coincides with periods of high temperatures and excess rainfall. This results in seeds with a lower physiological quality and a high degree of deterioration from humidity (Pereira et al., 1979).

Another study by Val et al. (1985) in this same region, which planted nine soybean cultivars at five different sowing periods, demonstrated that, in general, the best sowing period was in mid-November, when most of the cultivars reached their best productivities and plant heights. Anticipating the sowing for September adversely affected the performance of most cultivars, reducing not only the productivity but also plant height and pod insertion.

The influence of the environment on seed development is seen principally in variations of size, weight, physiological quality and health (Marcos Filho, 2005). Experimental studies supply important information, which can be used to differentiate cultivars and indicate the best times for sowing in a certain region for a certain cultivar (Motta et al., 2002).

The preferential period for sowing soybeans in Paraná state is November. In general, for the main producing regions of Brazil, higher productivities are obtained when soybeans are sown between October 15th and December 15th. For most regions, soybeans sown at the end of December and in January can result in yield reductions of between 10 and 40% compared to those sown in November (EMBRAPA SOJA, 2008).

The best results for yield and plant height, in most years and for most cultivars, are obtained for soybeans sown between the end of October and the end of November. In general, soybeans sown in the second half of October produce shorter plants with higher yields compared to those sown in the first half of December. However, in some areas, it is possible to obtain plants of a suitable height with a good yield when seeds are sown in the first half of October (EMBRAPA SOJA, 2008).

For situations where the aim is to plant autumn-winter corn after the soybean crop, the planting of early-maturing soybean varieties is recommended, preferably sowing between the end of October and November 15th. However, the use of early-maturing cultivars can result in shorter plants with an inadequate canopy closure leading to greater weed effects in the crop. This problem can be accentuated if there is a lack of rainfall during the period at

the end of November, beginning of December, which has been common in Paraná state (EMBRAPA SOJA 2008).

According to EMBRAPA SOJA (2005), anticipating sowing would be by planting before October 15th. Crops sown before this date tend to show a longer period between sowing and seedling emergence (due to the low nocturnal temperatures) and also shorter plants, resulting in harvest losses. This can be done in hotter regions of the state, where the winter is humid, soils are extremely fertile and temperatures favor seedling emergence from the beginning of October. These conditions are commoner in the western region of Paraná state, located between the Piquiri and Iguaçu, which are at a lower altitude and closer to the Paraná River.

The second soybean crop in the western region of Paraná state, as well as in other producing regions of Brazil (mainly the savanna region), is a common practice among farmers and can be an option for producing soybean seeds during the offseason or intercrop period (soybeans cultivated during a non-conventional period). Also, if there is no production of commercially acceptable seed, there still remains the possibility of reaching acceptable standards for producing basic seed (75% germination).

However, soybean production under conditions occurring between the summer crops or in the winter suffers from ecophysiological restrictions. Both biotic and abiotic factors can limit the possibility of winter soybeans becoming a second soybean crop and generating significant income, as is the case with corn.

Some productive systems in which soybeans would be sown after soybeans or after dry beans, cotton or sunflower, would be unviable in phytosanitary terms, especially regarding disease incidence in the large crops, such as *Sclerotinia* stem rot (*Sclerotinia Sclerotiorum*) and nematodes.

Asian rust, (*Phakopsora sp.*), is also seen as a real problem, especially when soybeans permit the so-called "green bridge" for the rust inoculum. Diseases such as powdery mildew (*Microsphaera diffusa*) in soybeans can also increase significantly under some climatic conditions in the winter crop, where the climate is warmer and dry. Insects, such as stinkbugs (*Nezara viridula*, *Euschistus heros*, *Piezodorus guildinii* and *Dichelops furcatus*), can be severe problems since they will find an available food source to keep their populations at potentially damaging levels.

In the case of weeds, due to the need for immediately sowing after the summer crop, careful management would be necessary to minimize interspecific competition between weeds and the crop, as well as the perennization of weed species in the field and even the selection of resistant biotypes through the continuous use of herbicides with the same mechanism of action. The solution in this case would be rotation in the area between transgenic and non-transgenic cultivars.

With regard to the abiotic factors, serious restrictions could occur due to low temperatures and water deficits during a second soybean crop cultivated in Southern Brazil. On the other hand, a second soybean crop in the savanna region would only need a water supplement supplied via irrigation because of the sowing season.

The barriers to the development of soybean agroecosystems in the winter months can be solved with strategies which range from the use of suitable sowing periods to the implementation of an efficient and prompt agrotechnological management.

Together with ecophysiological perceptions and the need for suitable technologies for soybean cultivation during the winter months, the advance of research (public and private) in the tropical and subtropical conditions of Brazil is indispensable for soybeans to be a viable option during the intercrop period. This cultivation is important since it is a valid tool for obtaining quality seeds.

4. Perspectives and final considerations

Even after the significant conquests by Brazilian agribusiness with technological advances, which have allowed the expansion and viability of crops, as in the case of soybeans, more progress is still possible due to the existing large potential, whether it is the environment still to be explored or the human capital involved.

One of the greatest examples of the phytotechnical revolution in soybeans is its adaptation to cultivation at low latitudes, through a laborious process of genetic improvement. The rational management of poorer land, which has been making soybean cultivation possible in regions with sandy and low fertility soils, such as in the savanna areas and in the Caiuá sandstone region (northwest Paraná), has also been mentioned. The introduction of transgenic soybean genotypes, especially in the last decade, has motivated a new revolution after the “Green Revolution” (using agrochemical and industrialized inputs), a so-called “Biotechnological Revolution”.

In the currently promising situation for soybeans, among the various agrotechnological questions being considered, the focus is now on production in the interval between the main summer crops, the so-called second crop (“out season”), with the principal aim of obtaining seeds for sowing in the main summer crop (“main season”). However, there is little technical knowledge on soybean cultivation for the second crop since, apart from a few empirical observations by farmers in south Brazil and some savanna areas, few research data are available.

Due to the ecophysiological characteristics of soybeans, such as its water, temperature and photoperiodic needs, more studies are necessary which can develop a suitable agroclimatic zoning for second crop soybeans. These studies would recommend more suitable sowing periods for producing quality seed in the necessary quantities, as well as the selection of genotypes with greater stability-adaptability. Crop management systems must also merit careful attention, since exposed to a differentiated climate when grown as a second crop, adaptations, such as for disease control (e.g. soybean rust), need to be optimized. Irrigation management is another extremely important issue, especially for a second crop in the savanna region, because soybeans may suffer from drought during the reproductive stages.

Second crop soybeans in a crop rotation system can be an extremely valid strategy because it is a legume (with efficient nitrogen fixation) planted in the period between the main summer crops. The use of systems in some savanna areas, such as centre pivot irrigation, should also be mentioned. However, sowing periods should respect the present legislation, which limits cultivation during certain periods, through the mandatory no-planting period (“vazio sanitário”).

If the real possibility of lower temperatures and low humidity during the maturation and harvesting of a second crop in southern areas of Brazil, and at high altitudes in the Brazilian

savannas, are considered, this would be a significant alternative for obtaining healthy seeds with a high physiological quality. Although many farmers have actually been planting a second crop, there are still no consistent results published in the literature which definitively support this possibility. The opportunity to preserve genetic quality through a reduction of gene flow in the second crop should be mentioned, and this is beneficial considering the introduction of GMO.

As well as potentially supplying seed with the desired quality, seed production in the second crop can also use the available infrastructure for cleaning and storing seed, thus reducing its idleness. Seed produced by the second crop would also satisfy much of the regional demand, be stored for less time, subject to fewer quality losses and add value to the productive system of many rural businesses.

In conclusion, second crop soybeans show theoretical and real advantages, which need to be more carefully evaluated. Second crop cultivation, therefore, is valid but still requires to be fully confirmed by agronomical studies.

5. References

- ALBRECHT, L.A. 2009. Tese (Doutorado) - Universidade Estadual de Maringá, Maringá, 2009.100p.
- ABRASEM - ASSOCIAÇÃO BRASILEIRA DE SEMENTES E MUDAS. Anuário ABRASEM 2010. Brasília, 2010. 80p.
- AHRENT, D.K.; CAVINESS, C.E. Natural cross-pollination of twelve soybean cultivars in Arkansas. *Crop Science*, v.34, p.376-378, 1994.
- ÁVILA, M.R.; BRACCINI, A.L.; MOTTA, I.S.; SCAPIM, C.A.; BRACCINI, M.C.L. Sowing seasons and quality of soybean seeds. *Scientia Agricola*, Piracicaba, v.60, n.2, p. 245-252, 2003.
- BARNI, N.A.; BERGAMASCHI, H. Alguns princípios técnicos para a semeadura. In: MIYASAKA, S.; MEDINA, J.C. (Ed.). *A soja no Brasil*. São Paulo: ITAL, 1981. p. 476-480.
- BEWLEY, J. D.; BLACK, M. *Seeds: physiology of development and germination*. 2. ed. New York: Plenum Press, 1994.
- BOERMA, H.R.; MORADSHAHI, A. Pollen movement within and between rows to male-sterile soybeans. *Crop Science*, v.15, p.858-861, 1975.
- BORÉM, A. Escape gênico: os riscos do escape gênico da soja no Brasil. *Biotecnologia, Ciência e Desenvolvimento*, v.10, p.101-107, 1999.
- BRACCINI, A.L.; STÜLP, M.; ALBRECHT, L.P.; ÁVILA, M.R.; SCAPIM, C.A.; RICCI, T.T. Agronomic traits and seed yield produced in the soybean-corn crop in succession cropping. *Acta Scientiarum. Agronomy*, Maringá, v.32, n.4, p.651-661, 2010.
- CÂMARA, G.M.S. Efeito do fotoperíodo e da temperatura no crescimento, florescimento e maturação de cultivares de soja (*Glycine max* (L.) Merrill). 1991. Tese (Doutorado) - Universidade Federal de Viçosa, Viçosa, 1991.
- CASARIN, D. P.; KOUSKY, V. E. Anomalias de Precipitação no Sul do Brasil e Variações na Circulação Atmosférica. *Revista Brasileira. Meteorologia*, v. 1, p. 83-90, 1986.

- CÉLERES. Relatório biotecnologia. Uberlândia, MG. 7p.
- CHRISTENSEN, C.M. Microflora and seed deterioration. In: ROBERTS, E.H. (Ed.). Viability of seeds. Syracuse: Syracuse University Press, 1972. p.59-93.
- CONAB. Soja - Brasil: série histórica de área plantada, produtividade e produção: safras 1976 a 2009/2010 em mil hectares. Brasília, 2010. Disponível em: <http://www.conab.gov.br/conteudos.phpa=1252&t=&Pagina_objcmsconte>. Acesso em: 10 set. 2010.
- COSTA, N.P.; FRANÇA NETO, J.B.; HENNING, A.A.; KRZYZANOWSKI, F.C.; CABRAL, N.T.; MENDES, M.C. Efeito da época de semeadura sobre a qualidade fisiológica de sementes de soja no Estado do Mato Grosso. Revista Brasileira de Sementes, v.17, n.1, p.107-112, 1995.
- DALLACORT, R.; FREITAS, P. S. L.; GONÇALVES, A. C. A.; FARIA, R. T.; REZENDE, R.; BERTONHA, A. Níveis de probabilidade de rendimento de quatro cultivares de soja em cinco datas de semeadura. Acta Scientiarum. Agronomy, v. 30, n. 2, p. 261-266, 2008.
- DELOUCHE, J.C. Physiological changes during storage that affect soybean seed quality. In: SINCLAIR, J.B.; JACKOBS, J.A. (Ed.). Soybean seed quality and stand establishment. [S.l.]: Intsoy, 1982. p.57-66. (Intsoy, 22).
- EMBRAPA. Tecnologias de produção de soja: região central do Brasil - 2008. Londrina: Embrapa Soja; Embrapa Cerrados; Embrapa Agropecuária Oeste, 2008. (Sistemas de Produção, 12).
- EMBRAPA. Tecnologias de produção de soja: Paraná - 2006. Londrina: EMBRAPA Soja, 2005. 208p. (Sistemas de Produção, 8).
- ERICKSON, E.H.; BERGER, G.A.; SHANNON, J.G.; ROBBINS, J.M. Honey bee (Hymenoptera-Apidae) pollination increases soybean yields in Mississippi Delta region of Arkansas and Missouri. Journal of Economic Entomology, v.71, p.601-603, 1978.
- FOX, G., TURNER, J., GISLLESPIE, T. The value of precipitation forecast information in winter wheat production. Agricultural and Forest Meteorology, v.95, 99-111, 1999.
- HENNING, A.A. Testes de sanidade de sementes de soja. In: SOAVE, J.; WETZEL, M.M.V.S. (Ed.). Patologia de sementes. Campinas: Fundação Cargill, 1987. p.441-454.
- HENNING, A.A.; FRANÇA NETO, J.B. Effect of *Phomopsis* spp on soybean seed quality in Brazil. In: Conference on the *Diaporthe/Diaporthe* diase complex of soybean. Fort Walton Beach: Proceeding Springfield, 1984. p.66-67.
- LEAL, L. S. M.; SILVA, M. M.; SANTOS, S. N. M.; MORAES, M.; NETO, O. B.; Análise do Balanço Hídrico e Aptidão Agroclimática para o Cultivo de Soja no Sul do Estado do Pará. In: XII CONGRESSO BRASILEIRO DE AGROMETEOROLOGIA E III REUNIÃO LATINO-AMERICANA DE AGROMETEOROLOGIA, 2001, Fortaleza. Anais..., 201-202p.
- MACHADO, J.C. Patologia de sementes: significado e atribuições. In: CARVALHO, N.M.; NAKAGAWA, J. (Coord.). Sementes: ciência, tecnologia e produção. 3. ed. Campinas: Fundação Cargill, 1988. 424p.

- MARCOS FILHO, J. Fisiologia de sementes de plantas cultivadas. Piracicaba: FEALQ, 2005. 495p.
- MARCOS FILHO, J.; CARVALHO, R.V.; CÍCERO, S.M.; DEMÉTRIO, C.G.B. Qualidade fisiológica e comportamento de sementes de soja (*Glycine max* (L.) Merrill) no armazenamento e no campo. Anais da Escola Superior de Agricultura "Luiz de Queiroz", Piracicaba, v.42, p.195-249, 1985.
- MARCOS FILHO, J.; GODOY, O.P.; CÂMARA, G.M.S. Tecnologia da produção. In: CÂMARA, G.M.S. et. al. Produção, pré-processamento e transformação agroindustrial. São Paulo: Secretaria da Indústria, Comércio, Ciência e Tecnologia, 1982. p. 01-39.
- MARTINS, M.C.; CÂMARA, G.M.S.; PEIXOTO, C.P.; MARCHIORI, L.F.S.; LEONARDO, V.; MATTIAZZI, P. Épocas de semeadura, densidade de plantas e desempenho vegetativo de cultivares de soja. Scientia Agrícola, v.56, n.4, p. 851-858, 1999.
- MIRANDA, M.A.C.; MASCARENHAS, H.A.A.; TURATTI, J.M.; RAMIRO, Z.A. Programa integrado de pesquisa de soja. São Paulo: Secretaria da Agricultura e Abastecimento/Coordenadoria de Pesquisa Agropecuária, 1986. 17p.
- MOTTA, I.S.; BRACCINI, A.L.; SCAPIM, C.A.; INOUE, M.H.; ÁVILA, M.R.; BRACCINI, M.C.L. Época de semeadura em cinco cultivares de soja. II. Efeito na qualidade fisiológica das sementes. Acta Scientiarum, v.24, n.5, p.1281-1286, 2002.
- NAKAGAWA, J.; MACHADO, J.R.; ROSOLEM, C.A. Efeito da densidade de plantas e da época de semeadura na produção e qualidade de sementes de soja. Revista Brasileira de Sementes, v.8, n.3, p.99-112, 1986.
- NAKAGAWA, J.; ROSOLEM, C.A.; MACHADO, J.R. Épocas de semeadura da soja. I. Efeitos na produção de grãos e nos componentes da produção. Pesquisa Agropecuária Brasileira, v.18, n.11, p.1187-1198, 1983.
- NAKAGAWA, J.; ROSOLEM, C.A.; MACHADO, J.R. Desempenho de sementes de soja originárias de culturas estabelecidas em diferentes épocas. Revista Brasileira de Sementes, v.6, n.3, p.61-76, 1984.
- NELSON, R.L.; BERNARD, R.L. Production and performance of hybrid soybeans. Crop Science, v. 24, p.549-553, 1984.
- OLIVEIRA, A.; SADER, R.; KRZYZANOWSKI, F.C. Danos mecânicos ocorridos no beneficiamento de sementes de soja e suas relação com a qualidade fisiológica. Revista Brasileira de Sementes, v. 21, n. 1, p.59-66, 1999.
- PAOLINELLI, G. de P.; TANAKA, M.A. de S.; REZENDE, A.M. de. Influência da época de semeadura sobre a qualidade fisiológica e sanitária de sementes de soja. Revista Brasileira de Sementes, v.6, n.1, p.39-50, 1984.
- PASCHAL II, E.H. & ELLIS, M.A. Variation in seed quality characteristics on tropically grown soybeans. Crop Science, v.18, n.3, p.837-40. 1978.
- PEIXOTO, C.P.; CÂMARA, G.M.S.; MARTINS, M.C.; MARCHIORI, L.F.S.; GUERZONI, R.A.; MATTIAZZI, P. Época de semeadura e densidade de plantas de soja: I. Componentes da produção e rendimento de grãos. Scientia Agrícola, v.57, n.1, p.89-96, 2000.

- PEREIRA, L.A.G.; COSTA, N.P.; QUEIROZ, E.F.; NEUMAIER, N.; TORRES, E. Efeito da época de semeadura sobre a qualidade de sementes de soja. *Revista Brasileira de Sementes*, v.1, n.3, p.77-89, 1979.
- PEREIRA, E.B.C.; PEREIRA, A.V.; FRAGA, A.C. Qualidade de sementes de cultivares precoces de soja produzidas em três épocas. *Pesquisa Agropecuária Brasileira*, v.35, n.8, p., 2000.
- POPINIGS, F. *Fisiologia da semente*. 2. ed. Brasília: AGIPLAN, 1985. 289p.
- FEHR, W.R.; CAVINESS, C.E.; GURMOOD, D.T.; PENNINGTON, J.S. Stage of development description for soybean, *Glycine max* (L.) Merrill. *Crop Science*, v.11, n.6, p.929-931, 1971.
- FRANÇA NETO, J.B.; HENNING, A.A. DIACOM: diagnóstico completo da qualidade da semente de soja. Londrina: EMBRAPA Soja, 1992. 21p. (Circular Técnica, 10).
- FRANÇA NETO, J.B.; HENNING, A.A. Qualidade fisiológica e sanitária de sementes de soja. Londrina: EMBRAPA Soja, 1984. 39p. (Circular Técnica, 9).
- ROBERTS, E.H. Loss of viability and crop yields. In: ROBERTS, E.H. (Ed.). *Viability of seeds*. London: Chapman and Hall, 1974. p.307-320.
- SANTOS, T. L. Soja. In: CASTRO, P. R. C.; KLUGE, R. A.; SESTARI, I. *Manual de fisiologia vegetal: fisiologia dos cultivos*. Piracicaba: Agronômica Ceres, 2008. p. 157-175.
- SEDIYAMA, T.; CARDOSO, A.A.; VIEIRA, C.; ANDRADE, D. Taxa de hibridação natural em soja, em Viçosa e em Capinópolis, Minas Gerais. *Revista Ceres*, v.2, p.329-331, 1970.
- SEDIYAMA, C.S.; VIEIRA, C.; SEDIYAMA, T.; CARDOSO, A.A.; ESTEVÃO, H.H. Influência do retardamento da colheita sobre a deiscência das vagens e sobre a qualidade e poder germinativo das sementes de soja. *Experientiae*, v.14, n.5, p.117-141, 1972.
- TEKRONY, D.M. Effect of date of haverstmataturity on soybean seed quality and *Phomopsis* sp. seed infection. *Crop Science*, v.24, n.1, p.189-193, 1984.
- TEKRONY, D.M.; EGLY, D.B.; PHILLIPS, A.D. Effects of field weathering on the viability and on vigor of soybean seed. *Agronomy Journal*, v.72, n.5, p.749-753, 1980.
- TRAGNAGO, J.L.; BONETTI, L.P. Diferentes épocas de semeadura no rendimento e outras características de alguns cultivares de soja no Rio Grande do Sul. In: SEMINÁRIO NACIONAL DE PESQUISA DE SOJA, 3., 1984, Campinas. *Anais...* Londrina: EMBRAPA/CNPSo, 1984. p.57-69.
- VAL, W.M.C.; GAUDENCIO, C.A. & GARCIA, A. Ensaio sobre época de plantio. In: Resultados da pesquisa de soja, 1984/85. Londrina: EMBRAPA-CNPSo, 1985. p.393-396.
- VERNETTI, F.J.; BONATTO, E.R.; TERASAWA, F.; GASTAL, M.F. Observações sobre a taxa de cruzamentos naturais em soja, em Pelotas e Sertão, RS e Ponta Grossa, PR. *Ciência e Cultura*, v.1, p.36-41, 1972.
- RAY, J.D.; KILEN, T.C.; ABEL, C.A.; PARIS, R.L. Soybean natural cross-pollination rates under field conditions. *Environmental Biosafety Research*, v.2, p.133-138, 2003.

YORINORI, J.T. Doenças da soja no Brasil. In: Fundação Cargill. Soja no Brasil Central. Campinas : Fundação Cargill, 1986. p.301-363

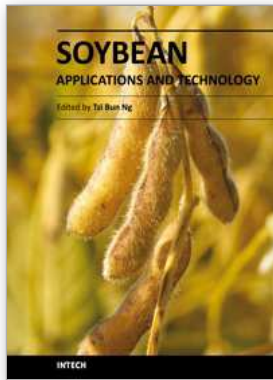

Soybean - Applications and Technology

Edited by Prof. Tzi-Bun Ng

ISBN 978-953-307-207-4

Hard cover, 402 pages

Publisher InTech

Published online 26, April, 2011

Published in print edition April, 2011

Soybean is an agricultural crop of tremendous economic importance. Soybean and food items derived from it form dietary components of numerous people, especially those living in the Orient. The health benefits of soybean have attracted the attention of nutritionists as well as common people.

How to reference

In order to correctly reference this scholarly work, feel free to copy and paste the following:

Marizangela Rizzatti Ávila, Alessandro de Lucca e Braccini, Leandro Paiola Albrecht and Carlos Alberto Scapim (2011). Soybean Seeds Produced in Out Season in West of Paraná State – Brazil, Soybean - Applications and Technology, Prof. Tzi-Bun Ng (Ed.), ISBN: 978-953-307-207-4, InTech, Available from: <http://www.intechopen.com/books/soybean-applications-and-technology/soybean-seeds-produced-in-out-season-in-west-of-paran-state-brazil>

INTECH

open science | open minds

InTech Europe

University Campus STeP Ri
Slavka Krautzeka 83/A
51000 Rijeka, Croatia
Phone: +385 (51) 770 447
Fax: +385 (51) 686 166
www.intechopen.com

InTech China

Unit 405, Office Block, Hotel Equatorial Shanghai
No.65, Yan An Road (West), Shanghai, 200040, China
中国上海市延安西路65号上海国际贵都大饭店办公楼405单元
Phone: +86-21-62489820
Fax: +86-21-62489821

© 2011 The Author(s). Licensee IntechOpen. This chapter is distributed under the terms of the [Creative Commons Attribution-NonCommercial-ShareAlike-3.0 License](#), which permits use, distribution and reproduction for non-commercial purposes, provided the original is properly cited and derivative works building on this content are distributed under the same license.

The Alternatives to Soybeans for Animal Feed in the Tropics

Archimède H¹, Régnier C¹, Marie-Magdeleine Chevry C¹,
Gourdine JL¹, Rodriguez L² and Gonzalez E³

¹INRA-UE143, *Prise d'Eau*, 97170 Petit-Bourg,

²*Finca Ecológica TOSOLY, AA#48 Socorro, Santander Sur,*

³UMR-INRA CIRAD SELMET, *2 place Viala, 34060 Montpellier cedex 1,*

¹*Guadeloupe French West Indies*

²*Colombia*

³*France*

1. Introduction

There are many alternatives to soya for animal feed in the tropics (e.g. meals coming from local protein-rich resources such as beans, peas, aquatic plants or leguminous foliage). The study and evaluation of such alternatives must be based on their amino acid availability and profile, using the approach of investigating non-ruminant species. For this criterion, there is often a gap between the amino acid profiles of plant resources and the profile of amino acids truly available for the animal. In the short and medium term, new studies have to be performed to take into account the large diversity of rich protein resources in the tropics. Overall, the alternatives are broader for herbivores than for other animal species, since the concentration of fibre and secondary compounds is a limiting factor that will discriminate their proposal of use among domestic animal species. Such evaluations must also take into account the farming system functions and productive purposes. The paradigm is changing and, compared to years ago, maximising animal performance is not the priority goal of the systemic approach. Currently, multiple animal responses to alternative diets should be taken into account for their optimisation. A criterion such as environmental impact is often decisive in the combination of global and local approaches.

2. The alternatives to soybeans for animal feeding and farming systems development in the tropics

Traditionally, the two main protein sources for livestock feed are protein crops (e.g. legumes) and animal by-products. Large amounts of animal by-products come from industry (mainly meat and fish meal). The technologies for manufacturing these products are strict in order to avoid health crises (e.g. BSE). Even if their use is limited to certain animal species, in some regions (like the European Union) their use is currently legally forbidden. The safety assessment of animal protein for animal feed can also be performed directly at the farm level. As in some Asian experiences (e.g. integrated farming systems in

Vietnam), some fish species are included into the cycle with a multi-species breeding approach. Other experiences include, for example, small-scale worm production for poultry nutrition. Until now, this kind of technology has mainly been associated with small farms. Some foliage, seeds and fruits from protein-rich plants are excellent sources of protein. The high efficiency of photosynthesis in the tropics is an asset. In addition, there is a great diversity of such plants rich in proteins which are potentially utilisable by animals. This biodiversity is in contradiction with the low number of resources actually used.

There is also a great potential to produce high yields of protein on farms with the inclusion of tropical species of forage trees and shrubs and aquatic plants in farming scenarios. The protein yields of such crops are sometimes higher than that of soya, as illustrated by Figure 1. However when one takes into account the digestibility of the biomass produced, soybeans retains high productivity.

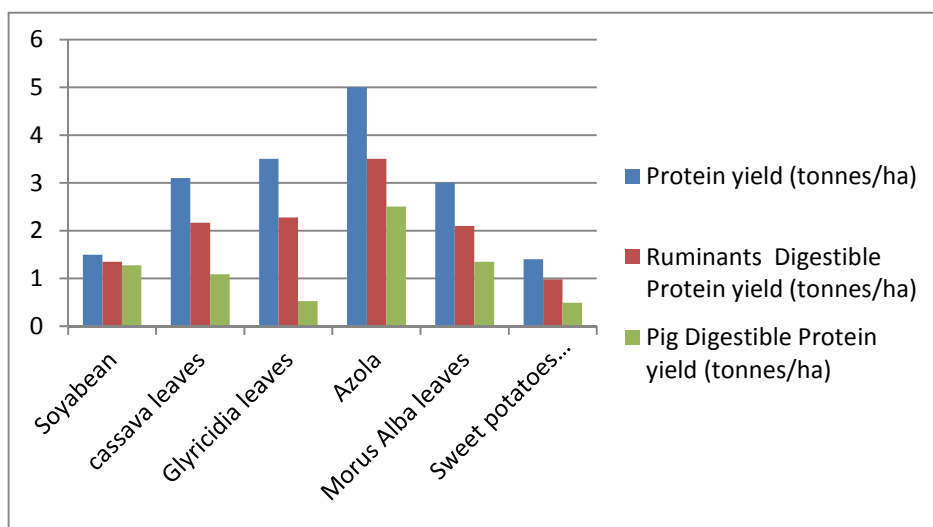

Fig. 1. Comparative protein yields in some typical crops from grown tropical latitudes.

The interest of plants as soybean alternative resources are very variable in the function of the target animal species considered because of the features of their digestive physiologies. The ability of certain animal species (i.e. ruminants) to digest fibre and synthesise some essential amino acids because of the presence of a large microbial population in the digestive tract gives them a clear advantage. Consequently, differences have to be made between herbivores (ruminants, horses, rabbits) and other animal species (i.e. non-ruminants or monogastrics like pigs or poultry). Globally, herbivores are able to valorise all plant fractions (foliage, seeds and fruits). Non-herbivores will be able to valorise mainly seeds, fruits and low fibre content foliage. Moreover, with the non-herbivores, the valorisation of foliage is better with low total fibre diets like molasses, sugar cane juice...

Soybean is widely used in conventional intensive animal feeding systems because of its known high protein content (38-42%) and good amino acid balance and digestibility (Baker, and Stein, 2009; Cervantes-Pahm *et al.*, 2008; Hartwig, *et al.*, 1997; Johnson, 2008; Opapeju *et al.*, 2006). Actually, there is a consensus on the criterion that the amino acid content, balance

and ileal digestibility of the abovementioned plant resources are the major criteria at the time of selecting the best alternatives. Unfortunately, these indications remain scarce for many alternatives to soya. Conventional concentrates based on cereals and soybean meals are generally imbalanced, in particular with regard to methionine, cysteine and threonine (Ogle, 2006). Most green forages are reasonably high in protein and contain concentrations of the essential amino acids that are close to matching the pig's requirements (Ogle, 2006). This means that if they are combined with an energy source that is extremely low in protein and fibre, such as sugarcane juice, molasses, sugar palm juice or cassava root meal, then the essential amino acid content of the overall diet will still be balanced and the protein content can be reduced by up to 30-35 % (Ogle, 2006).

Anti-nutritional factors could penalise choosing some foliage species. Many of the green forages in the tropics that are potentially valuable sources of protein contain anti-nutritional factors that can depress animal performance, such as cyanogenic glycosides, trypsin inhibitors, mimosine, goitrogens, oxalic acid, tannins and saponins. However, many of these can be inactivated to a greater or lesser extent by various processing methods, such as heat treatment, sun-drying or ensiling (Ogle, 2006).

3. Industrial oil seed by-product resources

Feed cakes, as by-products of the oil industry, comes from various seeds rich in oil and are widely used as animal feed (Table 1). Feed cakes are thus mainly used as a source of protein. The protein content and their amino acid profiles vary with the botanical origin of the seeds. They may also contain varying amounts of oil depending on the technology employed to perform oil extraction. They are also more or less rich in fibre in accordance, once more, with the botanical origin of the seed, or whether the seed has been peeled or not. Some seeds, depending on the variety, can contain large quantities of more anti-nutritional substances that can be eliminated by technological treatments. The amount of fibre and its digestibility affect the energy value of meals. Cakes richer in fibre are normally given to ruminants while the less fibre-rich by-products can be used by all animal species. Improper storage of the meal may cause the development of some toxic fungi (e.g., aflatoxin) that could put livestock health at risk.

4. Seed resources

Several reports concerning the interest in seeds as feed have been made: Bhat and Karim 2009; Mekbungwan, 2007 and Ekanayake et al. 2000. In temperate and tropical areas, the search for alternative protein sources has led to an increasing interest in the use of grain legumes. These legumes supply protein and are nitrogen-fixation crops in rotation or mixed crops within farms. One limit of grain legume use of in animal nutrition is the high concentration of secondary plant metabolites (protease inhibitors, alkaloids, lectins, pyrimidine, glycosides, saponins) found in some species. These metabolites, in some concentrations, can induce feed refusals (tannins, alkaloids), reduced nutrient digestibility (tannins, protease inhibitors, lectins) or even toxic effects (alkaloids) (Jezierny, 2010). Generally, secondary metabolites are more abundant in wild species compared with cultivated species.

In the tropics, some legumes seeds are food and feed and consequently competition potentially exists between humans and animals. Table 2 lists some tropical grain legumes.

| | Soybeans cake | Palm cake expeler | Cotton Cake | Cophra expeler | Cacao | Peanut Cake |
|-----------------------------|------------------|-------------------------|----------------|-------------------|-------|----------------|
| Component (g/ 100 g DM) | | | | | | |
| NDF | 12.2 | 65.8 | 31.8 | 49.7 | 37.6 | 20.1 |
| ADF | 7.3 | 40.4 | 22.2 | 26.1 | 28 | 14 |
| ADL | 0.7 | 12.1 | 6.8 | 6.1 | 14.5 | 4.6 |
| MAT | 45.3 | 14.8 | 36.3 | 20.5 | 25.2 | 49.2 |
| | | | | | | |
| Lysine | 6.1 | 2.7 | 4 | 2.6 | 4.3 | 3.3 |
| Threonine | 3.9 | 3 | 3.2 | 3 | 3.3 | 2.7 |
| Methionine | 1.4 | 1.8 | 1.5 | 1.4 | 0.9 | 1 |
| Cysteine | 1.5 | 1.1 | 1.7 | 1.3 | 1.1 | 0.9 |
| Methionine + Cysteine | 2.9 | 2.9 | 3.1 | 2.7 | 2 | 1.9 |
| Tryptophan | 1.4 | 0.7 | 1.3 | 1.3 | 1.1 | 1.2 |
| Isoleucine | 4.6 | 3.5 | 3.1 | 3 | 3.5 | 3.3 |
| Valine | 4.8 | 5 | 4.4 | 4.7 | 3.8 | 3.9 |
| Leucine | 7.4 | 6 | 5.6 | 5.8 | 6.2 | 6.2 |
| Phenylalanine | 5 | 3.9 | 5.1 | 4.1 | 4.2 | 4.7 |
| Tyrosine | 3.3 | 2.1 | 2.7 | 2 | 2.7 | 3.7 |
| Phenylalanine + Tyrosine | 8.4 | 5.9 | 7.8 | 6.1 | 6.9 | 8.4 |
| Histidine | 2.7 | 1.8 | 2.9 | 1.9 | 1.6 | 2.3 |
| Arginine | 7.4 | 11.2 | 10.6 | 10.6 | 5 | 11.5 |
| Alanine | 4.4 | 3.9 | 4.2 | 3.9 | 4 | 4 |
| Aspartic acid | 11.3 | 7.8 | 9.1 | 7.5 | 8.6 | 11.3 |
| Glutamic Acid | 17.8 | 18.1 | 18.6 | 17 | 15 | 18.8 |
| Glycine | 4.2 | 4.3 | 4 | 4.1 | 3.2 | 5.6 |
| Serine | 5 | 4.2 | 4.3 | 4.3 | 4 | 4.7 |
| Proline | 5.9 | 2.9 | 3.4 | 3.4 | 3.2 | 3.8 |

Table 1. Chemical composition of some cakes used in livestock diets (INRA 2004)

| | <i>Vigna Unguiculata</i> (1) | <i>Canavalia Ensiformis</i> (2) | <i>Sesbania Spp</i> (3) | <i>Cajanus Cajan</i> (4) |
|-------------------------|------------------------------|---------------------------------|-------------------------|--------------------------|
| Component (g/ 100 g DM) | | | | |
| NDF | 5.1-5.8 | 7.8.-10.4 | 10.9-15.8 | 6 |
| MAT | 21.5-26.4 | 24.9-35 | 33.1-32.3 | 25 |
| Lysine | 7.1-16.7 | 4.63-5.6 | 3.86-4.55 | 7.2 |
| Threonine | 3.7-8.6 | 3.26-4.24 | 2.08-2.45 | 3.2 |
| Methionine | 1.5-3.2 | 1.05-3.8 | 0.96-1.03 | 1 |
| Cysteine | | 0.59-1.13 | 0.66-0.75 | |
| Tryptophan | | 0.84-1.28 | 1.28-1.63 | 0.8 |
| Isoleucine | 4.9-11.2 | 3.4-7.4 | 2.39-3.06 | 3.8 |
| Valine | 5.7-12.7 | 3.09 | 2.52-3.00 | 4.3 |
| Leucine | 8.3-19.0 | 5.85-7.64 | 4.32-5.36 | 7 |
| Phenylalanine | 5.8-14.1 | 3.4-5.01 | 2.80-3.55 | 4.4 |
| Tyrosine | 5.4-5.9 | 2.58-3.54 | 2.14-2.75 | |
| Histidine | 3.4-7.9 | 2.80-4.23 | 7.41-12.53 | 3.9 |
| Arginine | 15.2-17.7 | 3.6-5.56 | 5.87-8.58 | |
| Alanine | | 3.38-3.98 | 2.58-3.00 | 5.9 |
| Aspartic acid | | 8.98-10.78 | 5.96-7.27 | |
| Glutamic acid | | 9.33-10.90 | 10.45-13.64 | |
| Glycine | | 3.99-4.56 | 3.63-4.76 | |
| Serine | | 3.61-5.37 | 3.14-3.94 | |
| Proline | | 3.06-4.97 | 2.61-3.39 | |

1)Tshovhote et al, 2003; Adbooye et al, 2007. 2) Siddhuraju and Becker, 2007; Ekanayake et al, 2000; Sridhar and Seena, 2006; Ekanayake et al, 1999.

3) Hossain and Becker, 2001.4) Mekbungwan, 2007

Table 2. Nutrients and amino acid composition of some legume seeds

5. Foliage resources

Several reviews have been made concerning the interest of foliage as feed: Wanapat, 2009; Preston, 2006 and Leng, 1997. A large diversity of foliage can be used as protein resources. As indicated for cakes, their chemical compositions vary with the botanical origin, level of protein, fibre and secondary compounds as well as the technologies used to discriminate the

foliage. The first reported works concerning high protein foliage concerned ruminants. Leng (1997) indicated that the role of fodder trees in ruminant diets can be seen as threefold:

- “as a N and mineral supplement to enhance fermentative digestion and microbial growth efficiency in the rumen of cattle on poor quality forage
- As a source of post-ruminal protein for digestion. In this role, the influence of secondary plant compounds in binding protein and making it insoluble is of particular importance
- As a total feed, supplying almost all the biomass and other nutrients needed to support high levels of animal production”.

A low level of tannin (less than 5% dry matter) can have a positive impact by protecting the protein against ruminal degradation and contributing to enhanced intestinal amino acid flow useful for the animal. Dried foliage improves ruminant growth compared with fresh material. This response might be related to a change in the decrease of protein solubility in the rumen and increasing the bypass protein content of dry leaves. Drying also reduces the tannin content of the leaves.

Patra et al (2008, 2009) conducted a meta-analysis on the effect of supplementation of forages with foliages for ruminant diets. The main conclusions are: 1) organic matter digestibility of rations increases, following a linear law. The laws of response to crude protein content of the forage and the total diet are quadratic with an optimum reached with 14-15% of foliage in the total diet, 2) The CP digestibility of the diet is affected by the percentage of foliage in the diet, the CP content and the amount of crude protein supplied by the foliage, the NDF content of foliages, 3) The maximum intake of organic matter and digestible protein are reached with respectively 37 and 42% of foliage in the diet. The optimum catalytic properties (rumen microbial digestion) is achieved with 16% of foliage in the diet, although due to the response on intake, 42% of foliage in the diet are needed to achieve optimum animal performance.

Preston (2006) did a review on the interest of foliage as pig feed. A large diversity of resources can be used. Foliage with a low level of fibre is the best feed and needs to be associated with low fibrous diets.

Recently, Regnier (2011) studying the intake and digestion of several foliages concluded that, due to their high fill unit and low digestibility, their contribution should not exceed 25% of the total dry matter intake in growing pigs to avoid penalising their growth. The non-protein nitrogen, and therefore not usable by pigs, contributes 25-30% of the total nitrogen content in the foliages. The digestibility of amino acids was varied from 15 to 45%. Leterme (2009, 2010) had similar conclusions but indicated that sows digested better these resources compared to growing pigs.

5.1 General considerations

Table 3 reports the chemical composition of several foliages. There is variation with contradictory values being reported by different authors.

Foliage has a relatively low level of crude fibre and a ratio of sulphur amino acids relative to lysine close to that in the “ideal protein” (Preston 2006). The wide differences found in many reports for amino acid levels in cassava and sweet potato leaves, for example, emphasises the need for a coordinated research effort in which common samples of the most useful protein-rich leaves are distributed for analysis to several laboratories where the necessary equipment and expertise are available (Preston 2006).

| | Ideal protein (1) | Soybean meal (2) | Water spinach (3) | Cassava leaves (4) | Sweet potato leaves (5) | Duckweed (7) | New cocoyam (6) | Mulberry (3) |
|---|-------------------------|------------------------|-------------------------|--------------------------|-------------------------------|-----------------|-----------------------|-----------------|
| g AA/kg N*6.25 | | | | | | | | |
| Lysine | | 63.2 | 42.7 | 56-65 | 39 | 43 | 46 | 50.6 |
| Methionine | | | 13.5 | 18-21 | 16.3 | 27.9 | 14.3 | 16.5 |
| Cysteine | | | 10.3 | 15-16 | 5.27 | 7.38 | 12.6 | 12.0 |
| Met+Cys | | 28.3 | 23.8 | 33-37 | 39 | 35.3 | 26.9 | 28.6 |
| Threonine | | 38.9 | 39.5 | 47 | 51 | 42 | 39.5 | 45.1 |
| As proportion of lysine = 100 | | | | | | | | |
| Lysine | 100 | 100 | 100 | 100 | 100 | 100 | 100 | 100 |
| Met+Cys | 59 | 44.8 | 56 | 53-57 | 55 | 82 | 58.5 | 56.4 |
| Threonine | 75 | 61.6 | 92 | 76 | 114 | 98 | 85.6 | 89.1 |
| Composition of fresh leaves, g/kg fresh matter | | | | | | | | |
| DM | | | 83 | 320 | 161 | 62 | 180 | 261 |
| Composition, g/kg DM | | | | | | | | |
| Crude protein | | 51.8 | 267 | 245 | 282 | 370 | 248 | 222 |
| Crude fibre | | 31 | 155 | 156 | 128 | 77 | 142 | 172 |
| Ash | | 62 | 142 | 84 | 109 | 16 | 133 | 126 |

(1)Wang and Fuller 1989; (2) Martin 1990 ; (3) Phiny et al 2003; Phiny 2006, personal communication; (4) Eggum 1970; (5) Woolfe 1992; (6)Rodríguez et al 2006; (7) Le Thi Men 2006

Table 3. Major essential AA in the “ideal protein”, soybean meal and leaves of selected protein-rich leaves (Preston 2006)

In the following, we concentrate the discussion on some potential tropical resources, which should be taken into account as alternatives to the use of soybean meal in animal nutrition.

5.2 Giant Taro (*Alocasia macrorrhiza*) and New cocoyam (*Xanthosoma sagittifolium*) leaves

Giant Taro is widely distributed in tropical latitudes. It has high protein (24% in DM) and low crude fibre (15% in DM) contents (Gohl, 1973). Nevertheless, many varieties have a pungent taste caused by oxalate crystals which also cause the mouth to itch (Gohl, 1973). In Cambodia, for example, farmers traditionally boil the leaves before feeding them to pigs as in the fresh state the leaves are not readily consumed (Preston 2006).

“New Cocoyam” is thought be native to South and Central America. It is highly palatable to pigs (Rodríguez et al. 2009). With growing pigs fed a low fibrous diet like sugarcane juice, a level of 50% of substitution of soybean meal protein with New cocoyam leaves did not affect growth as illustrated in Figure 2.

5.3 Sweet potato (*Ipomoea batatas*) foliage

The crude protein and crude fibre content of the foliage of sweet potato vary largely with the variety and the plant fraction (leaves or stem). Crude protein contents range from 26.5 to 32.5% and 10.4 to 14.1% in leaves and stems, respectively (Preston, 2006). Mean values of

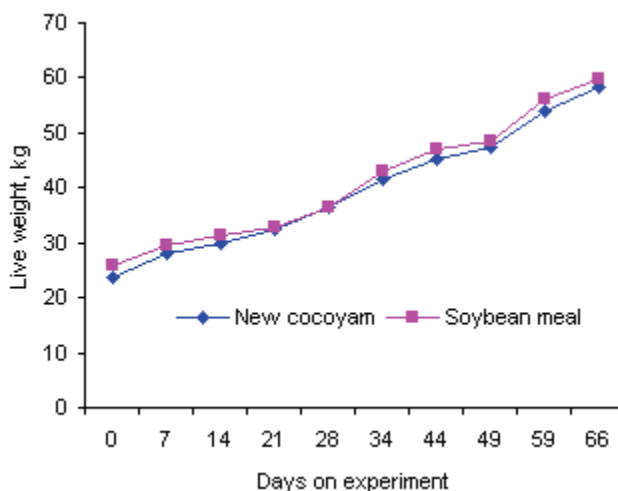

Fig. 2. Growth curves of pigs fed a basal diet of sugarcane juice supplemented with soybean meal or a 50:50 mixture (equal protein basis) of the leaves of "New Cocoyam" and soybean meal (Preston, 2006).

crude fibre are 11.1 and 20.7% for leaves and stems, respectively (Preston, 2006). The total essential amino acid content in the protein is higher than in soybean protein (Phuc et al, 2000 2001; Montagnac et al., 2009).

Van Ann et al. (2005) have compared in Vietnam four crossbred (*Large White* x *Mon Cai*) diets formulated with protein from fish meal, groundnut cake, ensiled sweet potato leaves and ensiled sweet potato leaves with lysine. They concluded that sweet potato leaves can replace fish meal and groundnut cake in traditional Vietnamese diets for growing pigs. Nguyen et al (2010) indicated that sweet potato vines replacing 70% of the CP from fish meal in diets and providing 35% of the total CP had no effect on the performance and carcass traits of *Large White* x *Mong*.

5.4 Mulberry (*Morus alba*) forage

An overview of the interest of mulberry as feed is available from Sánchez (2000, 2002). Mulberry agronomic productivity, palatability and nutritive value make it an important resource for improving and intensifying a large variety of livestock production practices. Mulberry foliage is used for ruminants and monogastric animals. The protein content is high (15 to 28% depending on the variety) in the leaves and young stems, with a good essential amino acid profile (Sánchez 2002). No anti-nutritional factors or toxic compounds have been reported. Mineral content is high. The leaves are used as supplements replacing concentrates for dairy cattle, as a main feed for goats, sheep and rabbits and as an ingredient in monogastric diets (Leterne, 2009).

5.5 Cassava (*Manihot esculenta*) leaves

Cassava leaves are rich in protein and the total essential amino acid content in the protein has been reported to be higher than in soybean protein (Phuc, 2000; Montagnac et al., 2009). However, the high HCN content of fresh cassava leaves limits its use. Processing this forage

with technologies like drying or ensiling can markedly reduce the HCN content (Borin et al., 2005). Nguyen et al. (2010) evaluated the effects of replacing 70% of the protein from fish meal by protein from ensiled or dry cassava leaves on the performance and carcass characters of growing F1 (*Large White* × *Mong Cai*) pigs in Central Vietnam. The results showed that final body weight, daily average weight gain (450 g/day) and the dry matter intake and feed conversion ratio (FCR) among experimental treatments were not significantly different. It was concluded that using ensiled or dry cassava leaves replacing 70% of the CP from fish meal in diets and providing 35% of the total CP had no effect on the performance and carcass traits of the *Large White* × *Mong Cai* pigs.

5.6 Duckweed (*Lemna* spp.)

Duckweed (*Lemna* spp.) are small floating aquatic plants found worldwide. They are monocotyledons of the botanical family *Lemnaceae* and form dense mats over large areas of the water surface. Duckweeds are free-floating and do not have stems or typical leaves.

Leng et al (1995) reported that, in sewage water in Australia, the protein content of duckweed increased from 20-25 to 35-40% in dry matter when N in the water increased from <5 to 15 mg/litre). In this same trial, the yields of duckweed dry matter were in the range of 10 to 30 tonnes/ha/year, equivalent to protein yields of duckweed of as high as 10 tonnes/ha/yr.

Anh and Preston 1997 compared the growth of ducks fed with cassava meal and sugar. The protein sources were soya meal or duckweed. It was reported that duckweed can be used as a non-conventional protein source to completely replace soya bean meal and could be the sole source of protein in diets for ducks. Nevertheless, the availability of protein in duckweed should be lower than that of soya bean. This result has been explained by the fibre contents of the products. There was more fibre in duckweed (10% dry matter) than in soya bean meal (about 5% fibre), so it is likely that the digestibility of the protein in duckweed is the factor limiting its utilisation.

Preston (2000) reported mean growth of 500 g/day against 400 g/day for pigs fed with fresh duckweed protein source versus rice by-products on farms in Central Vietnam.

6. Conclusions

In conclusion, within the vast tropical biodiversity, there are many plant resources to replace partially or completely soybeans in livestock diets. The possibilities of substitution of soybean by other resources are more important for herbivores in relation to non-herbivores. Resources alternative to soybean are used mainly on smallholder mixed farming involving livestock and crops. In the modern farming systems, livestock receive diets based on cereal and soybean as the main sources of energy and protein respectively. Further research needs to be performed to study the alternatives to soya.

7. References

- Baker, K. M., Stein H. H. 2009. Amino acid digestibility and concentration of digestible and metabolizable energy in soybean meal produced from conventional, high-protein, or low-oligosaccharide varieties of soybeans and fed to growing pigs. *Journal of Animal Science* 87, 2282–2290.

- Bhat, R., Karim, A.A., 2009. Exploring the nutritional potential of wild and underutilized legumes. *Comprehensive reviews in food Science and food safety* 8, 305-33.
- Borin, K., Lindberg, J. E., Ogle, R. B. 2005. Effect of variety and preservation method of cassava leaves on diet digestibility by indigenous and improved pigs *Journal of Animal Science* 80, 319-324.
- Cervantes-Pahm, S. K., Stein, H. H. 2008. Effect of dietary soybean oil and soybean protein concentration on the concentration of digestible amino acids in soybean products fed to growing pigs. *Journal of Animal Science* 86:1841-1849.
- Ekanayake, S., Jansz E.R., Nair, B. 2000. Literature review of an underutilized legume: *Canavalia gladiata* L. *Plant Foods for Human Nutrition* 55, 305-321.
- Ekanayake, S., Jansz, E.R., Nair, B. 1999. Proximate composition, mineral and amino acid content of mature *Canavalia gladiata* seeds. *Food Chemistry* 66, 115-119.
- Hartwig, E. E., Kuo T. M., Kenty M. M. 1997. Seed protein and its relationship to soluble sugars in soybean. *Crop Science* 37, 770-778.
- Hossain, M.A., Becker, K. 2001. Nutritive value and antinutritional factors in different varieties of *Sesbania* seeds and their morphological fractions. *Food Chemistry* 73 421-431.
- INRA, 2004. Tables de composition et de valeur nutritive des matières premières destinées aux animaux d'élevage Porcs, volailles, bovins, ovins, caprins, lapins, chevaux, poissons - Sauvart D., Perez J.-M., Tran G. coord., 2e édition revue et corrigée, ISBN 2-7380-1158-6 2004, 304 p. INRA Editions Versailles.
- Jezierny, D., Mosenthin, R., Bauer E. 2010. The use of grain legumes as a protein source in pig nutrition: A review. *Animal Feed Science and Technology* 157, 111-128.
- Johnson, L. A. 2008. Oil recovery from soybeans. Pages 331-375 in *Soybeans, Chemistry, Production, Processing, and Utilization*. L. A. Johnson, P. J. White, and R. Galloway, ed. AOCS Press, Urbana, IL.
- Leng, R A., Stambolie, J H., Bell, R. 1995. Duckweed-Potential high protein feed resource for domestic animal and fish. *Livestock Research for Rural Development*. Volume 7, Number 1.
- Leng, R A., 1997. Tree foliage in ruminant nutrition. *FAO Animal Production and Health Paper* 139.
- Mekbungwan, A. 2007. Application of tropical legumes for pig feed. *Animal Science Journal* 78, 342-350.
- Leterme, P., Botero, M., London, A. M., Bindelle, J., Buldgen A, 2009. Nutritive value of tropical tree leaf meals in adult sows. *Animal Science* 82, 175-182.
- Leterme, P., Londono, A.M., Ordonez, D C., Rosales, A., Estrada, F., Bindelle, J., Buldgen A. 2010. Nutritional value and intake of aquatic ferns (*Azolla filiculoides* Lam. and *Salvinia molesta* Mitchell.) in sows. *Animal Feed Science and Technology* 155, 55-64.
- Montagnac, A. J., Christopher, R. D., Tanumihardjo S. A. 2009. Nutritional value of cassava for use as a staple food and recent advances for improvement. *Compr Rev. Food Sci. Food Saf.* 8:186-194.
- Nguyen Duc Anh, Preston T R. 1997. Evaluation of protein quality in duckweed (*Lemna spp.*) using a duckling growth assay. *Livestock Research for Rural Development*. Volume 7, Number 1.

- Opapeju, F. O., Golian, A., Nyachoti, C. M., Campbell, L. D.. 2006. Amino acid digestibility in dry extruded-expelled soybean meal fed to pigs and poultry. *Journal of Animal Science* 84,1130-1137.
- Ogle R B 2006. Forages for pigs: nutritional, physiological and practical implications Workshop-seminar "Forages for Pigs and Rabbits" MEKARN-CelAgrid, Phnom Penh, Cambodia, 22-24 August, 2006. Retrieved December 19, 110, from <http://www.mekarn.org/proprf/ogle.htm>
- Patra, AK. 2008. A meta-analysis on effects of supplementing low-quality roughages with foliages from browses and tree fodders on intake and growth in sheep. *Livestock Science*.121, 239-249.
- Patra, AK. 2009. Effects of supplementing low-quality roughages with tree foliages on digestibility, nitrogen utilization and rumen characteristics in sheep: a meta-analysis. *Journal of Animal Physiology and Animal Nutrition* 94, 338-353.
- Phuc, B. H. N., Lindberg J. E. 2001. Ileal digestibility of amino acids in growing pigs given cassava root meal diets with inclusion of cassava leaves, leucaena leaves and groundnut foliage. *Animal Science* 72, 511-517.
- Phuc, B. H. N., Ogle, B., Lindberg, J. E.. 2000. Effect of replacing soybean protein with cassava leaf protein in cassava root meal based diets for growing pigs on digestibility and N retention. *Animal Feed Science and Technology* 83:223-235.
- Preston T R 2006. Forages as protein sources for pigs in the tropics. Workshop-seminar "Forages for Pigs and Rabbits" MEKARN-CelAgrid, Phnom Penh, Cambodia, 22-24 August, 2006. Retrieved December 19, 110, from <http://www.mekarn.org/proprf/preston.htm>.
- Ravindran, V., 1993. Cassava leaves as animal feed: Potential and limitations. *J. Sci. Food Agric.* 41:45-53.
- Régnier, C. 2011. Valorisation des ressources alimentaires tropicales (feuillages et tubercules) chez le porc. Thèse de doctorat, Université des Antilles et de la Guyane, 203 p.
- Rodríguez, L., Peniche, I., Preston T R., Peters, K. 2009: Nutritive value for pigs of New Cocoyam (*Xanthosoma sagittifolium*); digestibility and nitrogen balance with different proportions of fresh leaves and soybean meal in a basal diet of sugar cane juice. *Livestock Research for Rural Development*. Volume 21, Article #16. Retrieved December 20, 2010, from <http://www.lrrd.org/lrrd21/1/rodr21016.htm>
- Sanchez, MD., 2002. Mulberry for animal production. *FAO Animal Production and Health Paper* 147.
- Sánchez MD., 2000. Mulberry: an exceptional forage available almost worldwide!. *World Animal Review*. 93(1), FAO, Rome.
- Sridhar K.R., Seena S. 2006. Nutritional and antinutritional significance of four unconventional legumes of the genus *Canavalia* - A comparative study. *Food Chemistry* 99, 267-288.
- Siddhuraju, P., Becker, K. 2005. Nutritional and antinutritional composition, in vitro amino acid availability, starch digestibility and predicted glycemic index of differentially processed mucuna beans (*Mucuna pruriens* var. *utilis*): an under-utilised legume. *Food Chemistry* 91, 275-286.

- Tshovhote, N.J., Nesamvuni, A.E., Raphulu, T., Gous, R.M. 2003. The chemical composition, energy and amino acid digestibility of cowpeas used in poultry nutrition. *South African Journal of Animal Science* 33, 65-69.
- Van An, L., Hong, T. T. T., Ogle, B., Lindberg, J. E. 2005. Utilization of ensiled sweet potato (*Ipomoea batatas* (L.) Lam) leaves as a protein supplement in diets for growing pigs. *Tropical Animal Health Production* 37, 77-88.
- Wanapat, M. 2009. Potential uses of local feed resources for ruminants. *Tropical Animal Health Production* 41, 1035-1049.

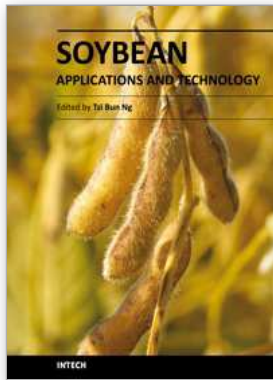

Soybean - Applications and Technology

Edited by Prof. Tzi-Bun Ng

ISBN 978-953-307-207-4

Hard cover, 402 pages

Publisher InTech

Published online 03, February, 2011

Published in print edition February, 2011

Soybean is an agricultural crop of tremendous economic importance. Soybean and food items derived from it form dietary components of numerous people, especially those living in the Orient. The health benefits of soybean have attracted the attention of nutritionists as well as common people.

How to reference

In order to correctly reference this scholarly work, feel free to copy and paste the following:

Archimède H, Régnier C, Marie-Magdeleine Chevy C, Gourdine JL, Rodriguez L and Gonzalez E (2011). The Alternatives to Soybeans for Animal Feed in the Tropics, Soybean - Applications and Technology, Prof. Tzi-Bun Ng (Ed.), ISBN: 978-953-307-207-4, InTech, Available from: <http://www.intechopen.com/books/soybean-applications-and-technology/the-alternatives-to-soybeans-for-animal-feed-in-the-tropics>

INTECH

open science | open minds

InTech Europe

University Campus STeP Ri
Slavka Krautzeka 83/A
51000 Rijeka, Croatia
Phone: +385 (51) 770 447
Fax: +385 (51) 686 166
www.intechopen.com

InTech China

Unit 405, Office Block, Hotel Equatorial Shanghai
No.65, Yan An Road (West), Shanghai, 200040, China
中国上海市延安西路65号上海国际贵都大饭店办公楼405单元
Phone: +86-21-62489820
Fax: +86-21-62489821

© 2011 The Author(s). Licensee IntechOpen. This chapter is distributed under the terms of the [Creative Commons Attribution-NonCommercial-ShareAlike-3.0 License](#), which permits use, distribution and reproduction for non-commercial purposes, provided the original is properly cited and derivative works building on this content are distributed under the same license.

Application of Nondestructive Measurement to Improve Soybean Quality by Near Infrared Reflectance Spectroscopy

Jeong-Dong Lee¹, J. Grover Shannon² and Myoung-Gun Choung³

¹*Division of Plant Biosciences, Kyungpook National University, Daegu 702-701*

²*Division of Plant Sciences, University of Missouri-Delta Center, Portageville, MO 63873*

³*Dept. of Herbal Medicine Resource, Kangwon National University, Samcheok 245-722*

^{1,3}*Republic of Korea*

²*USA*

1. Introduction

Soybean [*Glycine max* (L.) Merr.] is the world's primary protein and oil source for human and animals. Soybean seeds average 40% protein, 35% carbohydrate, 20% oil, and 5% ash. Soybean is not only an essential and dominant source of nutrition for humans and animals but it also has numerous other uses and is the leading source for biodiesel. Soybean represented 56% of the world's vegetable oil seed production, and soybean oil was second only to palm (Arecaceae: *Elaeis*) oil in consumption (<http://www.soystats.com>). Recent studies indicate that consumption of soybean reduces cancer, blood serum cholesterol, osteoporosis and heart disease (Birt et al., 2004). Also, soybeans are a good source of minerals, vitamins, folic acid, and isoflavones which are credited with slowing the development of these diseases (Wilson, 2004). Thus, the demand for edible soybean products has increased dramatically. Also, the desire for more meat in diets among the world's population has increased, consequently the demand for soybean protein for livestock and poultry feed has increased. In addition to feed and food, soybean has numerous industrial applications such as building materials, plastics, printing inks, paints, hydraulic fluids, cosmetics, pharmaceuticals and soy-diesel fuel that burns cleaner and pollutes less than petroleum derived fuels.

The increased importance of soybeans as a world crop has led to a huge expansion in world soybean production (<http://www.soystats.com>). In the last twenty years, world soybean production has increased steadily from 70 million tons in 1984 to 220 million tons in 2008. About 80% of the world supply was produced in North and South America. The United States, Brazil and Argentina were the major producers and exporters of soybean. In 2008, among these countries, the United States was the leading soybean producer at 73 million tons or about 33% of the total world production. At the same time Brazil and Argentina produced about 61 (28%) and 46 (21%) million tons, respectively (<http://www.soystats.com>). Although soybean is native to China, China produced 14 million tons (6% of the total) and India produced about 9 million tons (4% of the total). The remaining 5% was produced in countries of Asia and Europe. In 2008 total oilseed

production was 391 million tons of which 56% (220 million tons) was from soybean making it the world's number one oil seed crop followed by rapeseed and cotton seed at 12% each.

Improving soybeans for various uses is a goal of scientists. Soybeans high in protein quantity and quality for soy-foods and animal feeds; high oil content with altered fatty acid profile for a healthier and more functional oil for food applications and biodiesel; high isoflavone content for lower cancer risk and other human health benefits; low phytic acid content seed for improved digestible phosphorus in animal feeds to reduce phosphorus pollution in the environment; high sucrose content for vegetable soybean; small seed for natto and soybean sprouts; big seed for tofu and soy paste, lipoxygenase free seed for soymilk; colored seed coat or cotyledon for cooking with rice; and other altered minor seed components will lead to greater market demand for soybeans.

Improving seed quality and agronomic traits in soybean has been and continues to be a goal of soybean research programs including soybean breeding. Measurement of soybean seed for various seed components is often difficult and expensive. Complicated, time consuming techniques to determine seed components is a limiting factor in improvement programs because the number of genotypes which can be evaluated is limited. Soybean scientists have used wet chemistry methods to measure various seed components in soybean or soybean products. Wet chemistry is the most accurate way to measure the levels of seed components. However, this method requiring destruction of soybean seed or products, is time consuming, and is too slow and labor intensive for soybean improvement programs when many samples have to be screened. Easier and effective determination of soybean genotypes such as using Near Infrared reflectance (NIR) for measuring the promising characteristics mentioned above would greatly enhance progress in improving soybean for important seed components.

NIR was discovered by Friedrich Wilhelm Herschel in 1800 (Davies, 2000) and covers the range of the electromagnetic spectrum from 780 to 2500nm. In NIR spectroscopy, the product (such as soybean seed) is irradiated with NIR, and the reflected or transmitted radiation is measured. While the radiation penetrates the product, its spectral characteristics change through wavelength dependent scattering and absorption processes. This change depends on the chemical composition of the product, as well as on its light scattering properties which are related to the microstructure (Fig. 1).

Advanced multivariate statistical techniques, such as partial least squares regression are then applied to extract the required information from the usually convoluted spectra. The most attractive merit using NIR spectroscopy is to determine chemical composition of samples without any destruction. Since its discovery NIR spectroscopy has been applied to determine various chemical components in seed, plants, and food from many crops.

In soybean, NIR spectroscopy has been used to determine chemical composition of seed, and of other products and for evaluating soybean genotypes for various seed components. The increasing the importance of NIR spectroscopy in soybean seed composition improvement programs; the principles of NIR spectroscopy; applications for soybean seed composition improvement; and limitations of NIR technology and future research required to improve soybean seed components using NIR will be discussed in this chapter.

2. The general principles and procedures for NIR analysis in soybean

2.1 Determine soybean seed compositions that are needed by NIR application

As mentioned earlier, soybean has many useful chemical components such as protein, oil, fatty acids in soybean oil, isoflavones, sucrose, and carotenoids. If the target component has

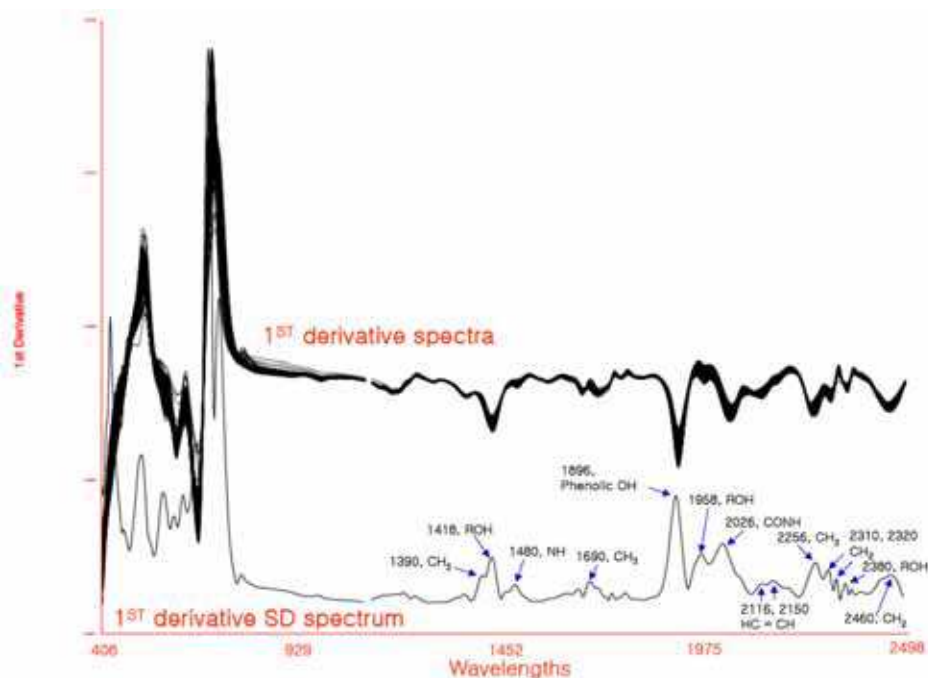

Fig. 1. First derivate (1,4,4,1) spectra and standard deviation (SD) spectrum of soybean samples (unpublished data)

A wide range of variation in soybean populations, it is relatively easy to make reliable calibration curves to estimate the amount of a target component by NIR spectroscopy. There is a wide range of genetic variation for chemical concentration among accessions of the soybean germplasm (Table 1). Two major seed components, protein and oil show a wide range of variation. However some minor seed components such as cysteine, methionine, tryptophan, and stearic acid have a relatively narrow range of variation which can limit use of NIR for measuring these traits among soybean genotypes. Good calibration curves are available for NIR spectroscopy to estimate concentration of soybean components such as protein, oil, sucrose etc. The details for measuring seed components using NIR are presented below.

2.2 Spectra collection and pretreatment

An NIR spectrophotometer consists of a light source (usually a tungsten halogen light bulb), sample presentation accessory, monochromator, detector, and optical components, such as lenses, collimators, beam splitters, integrating spheres and optical fibers. Spectrophotometers are conveniently classified according to the type of monochromator (Nicolai et al., 2007). In a filter instrument, the monochromator is a wheel holding a number of absorption or interference filters. Its spectral resolution is limited. In a scanning monochromator instrument a grating or a prism is used to separate the individual frequencies of the radiation either entering or leaving the sample (Fig. 2).

The wavelength separator rotates so that the radiation of the individual wavelengths subsequently reaches the detector. Four more spectrometer types, Fourier transform (FT)

spectrophotometers, Photodiode array (PDA) spectrophotometers, Acoustic optic tunable filter (AOTF) instruments, and Liquid crystal tunable filter (LCTF) instruments are available for NIR analysis (Nicolai et al., 2007). In soybean, many NIR studies for determination of soybean components and other traits have been conducted using scanning monochromator spectrophotometer with reflectance acquisition mode (Table 5).

| Seed compositions | Number of accessions | Range | Source |
|-------------------|----------------------|--------------------|-------------------------|
| Protein | 5530 | 32.5-55.9% | GRIN |
| Agrinine | 5530 | 5.0-9.8% | GRIN |
| Cysteine | 5530 | 1.10-2.67% | GRIN |
| Isoleucine | 5530 | 2.30-6.40% | GRIN |
| Leucine | 5530 | 6.50-9.20% | GRIN |
| Lysine | 5530 | 2.50-7.70% | GRIN |
| Methionine | 5530 | 1.50-2.80% | GRIN |
| Threonine | 5530 | 2.80-4.30% | GRIN |
| Tryptophan | 5530 | 0.90-1.70% | GRIN |
| Valine | 5530 | 4.10-6.90% | GRIN |
| Oil | 5530 | 8.9-25.6% | GRIN |
| Palmitic acid | 5530 | 4.1-14.0% | GRIN |
| Stearic acid | 5530 | 3.0-5.5% | GRIN |
| Oleic acid | 5530 | 17.1-37.7% | GRIN |
| Linoleic acid | 5530 | 46.0-58.7% | GRIN |
| Linolenic acid | 5530 | 3.6-12.4% | GRIN |
| Sucrose | 5483 | 0.0-11.3% | GRIN |
| Stachyose | 5522 | 0.8-8.1% | GRIN |
| Lutein | 490 | 1.6-14.8ug/g | (Kanamaru et al. 2006). |
| Total isoflavone | 1296 | 278.4 -2,736.9µg/g | (Han et al., 2008). |
| Daidzein | 1296 | 48.8 - 1,709.6µg/g | (Han et al., 2008). |
| Glycitein | 1296 | 0.98 - 892.3µg/g | (Han et al., 2008). |
| Genistein | 1296 | 79.8 - 1242.3µg/g | (Han et al., 2008). |

USDA, ARS, National Genetic Resources Program. *Germplasm Resources Information Network - (GRIN)*. [Online Database] National Germplasm Resources Laboratory, Beltsville, Maryland. Available: <http://www.ars-grin.gov/cgi-bin/npgs/html/eval.pl?494186> (30 August 2010)

Table 1. Wide range of genetic variation for some seed components in soybean seed.

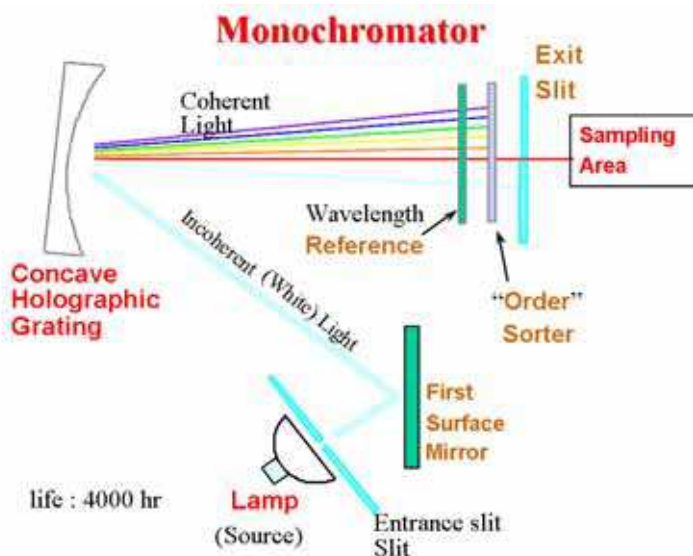

Fig. 2. General schematic of monochromator.

2.2.1 Measurement setup

Three different measurement setups for obtaining near infrared spectra are shown in Fig. 3. In the reflectance, the light source, and detector are mounted at under a specific angle to avoid specular reflection. In the transmittance mode the light source is positioned opposite to the detector, while in the interactance mode the light source and detector are positioned parallel to each other in such a way that light due to specular reflection cannot directly enter the detector.

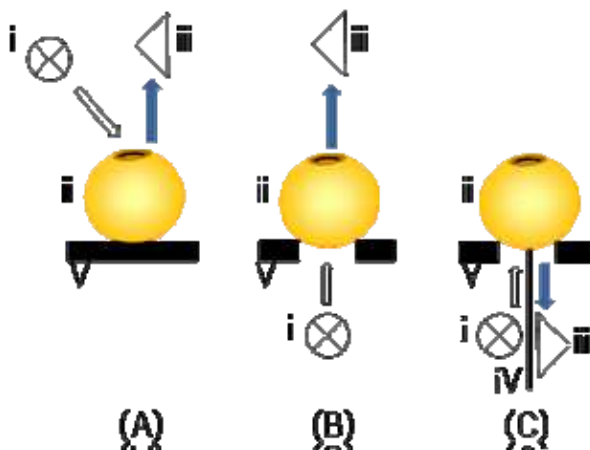

Fig. 3. Setup for the acquisition of (A) reflectance, (B) transmittance, and (C) interactance spectra, with (i) the light source, (ii) soybean, (iii) monochromator/detector, (iv) light barrier, and (v) support (modified from Nicolai et al., 2007).

2.2.2 Spectra collection

The general procedures from collection spectra from a soybean sample to validation of results for a developed equation was described (Choung et al., 2001b; Kim et al., 2007; Choung, 2010) with minor modifications. The NIR spectroscopic analysis was performed using a NIRSystem model 6500 near-infrared scanning monochromator (Foss NIRSystems Inc., Silver Spring, MD) in the reflectance mode. Intact seed samples, single seed, bulk seeds and flour, were placed in a standard ring cup and scanned (Fig. 4).



Fig. 4. General shape of soybeans, single seed (A), bulk seeds in cup (B), and soybean flour (C) for spectra collection.

Reflectance energy readings were referenced to corresponding readings from an internal ceramic disk (Fig. 5). Each spectrum was recorded from each sample, and the average of at least 16 successive scans was recorded. As a control, 16 scans over the standard ceramic disk were made before and after the samples were scanned.

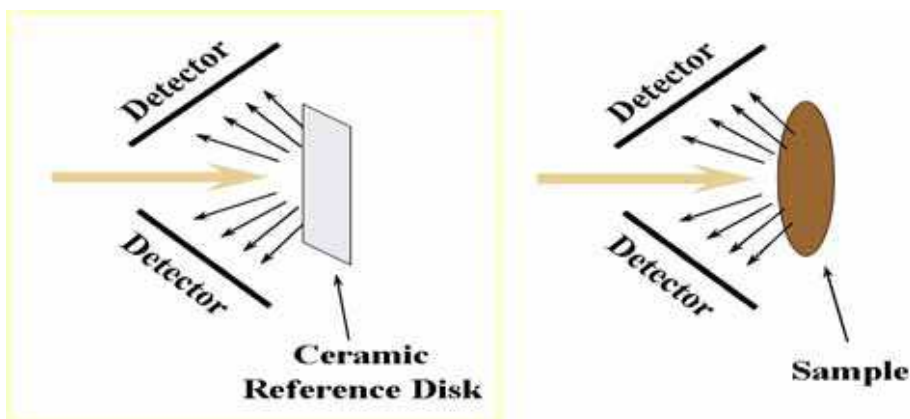

Fig. 5. Schematics for reflectance reading by the reference disk (left) and the sample (right)

Typical NIR reflectance spectra of single seed, bulk seed and flour of soybean are shown Fig. 6. All spectral data were recorded as the logarithm of the reciprocal of reflectance ($\log 1/R$) in the wavelength range from 400 to 2500 nm at 2 nm intervals to give a total of 1050 data points per sample. Absorption of radiation in the region of 400-2500 nm, the visible plus near-infrared region, was used to develop calibration equations related to sample properties. The scanning procedure could be completed in 1.5 min per sample, once the

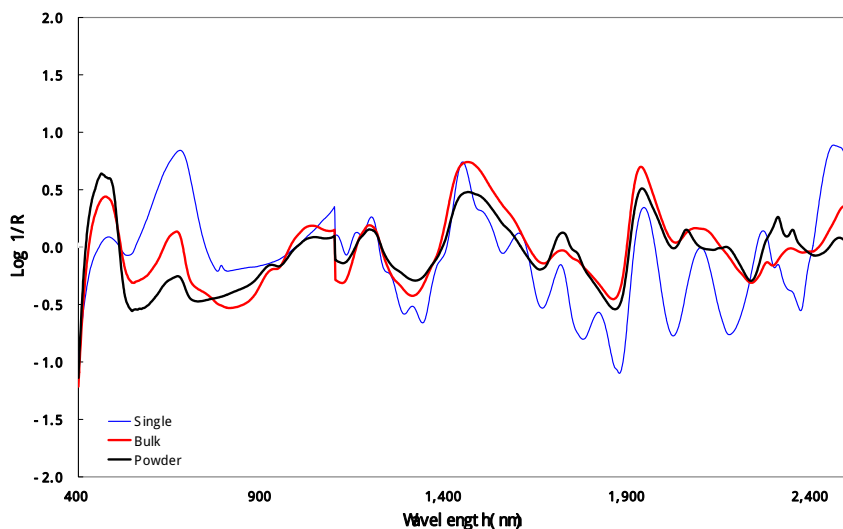

Fig. 6. Typical NIR reflectance spectra of single seed, bulk seed and flour of soybean

NIRS instrument was warmed up, and the stability of NIRS through photometric repeatability (noise test) and wavelength accuracy test was confirmed. The NIRS manipulation for scanning, mathematical processing, and statistical analysis was performed with the WinISI II software (Windows version 1.60, Foss and Infrasoft International LLC, State College, PA). In WinISI software, the Score program was used to select samples for spectrum outliers and samples to represent the entire sample set before calibration and validation. The distance between a sample and its neighbor was measured as the H distance and was used as a criterion for selecting those samples representing the calibration and validation sets. The Score algorithm ranks spectra according to Mahalanobis distance (H distance) from the average spectrum, gives spectral boundaries to eliminate outliers with $H > 3.0$, and to eliminate samples with similar spectra with $H < 0.6$ from neighboring samples for the development of an accurate and robust prediction equation (Fig. 7).

The final number of samples for calibration and validation was variable and based on the cutoff point of H distance, depending on the spectral and chemical variability of samples in the population used for NIRS estimation. The samples were randomly split into two sets using the WinISI program (Table 2). The calibration set was used to calibrate and cross-validate the derived equation, and the other samples were used as an external validation set to test the fit of the developed equations.

| Sample set | | n | Mean (%) | Range (%) | SD |
|-------------|---------|-----|----------|-------------|------|
| Calibration | Protein | 189 | 43.23 | 36.04~51.83 | 3.24 |
| | Oil | 189 | 19.15 | 14.57~24.05 | 2.05 |
| Validation | Protein | 103 | 42.13 | 36.17~49.83 | 3.47 |
| | Oil | 103 | 20.06 | 14.88~23.38 | 2.03 |

Table 2. Laboratory reference value statistics for protein and oil content based on ground soybean seed samples (Choung et al. 2001).

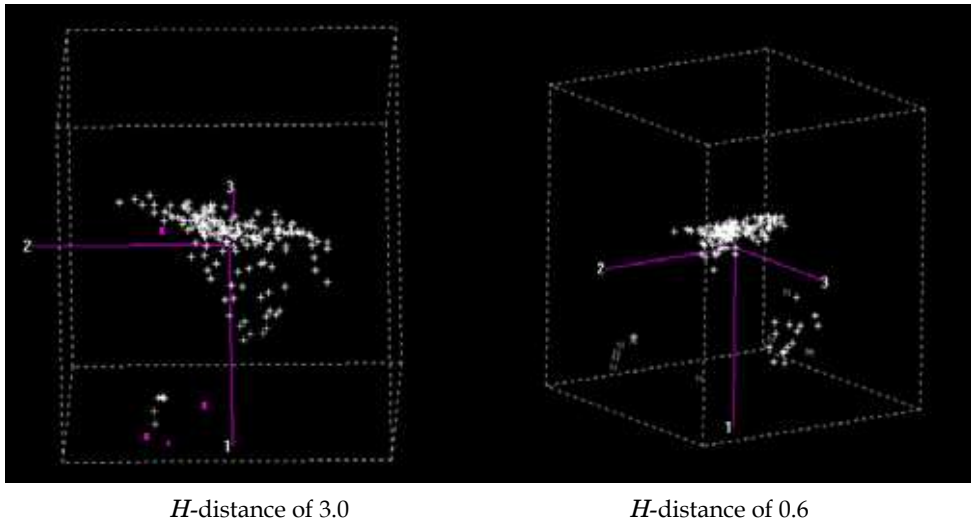

Fig. 7. Examples of eliminating outliers with $H > 3.0$, and $H < 0.6$ for the development of an accurate and robust prediction equations.

3. Data processing

The equations for NIRS prediction were developed using the Global program in WinISI software with modified partial least-squares (MPLS) regression using wavelengths of the entire visible (400-1100 nm) and near-infrared (1100-2500 nm) regions at every 8 nm. In addition to MPLS, regression methods such as PLS (partial least squares), principal component regression, and multiple linear regression were tested to develop calibration for soybean seed composition. Various mathematical treatments using the raw optical spectrum ($\log 1/R$), or first or second derivatives of the $1/R$ data, were applied for calibration equation development. For example, in 2, 10, 10, and 1, the first number 2 indicates the order of the derivative (two is the second derivative of $\log 1/R$), the second number 10 is the gap in data points over which the derivative was calculated, and the third and fourth numbers as 10 and 1, represent the number of data points used in first and second smoothings, respectively. The application of the second-derivative algorithm to the raw spectra ($\log 1/R$) resulted in an increase in the complexity of spectra and a clear separation between peaks, which overlapped in the raw spectra.

In addition to no scatter correction ($\log 1/R$), scatter corrections using the standard normal variate and detrending (SNVD) transformation were evaluated for the calibration. The SNVD was designed to remove additive baseline and multiplicative signal effects resulting in a spectrum with zero mean and a variance equal to one. Application of SNVD transformation to raw spectral data reduces the differences in spectra related to physical characteristics such as particle size and path length of samples.

Calculated calibration statistics included the standard error of calibration (SEC), the coefficient of determination (R^2), and the standard error of cross-validation (SECV). The performances of the different equations obtained in the calibration were determined from cross-validation as an internal validation method. Internal cross validation was used

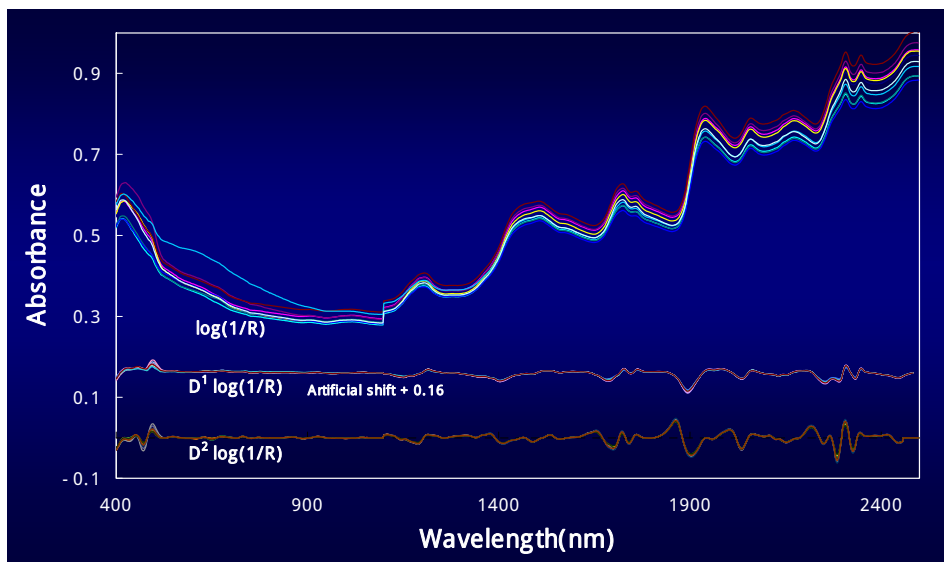

Fig. 8. The raw optical spectrum ($\log 1/R$), or first or second derivatives of the $1/R$ data (unpublished data)

to avoid over fitting the equations by selecting the minimum number of PLS terms in each model. The best predicted equations for each chemical component were selected on the basis of minimizing SECV and increasing R^2 . Two passes to eliminate outliers were set by two outlier detection methods, t and H statistics in WinISI software. The t statistics identified outliers having residuals from reference analysis of >2.5 times the SEC. Outliers indicated that their reference values were in doubt and that the samples were in different populations due to atypical spectra. The ratio (SD/SECV) of the standard deviation of reference data (SD) to SECV, designated RSC, was calculated as a criterion for evaluating the performance of calibrations.

| Constituent | Math treatment | Terms ^a | Calibration | | Cross-validation | | |
|-------------|----------------|--------------------|------------------|--------------------|-------------------|-------------------|------------------|
| | | | SEC ^b | R^2 ^c | 1-VR ^d | SECV ^e | RSC ^f |
| Sucrose | 2,10,10,1 | 6 | 0.220 | 0.941 | 0.921 | 0.255 | 3.29 |
| Raffinose | 0,0,1,1 | 2 | 0.107 | 0.367 | 0.344 | 0.109 | 1.01 |
| Stachyose | 2,8,6,1 | 9 | 0.134 | 0.730 | 0.539 | 0.175 | 1.27 |
| TSCs | 2,10,10,1 | 7 | 0.210 | 0.946 | 0.912 | 0.268 | 3.07 |

^a Number of PLS loading factors in the regression model MPLS (modified partial least-squares). ^bSEC, standard error of calibration. ^c R^2 , coefficient of determination of calibration. ^d1-VR, one minus the ratio of unexplained variance divided by variance. ^eSECV, standard error of cross-validation. ^fRSC, SD/SECV, the ratio of SD (standard deviation of reference data) to SECV in the calibration set.

Table 3. Equation development statistics using MPLS and scatter correction for the NIRS prediction of soluble carbohydrate contents in soybean seeds (Choung, 2010).

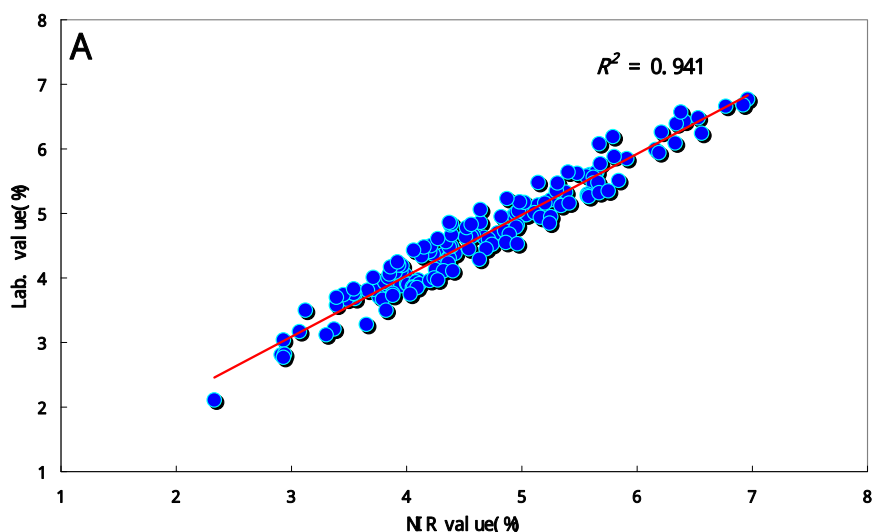

Fig. 9. Scatter plots of sucrose content in soybean seed samples by HPLC vs. by NIRs for the calibration

After calibration, the developed regression equations allowed for accurate analysis of many other samples by prediction of data based on the spectra. In addition to the internal cross-validation, the external validations of calibration models were tested for the prediction capacity on the basis of the standard error of prediction (SEP) and the coefficient of determination in prediction (r^2) (Table 4 and Fig. 9). The ratio of SD for the validation samples to the corrected SEP (designated RSP) was also used as a criterion to evaluate the accuracy of the equations. This RSP value as cutoff point was 3.0 in this study, which is the value recommended for screening purposes. The validation sample set allowed the NIRS equation to be validated for prediction accuracy, using random samples not included in the calibration sample set. The equations for selected chemical composition in intact seeds of soybean were monitored with the Monitor program in WinISI software, using the validation set.

| Constituent | Mean ^a | SD ^b | Bias ^c | r^2 ^d | SEP(C) ^e | RSP ^f |
|-------------|-------------------|-----------------|-------------------|--------------------|---------------------|------------------|
| Sucrose | 4.59 | 0.899 | -0.060 | 0.921 | 0.257 | 3.50 |
| Raffinose | 0.75 | 0.080 | 0.026 | 0.311 | 0.124 | 0.65 |
| Stachyose | 2.33 | 0.203 | 0.002 | 0.443 | 0.226 | 0.89 |
| TSCs | 7.61 | 0.888 | 0.029 | 0.934 | 0.232 | 3.83 |

^aSamples used to monitor the model. ^bSD, standard deviation of mean. ^cBias, average difference between reference and NIRS values. ^d r^2 , coefficient of determination of cross-validation. ^eSEP(C), the corrected standard error of prediction. ^fRSP, SD/SEP(C), the ratio of SD of reference data to SEP(C) in the external validation set.

Table 4. Validation statistics for soluble carbohydrate components in soybean seeds (Choung, 2010).

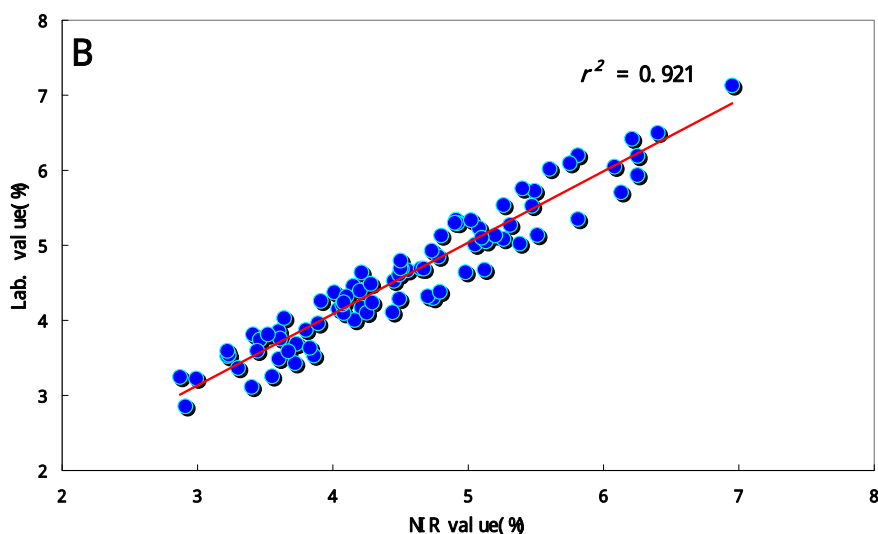

Fig. 10. Scatter plots of sucrose content in soybean seed samples by HPLC vs. by NIR for the external validation sample sets (Choung, 2010).

4. Applications

An overview of applications of NIR spectroscopy to measure the seed composition and products for soybean improvement is given in Table 5. Only information where at least an internal validation has been conducted is included in this chapter. Protein (40%) and oil (20%) are the dominant components of value in soybean seed. Therefore, NIR has been widely used for evaluation of protein and oil in comparison to other seed components (Table 5). In ground soybean flour, protein and oil contents have been accurately estimated using NIRs (Pazdernik et al., 1997; Choung et al., 2001b). However estimation of other seed components in soybean flour using NIR remains labor intensive compared to using non-destructive methods with whole seeds. Therefore, investigators continue to accurately develop and use NIR techniques for measurement of seed components by scanning bulked seed (Fig. 4). For example, Choung et al. (2001a) used 310 soybean samples to develop calibration curves for protein and oil contents in soybean. They reported that validation of NIRs equations showed very low bias (protein: 0.016%, Oil: -0.017%), stand error of prediction (protein 0.568%, oil: 0.451%) and very high coefficient of determination (r^2 Protein: 0.927, oil: 0.906). Presently, NIR spectroscopy in which whole seed can be analyzed without destruction is the method of choice for protein and oil analysis not only in soybean research (Helms & Orf, 1998; Sebolt et al., 2000; Palomeque et al., 2010; Tajuddin et al., 2003, Geater & Fehr, 2000) but also in soybean breeding programs. Estimation of seed composition with NIR using bulked soybean seed is very useful in soybean studies, however several grams of soybean seed are needed for measurements. Estimation of seed components based on analysis of single seeds would be useful. There are interesting reports using single soybean seed for prediction of seed composition in soybean. Tajuddin et al. (2002) developed calibration equations to predict protein and oil content in single soybean seed.

They used single F_8 seed to predict protein and oil content in the F_9 generation and developed good calibration equations with 0.04 – 0.07% bias, 1.32 – 1.57% for low standard error of prediction, and 0.88 – 0.87 of coefficient of determination for protein, and -0.09 – -0.14% bias, 1.06 – 1.37% for standard error of prediction, and 0.72 – 0.80 for coefficient of determination for oil. Recently, NIR spectroscopy to analyze seed protein in single soybean seed was developed by Choung et al. (2004) with high coefficient of determination for protein ($r^2=0.955$) and oil ($r^2 = 0.920$) between analyses comparing wet chemistry and NIR spectroscopy. This NIR method was applied to single seeds in segregating soybean populations by Lee et al. (2010). They developed two segregating populations from crosses between high protein and low protein parents. Protein of parents and F_2 seeds were estimated by NIR spectroscopy to select high and low protein F_2 seeds from the two populations. The selected F_2 high and low protein seeds were planted to produce F_3 seed. Means and ranges of F_3 seeds selected from high protein F_2 seeds were higher in protein than F_3 seeds from low protein F_2 seeds. This indicates that analysis of single F_2 seed for protein content using NIR spectroscopy was effective in selecting for increased protein in the F_3 generation (Fig. 11).

Soybean represented 56% of the world's vegetable oil seed production, and soybean oil was second in world oil consumption (www.soystats.com/ 2009). Soybean oil is primarily composed of five fatty acids, palmitic, stearic, oleic, linoleic and linolenic acids. Levels of

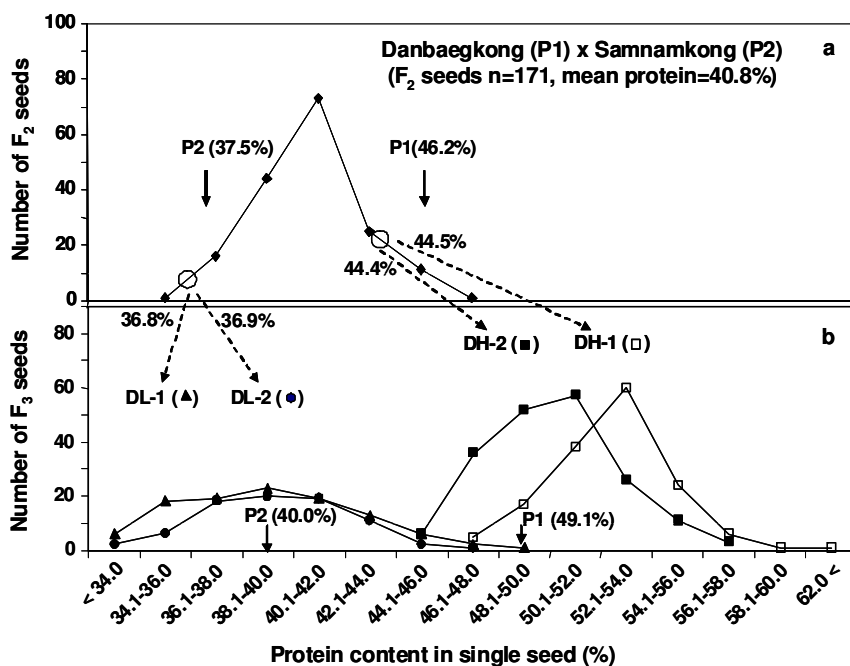

Fig. 11. Protein distribution of F_2 seeds and parents of population Danbaegkong x Samnamkong (a), and of F_3 seeds produced from a plant from a selected F_2 seed (b). F_3 seeds of DL-1, DL-2, DH-1, and DH-2 were from F_2 seed with 36.8, 36.9, 44.5, and 44.4% protein content, respectively (Lee et al., 2010).

each fatty acid in the oil have specific benefits for uses in various food applications with different consequences for human health (Lee et al., 2007). Therefore, a quick and easy method to determine of fatty acid concentration in soybean seed is very important to modify fatty acid levels in breeding programs. Sato et al. (2002) developed reasonable calibration equations for oleic acid ($r^2=0.877$) and linoleic acid ($r^2=0.853$) to determine fatty acid concentration in soybean seed. However, Choung et al. (2005) developed good calibration equations for oleic acid ($r^2=0.974$), linoleic acid ($r^2=0.967$), and linolenic acid ($r^2=0.884$). They suggested that these NIRs equations have potential for use in screening for unsaturated fatty acid content in soybean seed oil. Kovalenko et al. (2006) also reported that NIR equations for total saturates had high predictive ability ($r^2=0.91-0.94$), however unsaturated fatty acids showed low predictive abilities, oleic ($r^2=0.76-0.81$), linolenic ($r^2=0.73-0.76$), and linolenic ($r^2=0.67-0.74$).

NIR spectroscopy also has been used determine soybean oil quality such as determination of degradation in frying oil (Yildize et al., 2001; Gerde et al., 2007), peroxide value in oxidized soybean oil (Yildiz et al., 2003), and *cis* and *trans* content in hydrogenated soybean oil (Li et al., 1999). Determination of minor seed composition by NIR spectroscopy in soybean seed or soybean products was also reported. Calibration equations have been developed for amino acids (Fontain et al., 2001), for inorganic phosphorus by single-seed transmittance spectra ($r^2=0.276$), 24-bean average transmittance spectra ($r^2=0.598$) and meal reflectance spectra ($r^2=0.860$) (Delwiche et al., 2006), determination of nonstarch polysaccharides (Hollung et al., 2005), sucrose content ($r^2=0.941$), raffinose content ($r^2=0.344$), and stachyose content ($r^2=0.730$) (Choung, 2010), total isoflavone content ($r^2=0.95$) from soybean flour (Sato et al., 2008), and anthocyanin, C3G ($r^2=0.952$), D3G ($r^2=0.936$), and Pt3G ($r^2=0.8330$) (Kim et al., 2008).

Interestingly, researchers used NIR spectroscopy to discriminate among levels of disease on soybean plant parts such as soybean seed, pods, etc. Wang et al. (2004) classified fungal-damaged soybean seeds by NIR spectroscopy and reported that classification accuracies of the validation sample set were 100, 99, 84, 94, and 95% for *Phomopsis*, *Cercospora kikuchii*, soybean mosaic virus, and downy mildew damaged seeds, respectively in comparison to healthy seeds. Sirisomboon et al. (2009) investigated NIR spectroscopy to identify defective pods for green soybean processing and reported that the good pod model created by primary spectra correctly classified 77.2% of samples as good pods or defective pods. Jinendra et al. (2010) reported a novel approach for rapid in vivo diagnosis of virus infected soybean by NIR spectroscopy and aquaphotomics results showed that the developed spectral calibration model can predict non-infected and infected soybean 96% and 92% of the time, respectively. Choung et al. (2009) developed a good calibration model for NIR technology that can discriminate between soybean seed with and without the Round-up ready herbicide resistance trait with high predictability ($r^2=0.95$). Choung et al. (2009) also developed NIR calibrations to accurately predict ($r^2=0.945$) seed weight of soybean.

5. Limitations of NIR and future research

Improving the quantity and quality of soybean seed composition and soybean products has long been an objective of soybean researchers. The most attractive merit using NIR spectroscopy is accurate non-destructive analysis of seed samples for various chemical traits. In soybean, the feasibility of NIR spectroscopy to measure quality attributes

| Traits | Source | Spectrometer | Acquisition mode | Spectra range | References |
|--|------------------------------|-------------------|------------------------------|--------------------------------|--------------------------|
| Anthocyanin | Seed coat flour | Scanning | Reflectance | 400-2500 nm | Kim et al., 2008 |
| Fatty acids | Soybean flour | Scanning | Reflectance | 400-2500 nm | Choung et al., 2005 |
| Fatty acids | Soybean flour | Scanning | Reflectance | 1100-2500 nm | Sato et al., 2002 |
| Fatty acids | Soybean flour | Fourier Transform | | 4000-12500 cm ⁻¹ | Sun et al., 2008 |
| Fungal-damaged seed | Single seed | Scanning | Reflectance | 400-1700 nm | Wang et al., 2004 |
| Glycine (11s) and β -conglycinin (7s) | Soybean flour and seeds | Scanning | Transmittance Reflectance | 800 - 1798 nm 1100 -2489 nm | Delwiche et al., 2007 |
| Good soybean pod | Fresh soybean pod | Scanning | Reflectance | 600-1100 nm | Sirisomboon et al., 2009 |
| Inorganic phosphorus | Single seed and soybean meal | Scanning | Transmittance Reflectance | 600-1898 nm 1100-2498nm | Delwiche et al., 2006 |
| Isoflavone | Soybean flour and seeds | Scanning | Reflectance | 1100-2500 nm | Sato et al., 2008 |
| Lecithin | Soybean lecithin | Fourier Transform | Interactance | 4000-12500 cm ⁻¹ | Li et al., 2009 |
| Oil degradation | Soybean oil | Scanning | Reflectance | 350-2500 nm | Gerbe et al., 2007 |
| Oil quality | Soybean oil | Fourier Transform | Interactance | 4000-10000 cm ⁻¹ | Li et al., 1999 |
| Oil quality (oxidation) | Soybean oil | Scanning | Transmittance | 400-2500 nm | Yildiz et al., 2001 |
| Oligosaccharide and nonstarch polysaccharide | Soybean flour and seeds | Scanning | Reflectance | 400-2498 nm | Hollung et al., 2005 |
| Peroxide value | Soybean oil | Scanning | Transmittance | 400-2500 nm | Yildiz et al., 2003 |
| Protein | Single seed | Scanning | Reflectance | 400 -2500 nm | Choung et al., 2004 |
| Protein and Oil | Soybean flour | Scanning | Reflectance | 400-2500 nm | Choung et al., 2001b |
| Protein and Oil | Seed | Scanning | Reflectance | 400-2500 nm | Choung et al., 2001a |
| Protein and Oil | Single seed | Scanning | Transmittance | 700-1100 nm | Tajuddin et al., 2002 |
| Protein, amino acids | Soybean flour | Scanning | Reflectance | 1100-2500 nm | Fontaine et al., 2001 |
| Soybean meal content | Soybean meal | Scanning | Reflectance | 950-1650 nm | Li et al., 2007 |
| Sucrose | Soybean flour | Scanning | Reflectance | 400-2500 nm | Choung, M.G., 2010 |

Table 5. Overview of applications of NIR spectroscopy to evaluate soybean for levels of various important chemical components and traits.

has been shown for many products (Table 5) such as soybean seed composition, discrimination of pest infected or non-infected soybean seeds or pods, and various soybean products. It is clear that the accuracy of the NIR calibration models should be sufficient for analysis of various seed components and soybean; however there are several important issues associated with NIR spectroscopy for accurately measuring important traits for soybean improvement.

First, it is hard to develop good calibration equations for minor seed components with relatively low phenotypic variation. For example, depending on researchers, two saturated fatty acids, palmitic acid and stearic acid showed relatively low coefficient of determination than unsaturated fatty acids. Among unsaturated fatty acids linolenic acid also showed a lower coefficient of determination than oleic acid and linoleic acid (Choung et al., 2005; Kovalenkou et al., 2006; Sun et al., 2008).

Second, the threshold for coefficient of determination of 0.95 or more is important for assuring accurate NIR estimations for various traits. Calibration equations with less than 0.95 coefficient of determinations can be useful for rough screens for measuring soybean genotypes or soybean products for various components of interest. If soybean scientists use the NIR with calibration equations with relatively low coefficient of determinations to measure traits, it is necessary to use other tools such as wet chemistry, or molecular markers to confirm screening data. However, it is clear that even though calibration equations with low coefficient of determination, NIR is still useful to screen samples where a high level of accuracy is not required.

Third, NIR spectroscopy has been widely and accurately used for measuring protein and oil. There is evidence where NIR is useful for measuring levels of amino acids in protein, unsaturated fatty acid in oil and other useful traits. However, prediction equations for traits other than protein and oil need refining for broader use of NIR for measuring levels of other important seed characteristics. Therefore, calibration models should be developed and optimized from large datasets to develop highly accurate calibration equations. Protocols are needed to update calibration models with minimal effort, and collaborative efforts are needed to improve and share NIR spectroscopy technology leading to broader use of NIR technology to efficiently measure more traits.

6. References

- Birt, D.F.; Hendrick, S. & Alekel, D.L. (2004) Soybean and the prevention of chronic human disease, In: *Soybeans: Improvement, Production, and Uses*, Boerma, H.R. & Specht, J.E. (Ed.), pp.1047-1117, ASA-CSSA-SSSA, ISBN 0-89118-154-7, Madison, WI, USA.
- Choung, M.G.; Baek, I.Y.; Kang, S.T.; Han, W.Y.; Shin, D.C.; Kwack, Y.H. & Moon, H.P. (2004). Non-destructive analysis method of one seed grain by near infrared reflectance spectroscopy. Korean Intellectual Property Office Registration No.(Date) 10-0433263-000 (2004.05.18) (Korean with English abstract).
- Choung, M.G. (2010). Determination of sucrose content in soybean using near-infrared reflectance spectroscopy. *J Korean Soc. Appl. Biol. Chem.*, Vol.(53), No.(4), 478-484, ISSN 1738-2203.
- Choung, M.G.; Baek, I.Y.; Kang, S.T.; Han, W.Y.; Shin, D.Ch.; Moon, H.P. & Kang, K.H. (2001a). Non-destructive method for selection of soybean lines contained high protein and oil by near infrared reflectance spectroscopy. *Korean J Crop Sci.*, Vol.(46) , No. (5), 401-406, ISSN 0252-9777.

- Choung, M.G.; Baek, I.Y.; Kang, S.T.; Han, W.Y.; Shin, D.Ch.; Moon, H.P. & Kang, K.H. (2001b). Determination of protein and oil contents in soybean seed by near infrared reflectance spectroscopy. *Korean J Crop Sci.*, Vol.46, No.(2), 106-111, ISSN 0252-9777.
- Choung, M.G.; Hwang, Y.S. & Baek, I.Y. (2009a). Simple determination of seed weights in crops using near infrared reflectance spectroscopy. Korean Intellectual Property Office Registration No.(Date) 10-934410 (2009.02.18).
- Choung, M.G.; Hwang, Y.S.; Kang, S.T.; Baek, I.Y. & Kim, H.T. (2009). Non-destructive discriminant analysis of herbicide tolerance soybean. Korean Intellectual Property Office Registration No.(Date) 10-0883664 (2009.02.18).
- Choung, M.G.; Kang, S.T.; Han, W.Y.; Baek, I.Y.; Kim, H.K.; Kim, K.S. & Park, S.H. (2005). Determination of fatty acid composition in soybean seed using near infrared reflectance spectroscopy. *Korean J Breed.*, Vol.37, No.(4), 197-202, ISSN 0250-3360.
- Davies, A.M.C. (2000). William Herschel and the discovery of near infrared. *Spectrosc. Eur.*, Vol.12, 10-16, ISSN 0966-0941.
- Delwiche, S.R.; Pordesimo, L.O.; Panthee, D.R. & Pantalone, V.R. (2007). Assessing glycinin(11S) and β -conglycinin (7S) fractions of soybean storage protein by near-infrared spectroscopy. *J Am. Oil Chem. Soc.*, Vol.(84), 1107-1115, ISSN 0003-021X.
- Delwiche, S.R.; Pordesimo, L.O.; Scaboo, A.M. & Pantalone, V.R. (2006). Measurement of inorganic phosphorus in soybean with near-infrared spectroscopy. *J Agric. Food Chem.*, Vol.54, No. (19), 6951-6956, ISSN 1520-5118.
- Fontaine, J.; Horr, J.; & Schirmer, B. (2001). Near-infrared reflectance spectroscopy enables the fast and accurate prediction of the essential amino acid contents in soy, rapeseed meal, sunflower meal, peas, fishmeal, meat meal products, and poultry meal. *J Agric. Food Chem.*, Vol.49, No.(1), 57-66, ISSN 1520-5118.
- Geater, C. & Fehr, W.R. (2000). Association of total sugar content with other seed traits of diverse soybean cultivars. *Crop Sci.*, Vol. (40), No. (6), 1552-1555, ISSN 1435-0653.
- Gerde, J.A.; Hardy, C.L.; Hurburgh Jr, Ch.R. & White P.J. (2007). Rapid determination of degradation in frying oils with near-infrared spectroscopy *J Am. Oil Chem. Soc.*, Vol.(84), 519-522, ISSN 0003-021X.
- Han, W.Y.; Park, K.Y.; Choung, M.G.; Kim, H.T.; Ko, J.M.; Baek, I.Y. & Lee, C.Y. (2008). Growth characteristics and qualities of Korean soybean landraces. *Korean J Crop Sci.*, Vol.(53), No. (:89-95, ISSN 0252-9777.
- Helms, T.C. & Orf, J.H. (1998). Protein, oil an yield soybean lines selected for increased protein. *Crop Sci.*, Vol.(38), No.(3), 707-711, ISSN 1435-0653.
- Hollung, K.; Overland, M.; Hrustic, M.; Sekulic, P.; Miladinovic, J.; Martens, H.; Narum, B.; Sahlstrom, S.; Sorensen, M.; Storebakken, T. & Skrede, A. (2005). Evaluation of nonstarch polysaccharides and oligosaccharide content of different soybean varieties (*Glycine max*) by near-infrared spectroscopy and proteomics. *J Agric. Food Chem.*, Vol.(53), No.(23), 9112-9121, ISSN 1520-5118.
- Jinendra, B.; Tamaki, K.; Kuroki, S.; Vassileva, M.; Yoshida, S. & Tsenkova, R. (2010). Near infrared spectroscopy and aquaphotomics: Novel approach for rapid in vivo diagnosis of virus infected soybean. *Biochemical and Biophysical Research Communications*, Vol.(397), No.(4), 685-690, ISSN 0006-291X.
- Kanamaru, K.; Wang, S.; Abe, J.; Yamada, T. & Kitamura, K. (2006). Identification and characterization of wild soybean (*Glycine soja* Sieb. et Zecc.) strains with high lutein content. *Breed. Sci.*, Vol.(56), No.(3), 231-234, ISSN 1347-3735.

- Kim, K.S.; Park, S.H. & Choung, M.G. (2007). Nondestructive determination of oil content and fatty acid composition in perillia seed by near-infrared spectroscopy. *J Agric. Food Chem.*, Vol.(55), No.(5), 1679-1685, ISSN 1520-5118.
- Kim, Y.H.; Ahn, H.K.; Lee, E.S. & Kim, H.D. (2008). Development of prediction model by NIRS for anthocyanin contents in black colored soybean. *Korean J Crop Sci.*, Vol.(53), No.(1), 15-20, ISSN 0252-9777.
- Kovalenko, I.V.; Rippke, G.R. & Hurburg, C.R. (2006). Measurement of soybean fatty acid by near-infrared spectroscopy: Liner a nonlinear calibration methods. *J Am. Oil Chem. Soc.*, Vol.(83), 421-427, ISSN 0003-021X.
- Lee, J.D.; Bilyeu, K.D. & Shannon, J.G. (2007). Genetics and breeding for modified fatty acid profile in soybean seed oil. *J Crop Sci. Biotech.*, Vol.10, No.(4), 201-210, ISSN 1975-9479.
- Lee, J.D.; Shannon, J.G. & Choung, M.G. (2010). Selection for protein content in soybean from single F₂ seed by near infrared reflectance spectroscopy. *Euphytica*, Vol.(172), No.(1), 117-123, ISSN 0014-2336.
- Li, H.; Goulden, M.; Cocciardi, R. & Hughes, G. (2009). Fourier transform near infrared spectroscopy as a quality control tool for the analysis of lecithin and by-products during soybean oil processing. *J Am. Oil Chem. Soc.*, Vol.(86), 835-841, ISSN 0003-021X.
- Li, H.; Lv, X.; Wang, J.; Li, J.; Yang, H. & Qin Y. (2007). Quantitative determination of soybean meal content in compound feeds: comparison of near-infrared spectroscopy and real-time PCR. *Anal. Bioanal. Chem.*, Vol.(389), No.(7-8), 2313-2322, ISSN 1618-2642.
- Li, H.; Voort, F.R.; Sedman, J. & Ismail, A.A. (1999). Rapid Determination of *cis* and *trans* content, iodine value, and saponification number of edible oils by fourier transform near-infrared spectroscopy. *J Am. Oil Chem. Soc.*, Vol.(76), No.(4), 491-497, ISSN 0003-021X.
- Nicolai, B.M.; Beullens, K.; Bobelyn, E.; Peirs, A.; Saeys, W.; Theron, K.I. & Lammertyn, J. (2007). Nondestructive measurement of fruit and vegetable quality by means of NIR spectroscopy: A review. *Postharvest Biology and Technology*, Vol.(46), No.(2), 99-118. ISSN 0925-5214.
- Palomeque, L.; Liu, L.J.; Li, W.; Hedges, B.R.; Cober, E.R.; Smid, M.P.; Lukens, L. & Rajcan, I. (2010). Validation of mega-environment universal and specific QTL associated with seed yield and agronomic traits in soybeans. *Theor. Appl. Genet.*, Vol.(120), No.(5), 997-1003, ISSN 0040-5752.
- Pezdernik, D.L.; Killam, A.S. & Orf, J.H. (1997). Analysis of amino and fatty acid composition in soybean seed, using near infrared reflectance spectroscopy. *Agron. J*, Vol.(89), No.(4), 679-685, ISSN 1435-0645.
- Sato, T.; Eguchi, K.; Hatano, T. & Nishiba, Y. (2008). Use of near-infrared reflectance spectroscopy for the estimation of the isoflavone contents of soybean seeds. *Plant Prod. Sci.*, Vol.11, No.(4), 481-486, ISSN 1349-1008.
- Sato, T.; Takahashi, M. & Matsunaga, R. (2002). Use of NIR spectroscopy for estimation of FA composition of soy flour. *J. Am. Oil Chem. Soc.*, Vol.(79), No.(6), 535-537, ISSN 0003-021X.

- Sebolt, A.M.; Shoemaker, R.C. & Diers, B.W. (2000). Analysis of a quantitative trait locus allele from wild soybean that increases seed protein concentration in soybean. *Crop Sci.*, Vol. (40), No.(5), 1438-1444, ISSN 1435-0653.
- Sirisomboon, S.; Hashimoto, Y. & Tanaka, M. (2009). Study on non-destructive evaluation methods for defect pods for green soybean processing by near-infrared spectroscopy. *Journal of Food Engineering*, Vol.(93), No.(4), 502-512, ISSN 0260-8774.
- Sun, J.M.; Han, F.X.; Yan, S.R.; Yang, H. & Tetsuo, S. (2008). Rapid determination of fatty acids in soybeans (*Glycine max* (L.) Merr.) by FT-near-infrared reflectance spectroscopy. *Spectroscopy and Spectral Analysis*, Vol.(28), No.(6), 1290-1295, ISSN 1000-0593.
- Tajuddin, T.; Watanabe, S.; Masuda, R.; Harada, K. & Kawano, S. (2002). Application of near infrared transmittance spectroscopy to the estimation of protein and lipid contents in single seeds of soybean recombinant inbred for quantitative trait loci analysis. *J Near Infrared. Spectrosc.*, Vol.(10), No.(4), 315-325, ISSN 0967-0335.
- Tajuddin, T.; Watanabe, S.; Yamanaka, N.; Harada, K. (2003) Analysis of quantitative trait loci for protein and lipid contents in soybean seed using recombinant inbred lines. *Breed. Sci.*, Vol.(53), No.(2), 133-140, ISSN 1347-3735.
- Wang, D.; Dowell, F.E.; Ram, M.S.; & Schapaugh, W.T.(2004). Classification of fungal-damaged soybean seeds using near-infrared spectroscopy. *International journal of food properties*, Vol.(7), No.(1), 75-82, ISSN 1094-2912.
- Wilson, R.F. (2004). Seed composition, In: *Soybeans: Improvement, Production, and Uses*, Boerma, H.R. & Specht, J.E. (Ed.), pp. 624-677, ASA-CSSA-SSSA, ISBN 0-89118-154-7, Madison, WI, USA
- Yildiz, G.; Wehling, R.L. & Cuppett, S.L. (2001). Method for determination oxidation of vegetable oils by near-infrared spectroscopy. *J Am. Oil Chem. Soc.*, Vol.(78), No.(5), 495-502, ISSN 0003-021X.
- Yildiz, G.; Wehling, R.L.; & Cuppett, S.L. (2003). Comparison of four analytical methods for the determination of peroxide value in oxidized soybean oils. *J Am. Oil Chem. Soc.*, Vol.(80), No.(2), 103-107, ISSN 0003-021X.

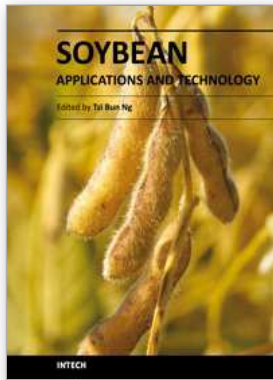

Soybean - Applications and Technology

Edited by Prof. Tzi-Bun Ng

ISBN 978-953-307-207-4

Hard cover, 402 pages

Publisher InTech

Published online 26, April, 2011

Published in print edition April, 2011

Soybean is an agricultural crop of tremendous economic importance. Soybean and food items derived from it form dietary components of numerous people, especially those living in the Orient. The health benefits of soybean have attracted the attention of nutritionists as well as common people.

How to reference

In order to correctly reference this scholarly work, feel free to copy and paste the following:

Jeong-Dong Lee, J. Grover Shannon and Myoung-Gun Choung (2011). Application of Nondestructive Measurement to Improve Soybean Quality by Near Infrared Reflectance Spectroscopy, Soybean - Applications and Technology, Prof. Tzi-Bun Ng (Ed.), ISBN: 978-953-307-207-4, InTech, Available from: <http://www.intechopen.com/books/soybean-applications-and-technology/application-of-nondestructive-measurement-to-improve-soybean-quality-by-near-infrared-reflectance-sp>

INTECH

open science | open minds

InTech Europe

University Campus STeP Ri
Slavka Krautzeka 83/A
51000 Rijeka, Croatia
Phone: +385 (51) 770 447
Fax: +385 (51) 686 166
www.intechopen.com

InTech China

Unit 405, Office Block, Hotel Equatorial Shanghai
No.65, Yan An Road (West), Shanghai, 200040, China
中国上海市延安西路65号上海国际贵都大饭店办公楼405单元
Phone: +86-21-62489820
Fax: +86-21-62489821

© 2011 The Author(s). Licensee IntechOpen. This chapter is distributed under the terms of the [Creative Commons Attribution-NonCommercial-ShareAlike-3.0 License](#), which permits use, distribution and reproduction for non-commercial purposes, provided the original is properly cited and derivative works building on this content are distributed under the same license.

Solid State Fermentation of Soybean Hulls for Cellulolytic Enzymes Production

Khushal Brijwani and Praveen V. Vadlani

Bioprocessing Laboratory, Department of Grain Science and Industry, Kansas State University, Manhattan, Kan. USA

1. Introduction

Soybean hulls are the byproduct of soybean processing and accounts for 5-8% of the 96 million metric tons soybean crop of 2006 in USA (Mielenz et al., 2009). It is mechanically removed from the soybeans during the process of dehulling and commercially sold as it is or in form of compressed pellets mostly for the feed industry (Marshall and Wartelle, 2003). Soybean hulls have rich cellulosic composition, notably half of the composition is cellulosic i.e. cellulose and hemicellulose combined (Brijwani et al., 2010). Fungal solid state fermentation (SSF) of soybean hulls for cellulolytic enzyme production is a useful way of value addition of this under-utilized byproduct. A cellulolytic enzyme system is group of enzymes that work synergistically to hydrolyze lignocellulosic biomass. It is composed of endoglucanase (endo-1, 4- β -D--glucanase, EC 3.2.1.4), exoglucanase (1,4- β -D-glucan-cellobiohydrolase, EC 3.2.1.91), and β -glucosidase (β -D-glucoside glucanohydrolase, cellobiase, EC 3.2.1.21) (Holker et al., 2004; Esterbauer et al., 1991). Xylanase (EC 3.2.1.8), though not part of the group, complements the cellulolytic enzyme system as it is needed to elicit complete and efficient hydrolysis of the lignocellulosic biomass, which has an appreciable amount of hemicellulose or xylan (Brijwani et al., 2010; Brijwani, 2011). It has been widely accepted that Solid State Fermentation (SSF) is an attractive means to produce cellulase economically because of its lower capital investment and lower operating cost (Cen and Xia 1999). Further, the ability of SSF to minimize catabolite repression has been already described for several enzymes (Aguilar and Huitron 1986; Archana and Satayanaryana 1997; Siqueira et al. 1997; Solis-Pereyra 1996). SSF is defined as a fermentation process in which microorganisms grow on solid materials without the presence of free liquid and the moisture necessary for microbial growth exists in adsorbed state or complexed with solid matrix (Krishna, 2005). Both bacteria and fungi are known to produce cellulases using complex cellulosic substrates, however, fungal enzymes are generally complete comprising of all the cellulosic activities (Stockton et al., 1991).

The operating conditions like temperature, pH and moisture content are very important for microbial growth and efficient cellulase production in SSF. Optimization of parameters in multifactor experimental designs fall short in locating true optimum especially when there are interactions among independent variables, besides being time consuming (Giovanni 1983; Theodore and Panda 1995). One of the worthwhile techniques to identify the explanatory variable in the system is Response Surface Methodology (RSM) (Maddox and Richer 1977;

Hounsa et al. 1996). RSM is a collection of statistical techniques for designing experiments building models, evaluating the effect of factors and obtaining optimum conditions for desirable responses. RSM can be used to evaluate the significance of several factors especially when interactions exist among factors, and they are complex to determine (Liu and Tzeng 1998). RSM has been widely adopted among investigators in the field of bioprocessing and has been used to quantify complex interplay of parameters affecting biological system.

In SSF for cellulase production, cellulosic substrate acts as both the carbon source and as an inducer for cellulase production (Cen and Xia 1999). The crystallinity of cellulosic substrate influence the rate of hydrolysis, for instance, amorphous cellulose is readily digestible while crystalline cellulose requires synergistic action of both exo- and endo-glucanases (Mes-Hartree et al., 1988). SSF can be viewed as a discrete solid phase in which microorganisms grow on the surface of moist, discrete particles as well as inside and between them. The space between particles is occupied by a continuous gas phase (Botella et al., 2009). Availability of oxygen in the open spaces between particles is a major challenge in SSF (Thibault et al., 2000; Oostra et al., 2001). Physicochemical characteristics, crystallinity, bed porosity and specific volumetric surface, of the substrate (soybean hulls) could be vital for the induction of cellulolytic enzyme system in fungal cultures. In this chapter we have delineated the importance of soybean hulls as a substrate for cellulolytic enzyme production using SSF technique. We have discussed the role of symbiotic association of two fungal species in production of complete and balanced cellulolytic enzyme system from soybean hulls, and the use of optimization technique such as RSM for improved and standardized production of cellulases. Since the substrate features are central to enzymatic synthesis in fungal SSF, the final section of this chapter discusses the role of physicochemical characteristics in cellulolytic enzymes synthesis. There is plethora of information available on compositional features of substrate; however, studies on physical nature of substrate in inducing cellulolytic enzyme system is limited (Brijwani, 2011). We believe elucidating the significance of physicochemical characteristics would provide process designers an efficient tool in directing the production of various enzyme activities of the cellulolytic enzyme system as dictated by their end use application.

2. Soybean hulls as a substrate in solid state fermentation

Soybean hulls have rich cellulosic composition (cellulose - 33.49%, hemicellulose - 17.15%) and are low in lignin (9.88%) (Brijwani et al., 2010). Notably the rich cellulosic composition is appropriate for fungal growth and cellulase production. Carbon to nitrogen ration (C/N) is important determinant of SSF process efficiency (Krishna, 2005). Soybean hulls are lower in protein content (~10%) and often supplementation with good nitrogen source like wheat bran with protein content of approximately 20% is a judicious choice. Brijwani et al. (2010) showed that supplementation of four parts of soybean hulls with one part of wheat resulted in high titers of enzymes with balanced proportion of various activities. The 1:1 ratio of filter paper units and beta-glucosidase is generally recognized as balanced enzyme system that is able to overcome glucose inhibition of cellulases and drives reaction forward (Chahal et al., 1992; Mandels et al., 1981).

3. Mixed fungal solid state fermentation and response surface optimization

Fungal strains that produce cellulases are mainly comprised of *Trichoderma*, *Aspergillus*, *Penicillium* and *Fusarium* genera. *Trichoderma reesei* is the most widely employed fungus for

production of cellulolytic enzymes and has been extensively studied (Stockton et al. 1991). Strains of *Trichoderma* can accumulate high activities of endo and exo-glucanase, but are poor in β -glucosidase (Duff et al. 1987) whereas the strains of *Aspergillus* are high in β -glucosidase activity (Grajek 1987). Therefore, strains of both *Trichoderma* and *Aspergillus* can be successfully employed together in solid state fermentation for the production of multicomplex cellulase system. Brijwani et al. (2010) demonstrated that co-culturing of *T. reesei* with *A. oryzae* in 1:1 ratio significantly improved the production of beta-glucosidase levels in SSF of soybean hulls supplemented with wheat bran compared to mono culture of *T. reesei*.

A second order quadratic model (equation 1) comprising of main effects and interaction effects of three vital process variables – temperature (X_1 , °C), pH (X_2), and moisture (X_3 , %) was fitted to experimental data of mixed culture fermentation of wheat bran supplemented with soybean hulls using central composite rotatable design (CCRD). The process variables were varied at two levels each and five central points were replicated for better estimation of error variance (Brijwani et al., 2010).

$$y = \beta_0 + \sum_{i=1}^3 \beta_i x_i + \sum_{i=1}^3 \beta_{ii} x_i^2 + \sum_{i=1}^2 \sum_{j=i+1}^3 \beta_{ij} x_i x_j \quad (1)$$

where, y = predicted response, β_0 = constant coefficient, β_i = linear coefficient, β_{ii} = quadratic coefficient, and β_{ij} = interaction coefficient.

The analysis of variance (ANOVA) and three dimensional surface plots were generated using Design Expert 7.1. The optimized values of three independent variables for maximum activities were determined using numerical optimization package of Design Expert 7.1. Numerical optimization searches the design space using fitted model to find the optimized values of independent variables that maximize cellulase and β -glucosidase activities. Optimization was carried out with respect to filter paper units and beta-glucosidase activity. Both filter paper units (indicator of total cellulase activity: exo- and endo-cellulase combined) and beta-glucosidase are the lead activities needed for efficient hydrolysis of lignocellulosic biomass.

3.1 Cellulase optimization and model fitting

Maximum cellulase activity (10.55 FPU/g of dry substrate) was observed at pH 4.5, moisture content of 70%, and temperature of 30°C. The overall second order polynomial equation for cellulase activity as measured in terms of FPU (Filter Paper Units)/g was:

$$Y = 7.95 + 0.76X_1 + 0.34X_2 + 2.97X_3 + 0.21X_1X_2 + 0.82X_1X_3 - 0.026X_2X_3 - 2.56X_1^2 - 0.40X_2^2 - 1.10X_3^2 \quad (2)$$

The lower p-value and insignificant lack of fit was obtained with quadratic model that suggested good fit. Higher coefficient of regression (>95%) suggested that there was good agreement between predicted and estimated cellulase activity under different conditions of temperature, pH and moisture content. Coefficients and p-values of the model indicated that temperature and moisture content significantly affected the cellulase production. While, moisture content had linear effect on cellulase activity temperature had quadratic effect. The interaction effect of moisture and temperature was significant as compared to their corresponding interactions with pH.

The surface plots were made as function of temperature and pH, moisture content and temperature, and pH and moisture content (Fig. 1). At lowest temperature and low pH (Fig. 1a) the cellulase activity was lowest. Increasing the temperature with moderate increase in pH keeping moisture content fixed at 57.5%, resulted in an increased cellulase activity, which reached its maximum in the vicinity of 30°C. Further increase in temperature resulted in a drop in cellulase activity even at increased pH value. Keeping the pH constant at 4.50 the interaction of moisture and temperature in presented in Fig. 1b. It is evident that with increase in moisture and temperature, the cellulase activity increased. Increasing the temperature beyond 34°C resulted in reduced cellulase activity and maximum activity could be seen in the neighborhood of 70% moisture and 33°C. Similarly, keeping the temperature constant at 30°C and observing for interaction between pH and moisture (Fig. 1c) we found that with increase in moisture and pH, cellulase activity increased and reached maximum around 65% moisture content and pH > 4.25. Our results are in consonance with the results of (Latifian et al. 2007) who have reported that moisture had a significant effect on cellulase production using *T. reesei* QM 9414 and *T. reesei* MCG 77 and maximum enzyme activity was observed at 70% moisture content. They adopted the RSM approach and further reported a temperature and moisture content range of 25-30°C and 55-70%, respectively, for optimal cellulase production.

3.2 Beta-glucosidase optimization and model fitting

The maximum response (8.13 IU/g of dry substrate) occurred at 70% moisture content at pH of 4.5 and incubation temperature of 30°C. β -glucosidase data was fitted to a quadratic model with the following equation:

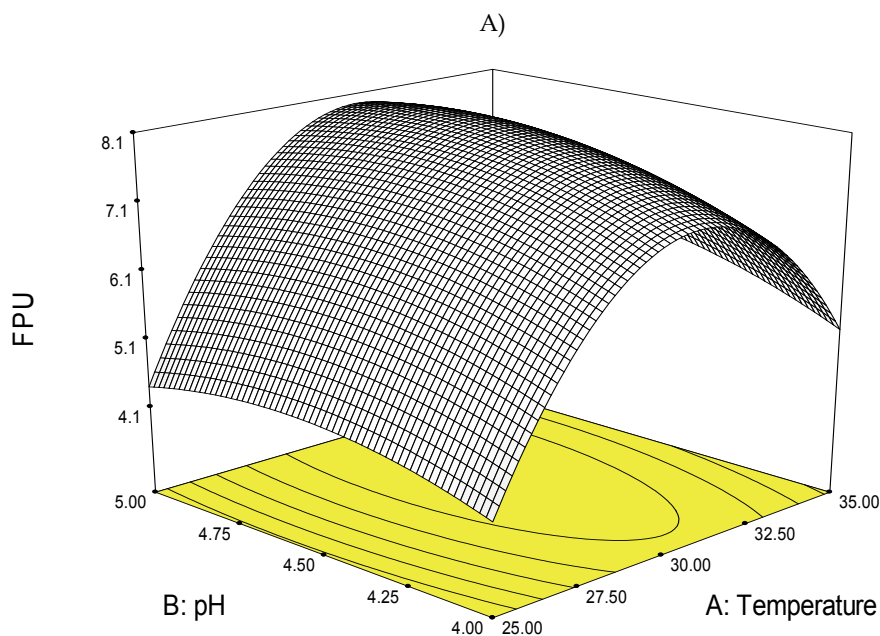

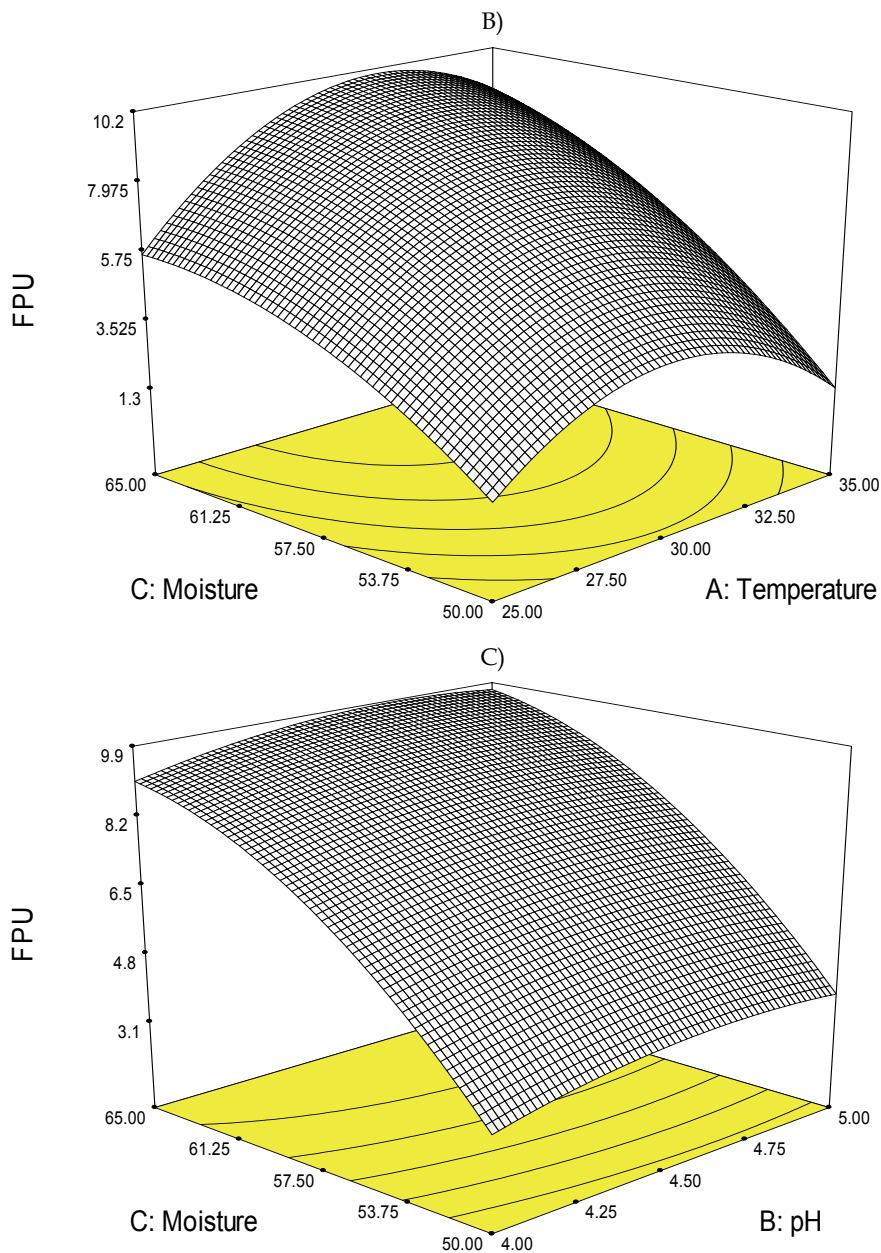

FPU: Filter Paper Units/g of dry substrate

Fig. 1. Surface plots illustrating the effect of A) temperature and pH, B) moisture and temperature, C) moisture and pH on cellulase activity measured as FPU (Filter Paper Units)/g dry substrate

$$Y = 4.90 + 0.25X_1 - 0.33X_2 + 1.73X_3 + 0.69X_1X_2 + 1.03X_1X_3 + 0.42X_2X_3 - 1.32X_1^2 - 0.24X_2^2 - 0.41X_3^2 \quad (3)$$

The lower p-value and insignificant lack of fit was obtained with quadratic model that suggested good fit. Higher coefficient of regression (>85%) suggested that there was good agreement between predicted and estimated cellulase activity under different conditions of temperature, pH and moisture content. Coefficients and corresponding p-values indicated that moisture and temperature had significant effect on β -glucosidase activity. While effect of moisture was linear the effect of temperature was quadratic. The interaction effects of three independent variables were not significant; however, interaction between moisture and pH was considerable.

The surface plots were made as function of temperature and pH, moisture content and temperature, and pH and moisture content (Fig. 2). At a fixed moisture content of 57.5% increasing the temperature and pH beyond 27.5 °C and 4.5, respectively, resulted in increased β -glucosidase activity which was maximum in the neighborhood of 32°C (Fig. 2a). At fixed pH of 4.5, by increasing moisture content and temperature, β -glucosidase activity increased and achieved maxima around 32°C and 65% moisture (Fig. 2b). At constant temperature of 30°C, β -glucosidase activity, increased with increasing moisture levels and showed maximum activity near 62% moisture content (Fig. 2c). The earlier studies conducted on RSM optimization (Singhania et al. 2007) using wheat bran employing *T. reesei* Rut C-30 reported a combination of 37.5% and 30°C as optimal conditions for moisture content and temperature, respectively, for maximum enzyme production; however, enzyme yields reported by them are substantially lower than the values obtained in this study. Further, enzyme yields also depend upon the substrates used and the interaction between substrate and moisture. This interaction depends on the water binding capacity of the substrates and availability of water for the growth of an organism.

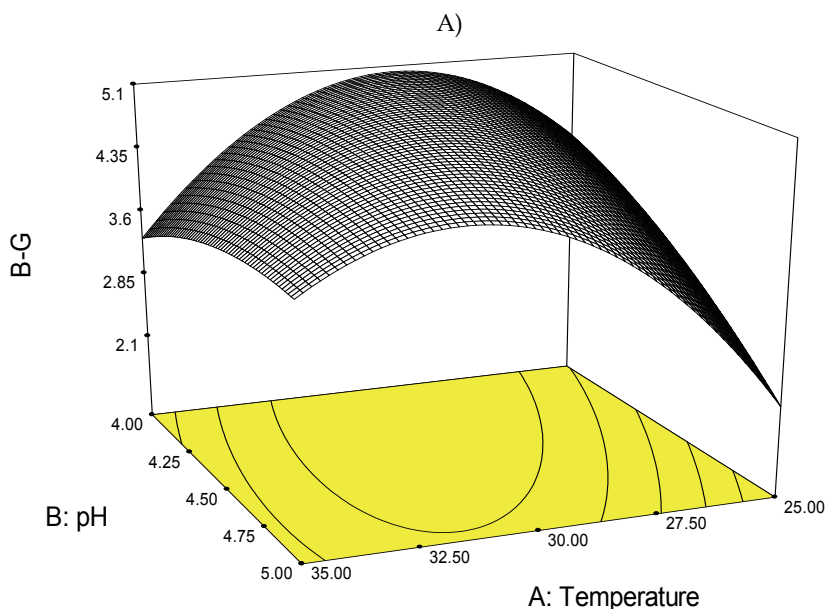

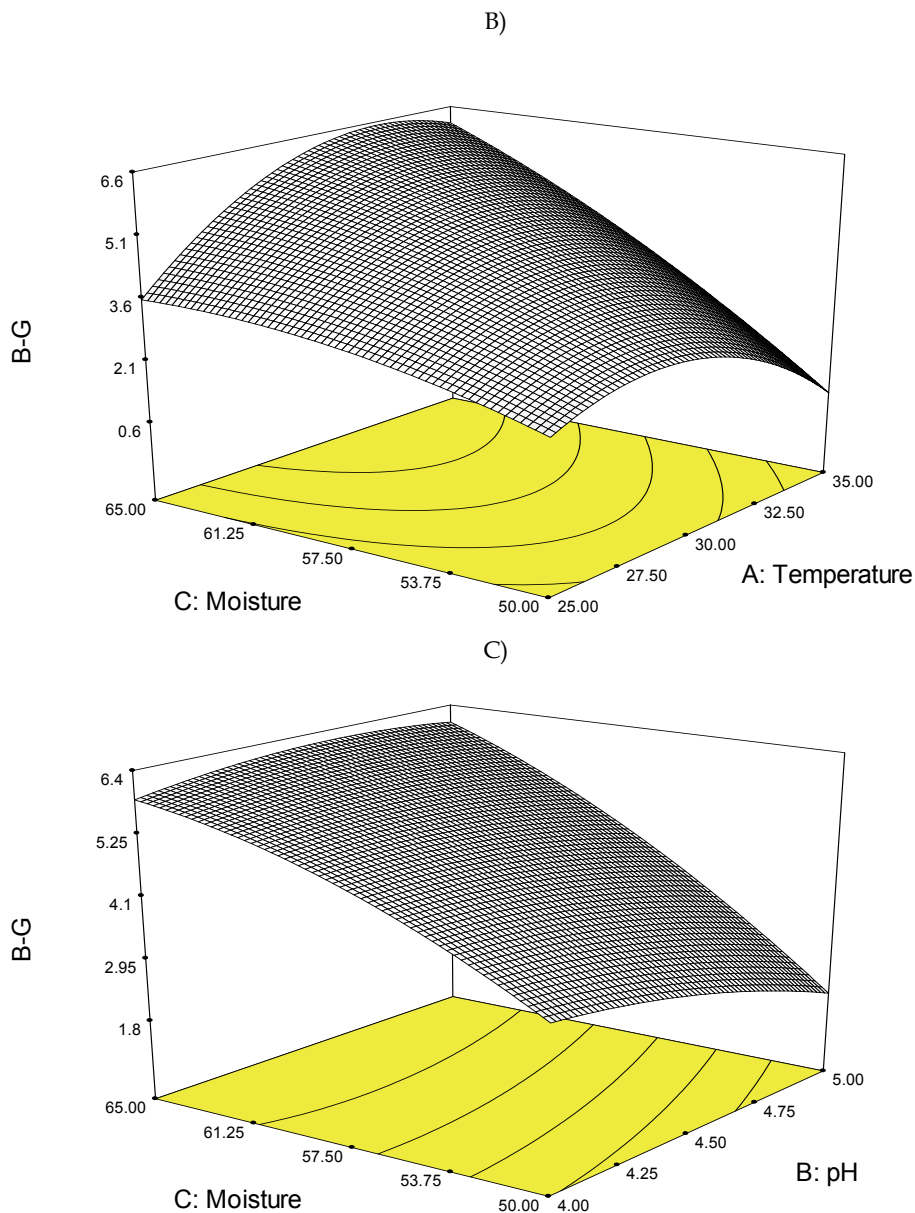

B-G: β -glucosidase activity as IU/g of dry substrate

Fig. 2. Surface plots illustrating the effect of A) temperature and pH, B) moisture and temperature, C) moisture and pH on β -glucosidase (B-G) activity measured as IU (International Units)/g dry substrate

3.3 Numerical optimization of independent variables to maximize cellulase and β -glucosidase activities

Using Design Expert 7.1 numerical optimization subroutine design space was explored with fitted quadratic model to arrive at optimum temperature, moisture and pH conditions that maximize cellulase and β -glucosidase activities. In this task, goals were set to achieve maximum activities of cellulase and β -glucosidase by setting independent variables within the range of upper and lower limit. The optimized variables were found using desirability objective function that assigns relative importance to the responses. Solutions with higher desirability gave optimum temperature of 30 °C, pH of 5 and moisture content of 70%, and the corresponding cellulase and β -glucosidase activities were 10.55 FPU/g and 8.13 IU/g, respectively. Evidently, co-culturing of fungal cultures in SSF with proper optimization resulted in balanced production of enzymes with desired 1:1 ratio of filter paper units and beta-glucosidase activity.

4. Physicochemical characteristics of soybean hulls and production of cellulolytic enzyme system in fungal solid state fermentation

In solid state fermentation, substrate acts as both carrier and source of carbon for growth and productivity of fungal cultures. In literature, numerous studies have highlighted the importance of composition of carbon substrate in induction of cellulolytic enzyme system (Aro et al., 2005, Mach and Zeilinger, 2003; Bisaria and Mishra, 1989). Due to the discrete nature of SSF, the particulate nature of substrate becomes directly manifested such that the physicochemical characteristics: crystallinity, bed porosity and volumetric specific surface, can influence the production of cellulolytic enzyme system in fungal cultures (Brijwani, 2011). The relationship of cellulolytic enzyme system with physicochemical characteristics has been investigated in fungal cultures of *T. reesei* and *A. oryzae* present as mono and mixed forms (Brijwani, 2011). By subjecting soybean hulls to mild pretreatments (steam, and ambient temperature acid and alkali pretreatment) it was possible to alter the physicochemical characteristics without changing the total cellulosic composition of soybean hulls (Brijwani, 2011). Before going into details of the relationship of physicochemical characteristics with cellulolytic enzyme production it is vital to shed light on the techniques for measuring the physicochemical characteristics. Measurement of crystallinity is an arduous task especially for heterogeneous substrate like soybean hulls. With interlocking amorphous and crystalline regions there is dispersion in the scattering; consequently, the peak separation becomes challenging and accurate determination of crystallinity is compromised. In the forthcoming section elaborate details on techniques for measuring crystallinity of soybean hulls is presented. For measurement of other two physicochemical properties: bed porosity and volumetric specific surface, readers are directed to the recent work of Brijwani and Vadlani (2010).

4.1 X-ray diffraction studies of soybean hulls for measurement of crystallinity

Wide angle X-ray diffraction has been extensively used to measure the crystallinity of cellulosic substrates. There are several ways to measure crystallinity in the polymeric sample from an X-ray diffractogram; the most common is the Segal method (Segal et al., 1959). The method requires that amorphous material diffracts with the same intensity at 18° (~ 10 $\bar{1}$ plane) and 22° (002 plane) and that the crystalline cellulose does not contribute to the reflection at 18°. However, all materials give rise to X-ray scattering, and ensuring the

crystalline component does not produce similar reflection at certain scan angles would be difficult. In particular, when large quantities of amorphous hemicellulose and lignin with cellulose are present (as evident in lignocellulosic biomass), the scattering becomes diffusive and spread out. This creates difficulty in separating amorphous reflections from crystalline reflections. Because of the large crystallite size in pure crystalline substances, scattering is quite sharp and diffusive patterns can be avoided or at least minimized. However, in substrates with small crystallite size (20-50 Å), such as lignocellulosic biomass, separating amorphous scattering from crystalline scattering would no longer be trivial and would have serious overlaps (Thygesen et al., 2005; Kasai and Kakudo, 2005). Thus, we briefly present some of the other refined methods described in the literature that can be successfully used to determine crystallinity (a useful parameter in successful utilization of biomass for fuels and chemicals and an important parameter in this study) of lignocellulosic biomass.

Earlier developments in measuring crystallinity of polymeric substances with paracrystalline distortions (owing to amorphous scattering) took place with the work of Ruland (Ruland, 1961) and Vonk (Vonk, 1973). This method involves separation of crystalline peaks from amorphous peaks. The amorphous part of the scattering is obtained from standard amorphous substances, the reflections are then scaled down below the crystalline reflections, and the fraction of integrated intensity of the crystalline phase out of total intensity including the amorphous background is referred to as crystallinity of the sample. That approach was further refined as the Rietveld refinement (Rietveld, 1967; Rietveld, 1969), which uses the full diffraction pattern in a least squares fitting numerical procedure to fit the complete X-ray diffractograms including the background or diffusive scattering due to amorphous regions.

Several shape functions can fit the complete X-ray diffractograms using least squares fitting. However, it is very important to understand the three major sources that contribute to the shape function of the observed X-ray profile (Taupin, 1973): structure of material under consideration, spectral distribution of the X-ray source, and instrumental or non-spectral contributions. The observed profile $h(2\theta)$ is a convolution (Θ) of the intrinsic specimen profile $f(2\theta)$ with the spectral distribution (W) and the instrumental function (G) superimposed over the background b (Garvey et al., 2005):

$$h(2\theta) = [(W\Theta G)\Theta f](2\theta) + b \quad (4)$$

The Voigt function, which is a convolution of Gaussian and Lorentzian peak functions, would include both Gaussian intrinsic broadening of the specimen along with the Lorentzian instrumental profile that considers the background from amorphous scattering. The Voigt function, therefore, appropriately mimics the three major sources presented above. Using the Voigt function intensity of the reflection is represented by following equation:

$$f(2\theta) = \frac{a_0 \int_{-\infty}^{\infty} \frac{\exp(-(2\theta)^2)}{a_1^2 + \left(\frac{x-a_c}{a_g} - 2\theta\right)^2} d(2\theta)}{\int_{-\infty}^{\infty} \frac{\exp(-(-(2\theta)^2))}{a_1^2 + (2\theta)} d(2\theta)} \quad (5)$$

Where a_0 is the amplitude of the peak, a_c is the center of the peak, a_1 is the width of the Lorentzian component, and a_g is the width of the Gaussian component of the peak. The

whole process involves nonlinear least squares fitting of the Voigt function from the Peakfit program to full X-ray diffractograms. The major reflective planes in cellulosic material corresponding to following Miller indices (hkl) were identified: 101, 10 $\bar{1}$, 002, 021, and 040 (Liu et al., 2005); 002 was the prominent reflection representing crystalline cellulose (sometimes resolved into 021 plane as well). The program was re-run locking these planes, and, consequently, five Voigt functions were fitted. The goodness of fit was assessed using R². Crystallinity was calculated from equation (6) (Wada and Okano, 1997),

$$X_{cr}(\%) = \frac{I_{002} + I_{021}}{I_{101} + I_{10\bar{1}} + I_{002} + I_{021} + I_{040}} \times 100 \quad (6)$$

Where I followed by a subscript represents the integrated intensity of the particular Bragg plane. Five Bragg planes (subscripts of I in equation 6) have been generally identified in cellulosic samples from plant materials (Liu et al., 2005). Crystallinity, therefore, represents the fraction of α -cellulose represented by planes 002 and 021 present in a particular sample.

4.2 Effect of various pretreatments on physicochemical characteristics of soybean hulls

The X-ray diffractograms for five substrates: native soybean hulls (untreated), steam pretreated soybean hulls (121 °C, 15 psi), HCl pretreated soybean hulls (ambient temperature treatment with 1N HCl using 5% soybean hulls slurry for 24 h), H₂SO₄ pretreated soybean hulls (ambient temperature treatment with 1N H₂SO₄ using 5% soybean hulls slurry for 24 h), and NaOH pretreated soybean hulls (ambient temperature treatment with 1N HCl using 5% soybean hulls slurry for 24 h) is shown in Fig. 3A-E (notice the five peaks corresponding to identified lattice planes). Almost all diffractograms using this scheme had R²>0.95. For more details on pretreatment, readers are directed to Brijwani and Vadlani (2010). As seen from Fig. 1A-E, the gradual evolution of the 002 plane (2 θ ~ 22°) from native soybean hulls to pretreated hulls is an indication of increased crystallinity in pretreated solids. The pretreated soybean hulls had crystallinity in the range of 57 to 59% compared to untreated native soybean hulls that had 42% crystallinity. The increase is probably due to reduction in the amorphous phase and plausible correction in lattice defects of cellulose during ambient-temperature acid and alkali treatments and steam treatment (Brijwani, 2011). In a similar fashion pretreated substrates were more porous compared to native soybean hulls. The increase in bed porosity is likely due to modification of the internal structure of soybean hulls that led to redistribution and partial solubilization of hemicellulose and swelling of the biomass (Kumar et al., 2009). Volumetric specific surface (cm⁻¹), on the other hand, was similar for pretreated and native soybean hulls. It should be noted that volumetric specific surface measurements were the outcome of particle size analysis done on dried substrates without any moisture addition to facilitate efficient sieving. Hence, the volumetric specific surface was more of a function of particle size and, therefore, was exclusively the representation of external surface area per unit volume. It, however, could not be the real representation of internal surface area that is the function of pore size and internal volume. The reason for showing volumetric specific surface in the current study is to identify research directions such that studying pore volume alongside porosity might provide more insight into the dynamics of cellulolytic enzyme production and its relationship with physical properties of the substrate (Brijwani, 2011).

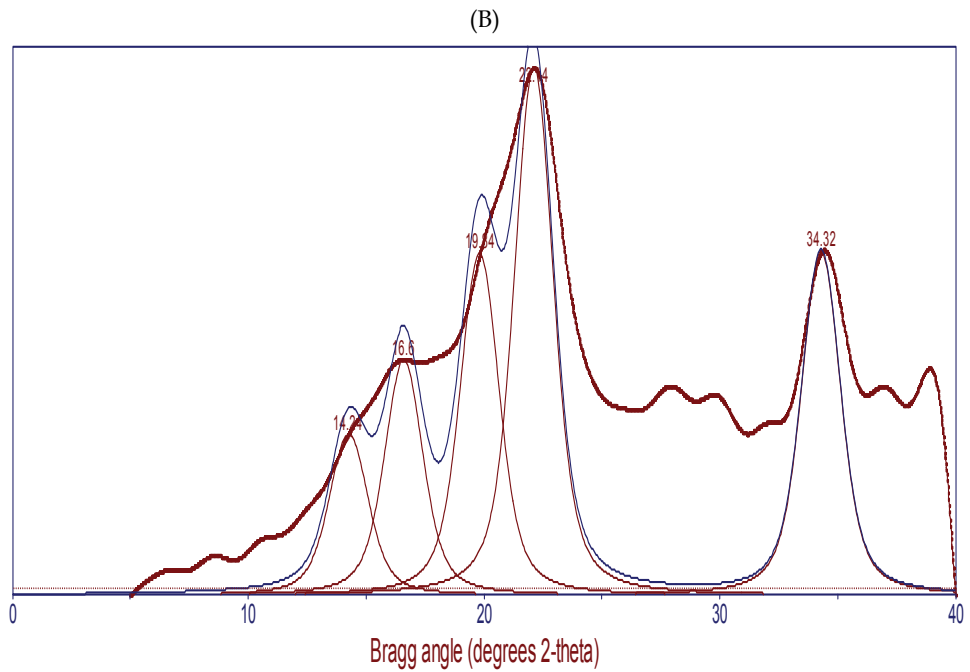
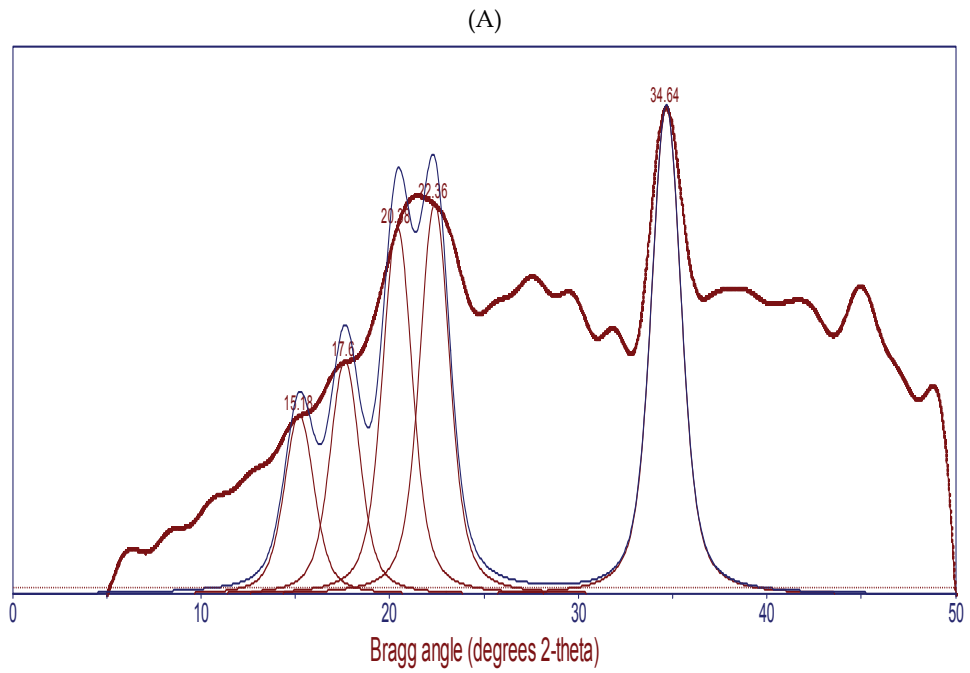

(C)

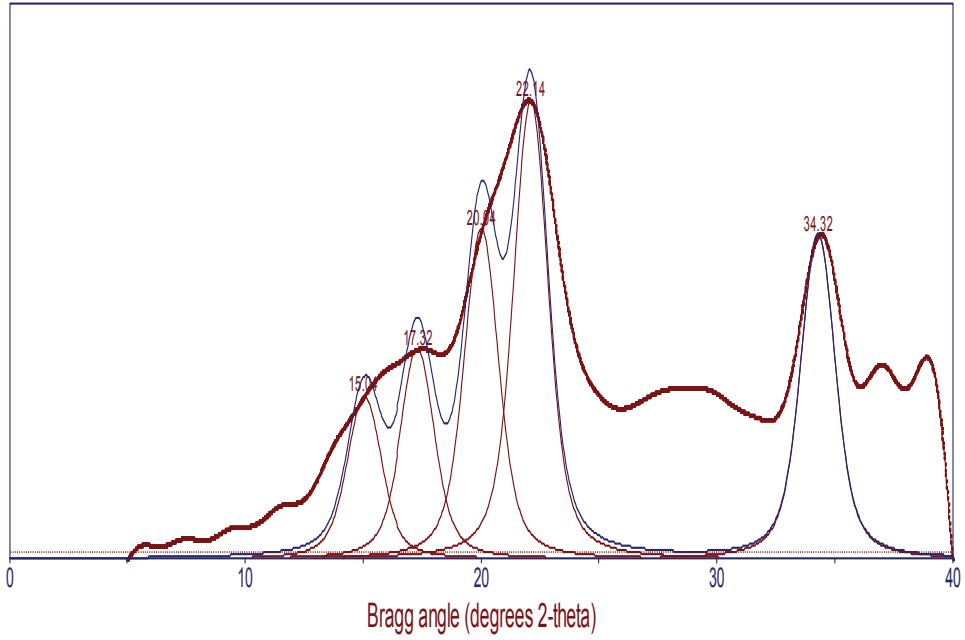

(D)

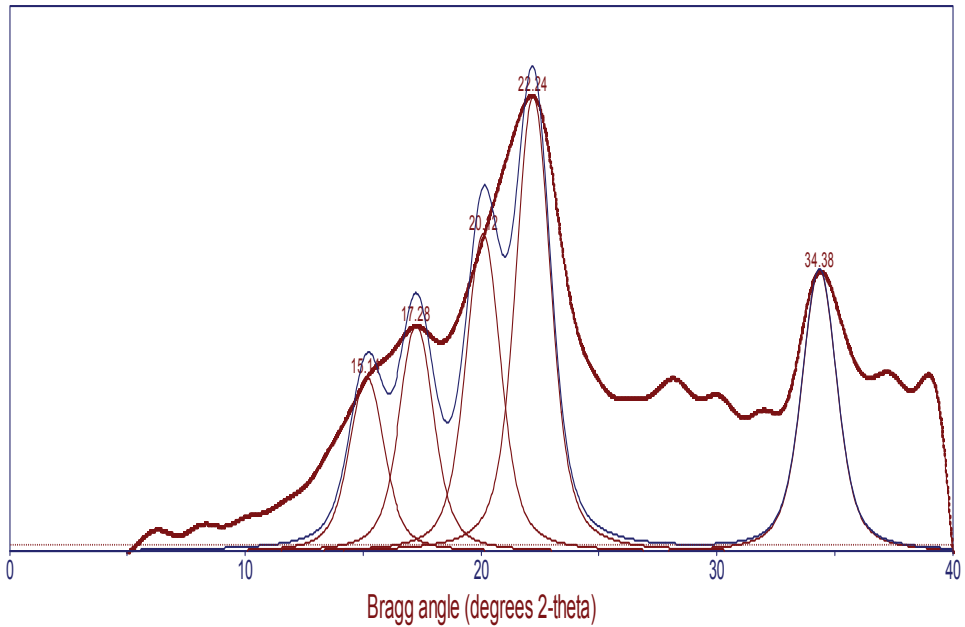

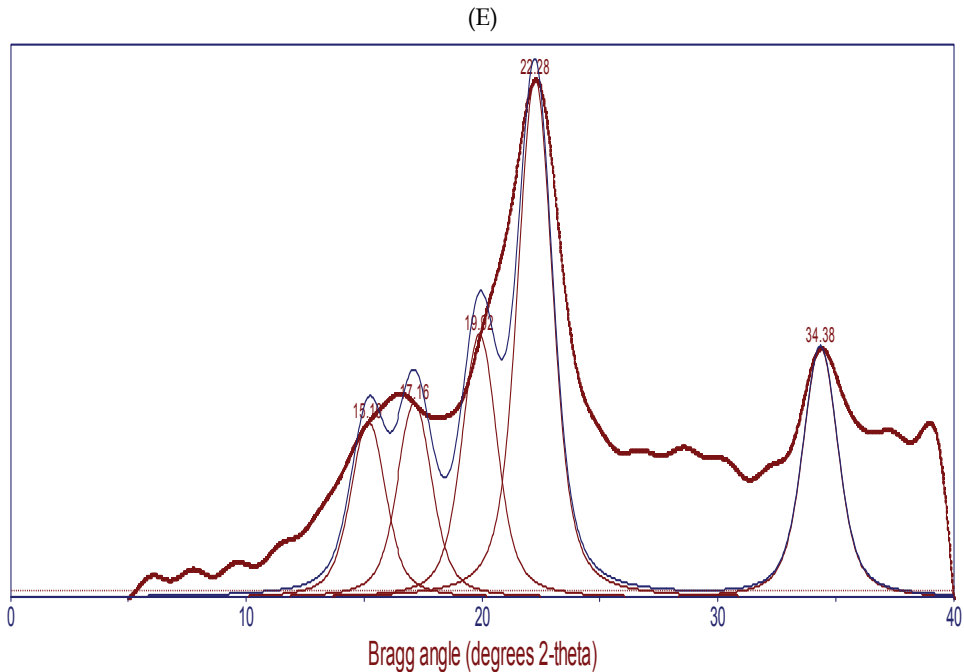

Fig. 3. X-ray Signatures. Gaussian smoothing followed by Voigt function was used to fit the diffractogram output of the instrument. (A) Native soybean hulls. The characteristics peaks identified were: $2\theta = 15.18^\circ$ (101 plane), 17.6° ($10\bar{1}$), 20.38° (021 plane), 22.36° (002 plane), and 34.64° (040 plane). (B) Steam treated soybean hulls. The characteristics peaks identified were: $2\theta = 14.24^\circ$ (101 plane), 16.6° ($10\bar{1}$), 19.84° (021 plane), 22.14° (002 plane), and 34.32° (040 plane). (C) HCl treated soybean hulls. The characteristics peaks identified were: $2\theta = 15.04^\circ$ (101 plane), 17.32° ($10\bar{1}$), 20.12° (021 plane), 22.24° (002 plane), and 34.38° (040 plane). (D) H_2SO_4 treated soybean hulls. The characteristics peaks identified were: $2\theta = 15.11^\circ$ (101 plane), 17.28° ($10\bar{1}$), 20.04° (021 plane), 22.14° (002 plane), and 34.32° (040 plane). (E) NaOH treated soybean hulls. The characteristics peaks identified were: $2\theta = 15.18^\circ$ (101 plane), 17.16° ($10\bar{1}$), 19.92° (021 plane), 22.28° (002 plane), and 34.38° (040 plane).

4.3 Effect of physicochemical characteristics on cellulolytic enzyme production in mixed and mono cultures of *T. reesei* and *A. oryzae*

In order to explicitly demonstrate the effect of crystallinity and bed porosity on cellulolytic enzyme production, we modeled both crystallinity and porosity using the general linear model of SAS with the following expression:

$$y_{ijk} = \mu + ab_{ij} + \epsilon_{ijk} \quad (7)$$

Where y_{ijk} is one of the enzyme activities as the dependent variable, μ is the grand mean, ab_{ij} is the interaction effect of crystallinity and porosity, and ϵ_{ijk} is random error with mean 0 and experimental error variance as its variance. The composition was not included as it

was fairly constant across treatments i.e., the total cellulosic composition (cellulose + hemicellulose) was not significantly different among the pretreatments (Brijwani, 2011). This was attributed to mild nature of the pretreatments. Similarly, volumetric specific surface was not included in the model as it did not change significantly upon pretreatment. Considering crystallinity and porosity together became necessary because of availability of a reduced number of degrees of freedom that refrained their independent analysis. It was very difficult to generate substrates for which one effect was varied while the other effect remained constant. Future studies in this direction will be beneficial, provided such substrates are available or easy to generate. Broadly speaking, the model represented by equation (7) is more reflective of one-way variance analysis than factorial variance analysis. On the basis of results in Table 1, both crystallinity and porosity had positive and significant improvements in all enzyme activities except xylanase production for *T. reesei*. Notice that only native and steam-treated soybean hulls were included in determining out the

| Interaction | Culture | Cellulolytic enzyme system | | | | Treatments considered |
|--------------------------|---------------------------|-------------------------------|----------------------------|-------------------------|--------------------|--|
| | | Filter paper units (FPU/g-ds) | Beta-glucosidase (IU/g-ds) | Endoglucanase (IU/g-ds) | Xylanase (IU/g-ds) | |
| Crystallinity × Porosity | <i>Trichoderma reesei</i> | <0.0001* | 0.0388* | <0.0001* | 0.0472 | Native, Steam |
| Crystallinity × Porosity | <i>Aspergillus oryzae</i> | <0.0001* | 0.2736 | <0.0001* | 0.0065* | Native, Steam, HCl, H ₂ SO ₄ |
| Crystallinity × Porosity | <i>Aspergillus oryzae</i> | 0.4629 | 0.9218 | 0.0005* | 0.9912 | Native, Steam |
| Crystallinity × porosity | Mixed | <0.0001* | 0.0140* | <0.0001* | <0.0001* | Native, Steam, HCl, H ₂ SO ₄ |
| Crystallinity × porosity | Mixed | 0.0044* | 0.0449 | 0.0257* | 0.9061 | Native, Steam |

“*” indicates probability for a particular interaction is significant at 95% confidence Abbreviations

Native: - Untreated soybean hulls

Steam: - Steam-pretreated soybean hulls

HCl: - Soybean hulls pretreated with 1N HCl

H₂SO₄: - Soybean hulls pretreated with 1N H₂SO₄

NaOH: - Soybean hulls pretreated with 1N NaOH

Table 1. Effect of interaction between physical characteristics on production of cellulolytic enzyme system for three cultures

differences. This was a result of the higher sensitivity of *T. reesei* toward inhibitors present in acid- and alkali-treated substrates. In *A. oryzae*, when all four substrates were considered, we noticed that probabilities were significant in all cases. In general, acid-pretreated substrates, except in β -glucosidase production, performed lower than native and steam-pretreated substrates, which is probably the reason for the lower probabilities. Therefore, when acid substrates were removed from the model, the real effect of crystallinity and porosity on production of endocellulase became evident, and the effect increased significantly with increases in crystallinity and porosity. In mixed culture (Table 1), the effect was more or less level, and performance was nearly identical except that filter paper and beta-glucosidase activities were significantly higher in less crystalline and porous native soybean hulls than in highly crystalline and porous steam-treated soybean hulls.

Porosity is a physical parameter that ensures oxygen availability between the moist substrate particles. It is plausibly implicated in the growth of fungal cultures and, therefore, affects enzyme production from a growth point of view. Rahardjo et al. (2005a; 2005b) explained this phenomenon by using different kinds of model substrates that differed in the amount of open spaces for production of α -amylase in solid-state cultures of *A. oryzae*. Crystallinity, on the other hand, might be the decisive factor in influencing expression levels of enzymes within a cellulolytic enzyme system, suggesting it might enrich one activity over another. This phenomenon was noticed in *T. reesei*, in which production of cellulase enzymes increased substantially in pretreated soybean hulls compared with native hulls but xylanase remained constant. We made similar observations in endocellulase production in *A. oryzae*. A positive effect of crystallinity was also reported for liquid cultures of *Trichoderma* spp. (Acebal et al., 1986; Evans et al., 1992; Aiello et al., 1996). Although no specific variation in different activities with varying crystallinity were mentioned in these studies, an overall increase in cellulase activity was reported during growth on pretreated crystalline biomass or standard crystalline cellulose.

5. Conclusions

The present study demonstrated for the first time the suitability of mixed-culture, solid-state fermentation in the production of an efficient cellulase enzymes complex from soybean hulls. Further, the role of physicochemical characteristics in production of cellulolytic enzymes in fungal SSF was comprehensively investigated. With recent advances in computation capability, whole X-ray diffractograms can be fitted to obtain reliable measures of crystallinity of heterogeneous material such as lignocellulosic biomass. Production of cellulase enzyme using co-cultures of *T. reesei* and *A. oryzae* grown on solid media containing 4:1 of soybean hulls and wheat bran were fitted to quadratic model using RSM. Both cellulase and β -glucosidase production showed significant dependence on temperature and moisture content as compared to pH. Temperature showed quadratic effect on the production of both cellulase and β -glucosidase while moisture had linear effect on cellulase and β -glucosidase production. The interaction effects of three independent variables were not significant though interaction of temperature and moisture was considerable for cellulase production, while interaction of moisture and pH was considerable for β -glucosidase production. The optimized values of three independent variables viz. temperature, pH and moisture content were predicted using numerical optimization that maximized cellulase and β -glucosidase activities. Results showed that co-culturing of fungal

species with proper optimization resulted in complete and balanced production of enzymes. Both bed porosity and crystallinity were significantly implicated in production of cellulolytic enzymes. We explicitly showed that exposure of crystallinity made *T. reesei* a robust producer of cellulolytic enzymes, whereas *A. oryzae* responded to crystallinity by being a good producer of endocellulase activity. The changes brought about by physical characteristics are an important design tool for process development of the SSF. By changing the physical attributes expression levels of enzymes can be varied such that physicochemical characteristics become the leading force in directing synthesis of the cellulolytic enzyme system in SSF.

6. Acknowledgements

The authors are grateful to the Center for Sustainable Energy and the Department of Grain Science and Industry, Kansas State University, for funding this project. This article is contribution no 11-079-B from the Kansas Agricultural Experiment Station, Manhattan, KS 66506.

7. References

- Acebal C, Castillon MP, Estrada P, Mata I, Costa E, Aguado J, Romero D, Jimenez F. Enhanced cellulase production from *Trichoderma reesei* QM 9414 on physically treated wheat straw. *Appl Microbiol Biotechnol* 1986;24:218-223.
- Aguilar G, Huitron C. Application of fed-batch treatments in the production of extracellular pectinases by *Aspergillus* sp. *Enzyme Microb Technol* 1986;8:541-545.
- Aiello C, Ferrer A, Ledesma A. Effect of alkaline treatments at various temperatures on cellulase and biomass production using submerged sugarcane bagasse fermentation with *Trichoderma reesei* QM 9414. *Bioresource Technol* 1996;57:13-18.
- Archana A, Satyanarayana T. Xylanase production by thermophilic *Bacillus licheniformis* A99 in solid state fermentation. *Enzyme Microb Technol* 1997;8:541-545
- Aro N, Pakula T, Penttila M. Transcriptional regulation of plant cell wall degradation by filamentous fungi. *Fems Microbiol Rev* 2005;29:719-739.
- Bisaria VS, Mishra S. Regulatory aspects of cellulase biosynthesis and secretion. *Crit Rev Biotechnol* 1989;9:61-103.
- Botella C, Diaz AB, Wang RH, Koutinas A, Webb C. Particulate bioprocessing: A novel process strategy for biorefineries. *Process Biochem* 2009;44:546-555.
- Brijwani K, Oberoi HS, Vadlani PV. Production of cellulolytic enzyme system in mixed-culture solid-state fermentation of soybean hulls supplemented with wheat bran. *Process Biochem* 2010;45:120-128.
- Brijwani K. Solid state fermentation of soybean hulls for cellulolytic enzyme production: Physicochemical characteristics of substrate, and bioreactor design and modeling. PhD Dissertation, Department of Grain Science & Industry, Kansas State University, 2011
- Cen P, Xia L. Production of cellulase in solid state fermentation. In: Scheper T, editor. *Recent progress in bioconversion of lignocellulosics*. *Advances in Biochemical Engineering/Biotechnology*. vol. 65. Berlin: Springer; 1999. p. 69.
- Chahal DS, McGuire S, Pikor H, Noble G. Production of cellulase complex by *Trichoderma reesei* RUT-C30 on lignocellulose and its hydrolytic potential. *Biomass* 1982;2:127-138.

- Duff SJB, Cooper DG, Fuller OM. Effect of media composition and growth conditions on production of cellulase and β -glucosidase by a mixed fungal fermentation. *Enzyme Microb Technol* 1987;9:47-52
- Esterbauer H, Steiner W, Labudova I, et al. Production of *Trichoderma* cellulase in laboratory and pilot scale. *Bioresource Technol* 1991;36:51-65.
- Evans ET, Wales DS, Bratt RP, Sagar BF. Investigation of an endoglucanase essential for the action of the cellulase system of *Trichoderma reesei* on crystalline cellulose. *J Gen Microbiol* 1992;138:1639-1646.
- Garvey CJ, Parker IH, Simon GP. On the interpretation of X-ray diffraction powder patterns in terms of the nanostructure of cellulose I fibres. *Macromol Chem Phys* 2005;206:1568-1575.
- Giovanni M. Response surface methodology and product optimization. *Food Technol* 1983;37:41-45, 83
- Grajek W. Hyperproduction of thermostable beta-glucosidase by *Sporotrichum (Chrysosporium)* thermophile. *Enzyme Microb Technol* 1987;9:744-748
- Holker U, Hofer M, Lenz J. Biotechnological advantages of laboratory scale solid state fermentation with fungi. *Appl Microbiol Biotechnol* 2004;64:175-186.
- Hounsa CG, Aubry JM, Dubourguier HC. Application of factorial and Doehlert designs for optimization of pectate lyase production by a recombinant *Escherichia coli*. *App Microbiol Biotechnol* 1996;45:764-770
- Kasai N, Kakudo M. X-ray diffraction by macromolecules. New York: Springer; 2005.p.504
- Krishna C. Solid state fermentation systems: An overview. *Crit Rev Biotechnol* 2005;25:1-30.
- Kumar P, Barrett DM, Delwiche MJ, Stroeve P. Methods for Pretreatment of Lignocellulosic Biomass for Efficient Hydrolysis and Biofuel Production. *Ind Eng Chem Res* 2009;48:3713-3729.
- Latifian M, Hamidi- Esphaini Z, Barzegar M. Evaluation of culture conditions for cellulase production by two *Trichoderma reesei* mutants under solid-state fermentation conditions. *Bioresour Technol* 2007;98:3634-3637
- Liu BL, Tzeng YM. Optimization of growth medium for the production of spores from *Bacillus thuringiensis* using response surface methodology. *Bioprocess Biosystem Eng* 1998;18:413-418
- Liu RG, Yu H, Huang Y. Structure and morphology of cellulose in wheat straw. *Cellulose* 2005;12:25-34.
- Mach RL, Zeilinger S. Regulation of gene expression in industrial fungi: *Trichoderma*. *Appl Microbiol Biotechnol* 2003;60:515-522.
- Maddox IS, Richer SH. Use of response surface methodology for rapid optimization of microbiological media. *J App Bacteriol* 1977;43:197-204
- Mandels M, Medeiros JE, Andreotti RE, Bisset FH. Enzymatic hydrolysis of cellulose- effect of physicochemical properties of cellulose on adsorption and rate of hydrolysis. *Biotechnol Bioeng* 1981;23:2009-2026.
- Marshall WE, Wartelle LH. Acid recycling to optimize citric acid-modified soybean hull production. *Ind Crop Prod* 2003;18:177-182.
- Mes-Hartree M, Hogan CM, Saddler JN. Influence of growth substrate on production of cellulase enzymes by *Trichoderma harzianum* E58. *Biotechnol Bioeng* 1988;31:725-729.
- Mielenz JR, Bardsley JS, Wyman CE. Fermentation of soybean hulls to ethanol while preserving protein value. *Bioresource Technol* 2009;100:3532-3539.

- Oostra J, le Comte EP, van den Heuvel JC, Tramper J, Rinzema A. Intra-particle oxygen diffusion limitation in solid-state fermentation. *Biotechnol Bioeng* 2001;75:13-24.
- Rahardjo YSP, Jolink F, Haemers S, Tramper J, Rinzema A. Significance of bed porosity, bran and specific surface area in solid-state cultivation of *Aspergillus oryzae*. *Biomol Eng* 2005a;22:133-139.
- Rahardjo YSP, Weber FJ, Haemers S, Tramper J, Rinzema A. Aerial mycelia of *Aspergillus oryzae* accelerate alpha-amylase production in a model solid-state fermentation system. *Enzyme Microb Technol* 2005;36:900-902.
- Rietveld HM. A profile refinement method for nuclear and magnetic structures. *J Appl Cryst* 1969;2:65-71.
- Rietveld HM. Line profiles of neutron powder-diffraction peaks for structure refinement. *Acta Cryst* 1967;22:151-152.
- Ruland W. X-RAY determination of crystallinity and diffuse disorder scattering. *Acta Cryst* 1961;14:1180-1185.
- Segal L, Creely JJ, Martin AE, Conrad CM. An empirical method for estimating the degree of crystallinity of native cellulose using X-ray diffractometer. *Tex Res J* 1959;29:786-794.
- Singhania RR, Sukumaran RK, Pandey A. Improved cellulase production by *Trichoderma reesei* RUT C30 under SSF through process optimization. *Appl Biochem Biotechnol* 2007;142:60-70
- Siqueira EMD, Mizuta K, Giglio JR. *Pycnoporus sanguineus*: a novel source of alpha-amylase. *Mycol Res* 1997;101:188-190
- Solis-Pereyra S, Favela-Torres E, Gutierrez-Rojas M et al. Production of pectinase by *Aspergillus niger* in solid state fermentation at high initial glucose concentrations. *World J Microbiol Biotechnol* 1996;12:257-260
- Stockton BC, Mitchell DJ, Grohmann K, et al. Optimum β -D glucosidase supplementation of cellulase for efficient conversion of cellulose to glucose. *Biotechnology Lett* 1991;13:57-62.
- Taupin D. Powder-diagram automatic-indexing routine. *J Appl Cryst* 1973;6:380-385.
- Theodore K, Panda, T. Application of response surface methodology to evaluate the influence of temperature and initial pH on the production of beta-1,3-glucanase and carboxymethylcellulase from *Trichoderma harzianum*. *Enzyme Micro Technol* 1995;17:1043-1049
- Thibault J, Pouliot K, Agosin E, Perez-Correa R. Reassessment of the estimation of dissolved oxygen concentration profile and K_{La} in solid-state fermentation. *Process Biochem* 2000;36:9-18.
- Thygesen A, Oddershede J, Lilholt H, Thomsen AB, Stahl K. On the determination of crystallinity and cellulose content in plant fibres. *Cellulose* 2005;12:563-576.
- Vonk CG. Computerization of Rulands x-ray method for determination of crystallinity in polymers. *J Appl Cryst* 1973;6:148-152.
- Wada M, Okano T, Sugiyama J. Synchrotron-radiated X-ray and neutron diffraction study of native cellulose. *Cellulose* 1997;4:221-232.

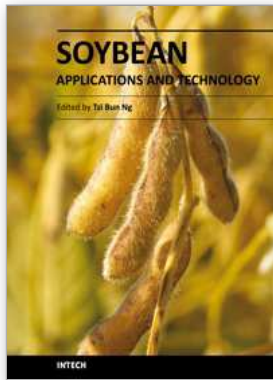

Soybean - Applications and Technology

Edited by Prof. Tzi-Bun Ng

ISBN 978-953-307-207-4

Hard cover, 402 pages

Publisher InTech

Published online 26, April, 2011

Published in print edition April, 2011

Soybean is an agricultural crop of tremendous economic importance. Soybean and food items derived from it form dietary components of numerous people, especially those living in the Orient. The health benefits of soybean have attracted the attention of nutritionists as well as common people.

How to reference

In order to correctly reference this scholarly work, feel free to copy and paste the following:

Khushal Brijwani and Praveen V. Vadlani (2011). Solid State Fermentation of Soybean Hulls for Cellulolytic Enzymes Production, Soybean - Applications and Technology, Prof. Tzi-Bun Ng (Ed.), ISBN: 978-953-307-207-4, InTech, Available from: <http://www.intechopen.com/books/soybean-applications-and-technology/solid-state-fermentation-of-soybean-hulls-for-cellulolytic-enzymes-production>

INTECH

open science | open minds

InTech Europe

University Campus STeP Ri
Slavka Krautzeka 83/A
51000 Rijeka, Croatia
Phone: +385 (51) 770 447
Fax: +385 (51) 686 166
www.intechopen.com

InTech China

Unit 405, Office Block, Hotel Equatorial Shanghai
No.65, Yan An Road (West), Shanghai, 200040, China
中国上海市延安西路65号上海国际贵都大饭店办公楼405单元
Phone: +86-21-62489820
Fax: +86-21-62489821

© 2011 The Author(s). Licensee IntechOpen. This chapter is distributed under the terms of the [Creative Commons Attribution-NonCommercial-ShareAlike-3.0 License](#), which permits use, distribution and reproduction for non-commercial purposes, provided the original is properly cited and derivative works building on this content are distributed under the same license.

Immunoquantitative Measurement of Soybean Aeroallergen Emissions

María-Jesús Cruz and Susana Gómez-Ollés
*Respiratory Department. Hospital Vall d'Hebron. Barcelona
Spain*

1. Introduction

Environmental allergen exposure plays an important role in the development and expression of asthma and allergy. To study allergen exposure, it is necessary to actually measure allergen levels. Direct measurement is also needed to assess what levels lead to sensitisation or provoke symptoms in already sensitised subjects, and evaluate the efficacy of allergy reduction strategies (1). The measurement of aeroallergens plays a key role in asthma prevention.

Both the epidemiological studies and the studies on specific IgE to soybean carried out following the asthma epidemics in Barcelona attributed their cause to the unloading of soybean in the harbour (2-3). The environmental intervention in September 1987 with the installation of bag filters in a silo led to a decrease in airborne soybean concentrations and the subsequent disappearance of the epidemics (4). The 1,555 U/m³ level of soybean allergen detected during a determined asthma epidemic day (5-6) was substantially higher than the highest value (165 U/m³) recorded in 22 unloading days after the interventions (4). These data show that the measurement of soybean aeroallergen levels in harbours loading and unloading soybean is of increasing importance in controlling the efficiency of the environmental interventions in order to prevent new asthma outbreaks in these areas.

In the evaluation of occupational asthma, measurement of the causal agent in the air at worksites is a necessary additional link in the chain of evidence that a suspected allergen is the cause of the pathology. Such measurements are particularly useful when the allergen is unknown, the environment of interest has never before been assessed, and control measures have to be considered. Knowledge of the concentration at work also allows correlation between exposure of workers and an inhalation challenge test in the laboratory, which is performed in individual patients to confirm that the suspected allergenic material that evoked the IgE antibody can actually cause an asthmatic response (7). Thus, it is of great interest to monitor soybean dust levels indoors.

2. Soybean aeroallergens

2.1 Epidemic asthma allergens

Investigation of the epidemics in the city of Barcelona revealed that the outbreaks were caused by soybean dust generated by unloading of soybeans in the harbour on days when the wind carried the soybean dust over the city (2-3, 8). Rodrigo et al. (8) demonstrated that during an epidemic the serum of patients with asthma reacted specifically to an acidic, low-

molecular mass (LMM) protein (<14 kDa) located principally in hulls and dust of soybeans unloaded in the harbour. Two proteins located in soybean hulls were later shown to be the main allergens responsible for this asthma epidemic (9). Both proteins are isoallergens (Gly m 1a and Gly m 1b) with molecular weights of 7.0 and 7.5 kDa, respectively, and are highly homologous with the hydrophobic soybean protein (HSP) described by Odani et al. (10).

2.2 Occupational asthma allergens

Exposure to soybean dust and flour has been reported to cause occupational allergic asthma in persons working in a variety of occupations, such as farmers, mill workers, soybean handlers and bakers (11-19).

It has been established that the allergens responsible for occupational asthma in bakers exposed to soy flour are not the same as those involved in soy dust-induced asthma epidemics, and the proteins causing both these conditions may differ from those involved in cases of adverse reactions following oral ingestion of soy (19). The low-molecular weight (LMW) soybean hull proteins (8, 20), Gly m 1 (9, 21) and Gly m 2 (22) have been identified as the main allergens that cause the asthma outbreaks, while allergens responsible for soybean flour-induced occupational asthma would be mainly high-molecular weight (HMW) proteins (17, 19). Soy hull components may, however, also have been involved in occupational asthma reported in animal feed manufacturers (23). Thus, 'soy aeroallergen exposure' might vary markedly between worksites.

In 1988 a study was performed to characterize the allergens involved in a food-processing worker's IgE-mediated response to soybean flour (15). Nine proteins were recognised, with molecular weights ranging from 54.5 to 14.9 kDa (15). Reactivity to soybean flour was also observed in a study performed by Alvarez et al (24) in 9 of 21 cereal workers. Therefore, the allergens involved in occupational asthma may differ from the causative agents in the Barcelona epidemics.

3. Methods for immunoquantitative measurement of soybean aeroallergen

For monitoring aeroallergens it is indispensable to have simple and reliable techniques. Morphologically identifiable allergenic particles such as pollen grains can be quantified by appropriate air sampling techniques and counting microscopically. Viable particles such as mould spores can be cultured quantitatively. Chemical assays for LMW substances such as diisocyanates have been invaluable in monitoring the environment for efficacy of control measures assigned to reduce exposure (25). But many allergens are amorphous, non-viable particles that cannot be quantified by these methods. Thus, the current means for objectively quantifying airborne allergens levels is air sampling on filter, elution of the allergens from the filter, and measurement of allergen concentration in the eluate by specific immunoassays.

Several different immunological methods have been used to measure occupational and environmental allergens, with the Radio Allergo Sorbent Test (RAST) and Enzyme Linked Immunoabsorbent Assay (ELISA)-inhibition being the most used. However, ELISA has replaced the RAST in many laboratories, as it offers comparable sensitivity without the problems of disposal and the short half-life associated with radioactive materials. Immunoassays measure allergen levels in samples by using antibodies directed against the allergens. The antibodies may be derived from pooled sera from sensitised patients or from experimentally sensitised animals. The latter can be either polyclonal antibodies that recognise a range of epitopes, or monoclonal antibodies, consisting of one clone of a specific antibody. Sandwich or inhibition assay set-ups can be utilised (1).

Specific human IgE is theoretically the ideal antibody, since, by definition, it only detects the allergen to be measured (26). However, an obvious disadvantage of assays using human IgE antibody is the limited availability of suitable sera and the occupational health risk associated with the handling of human blood samples. Availability is even poorer because of the low absolute titres; at times nearly undiluted sera must be used for the IgE inhibition assays. Moreover, IgE inhibition methods are frequently considered semiquantitative assays with potential long-term reproducibility problems because of the use of heterogeneous antibody pools (27). Furthermore, testing by different laboratories using their own serum pools may be subject to inter-laboratory and possibly inter-batch differences in allergen recognition profiles (28). This makes comparison of absolute measurements of airborne allergens among different studies difficult (29). Due to those limitations other assays have been developed.

3.1 Monitoring soy aeroallergens causing epidemic asthma

To monitor soy aeroallergens in the city of Barcelona, samples are obtained by large-volume automated air samplers containing glass microfiber filters with a 1 μm pore size of. In October 1986, two samplers were installed in highly populated areas of the city where many epidemic cases had been identified (5). Further studies were centred on results obtained from the municipal atmospheric contamination control station located in the port authority customs building. This station was closest to the soy processing plants and to neighbourhoods with the largest number of affected patients (30). Allergens were extracted from the filters and immunochemically assayed. Measurements from sampling filters yield a 24 hour average.

Some immunoassays have been described for quantifying airborne levels of the LMW soy allergens (20, 31-32). A human IgE ELISA-inhibition method is currently used for daily monitoring of the soy hull LMW (SHLMW) aeroallergens in the city of Barcelona (31) (Figure 1A). The amplified ELISA inhibition method use as antigen and reference preparation a SHLMM extract which contains proteins with a molecular weight lower than 10 kDa and as primary antibody a pool of human sera. This method is useful for soybean monitoring but, has the drawbacks of using human antibodies and being an inhibition method.

Because the widespread use of human sera in these assays is complicated by their limited availability and a relatively low sensitivity, other assays have been developed, such as the monoclonal antibody based method to quantify Gly m 1 (32). However, the high specificity of a monoclonal antibody-based ELISA - depending on the recognition of a single epitope - could also be a disadvantage if in some soy dust mixtures the epitope is masked and the actual allergen exposure level is thus underestimated (33). Therefore recently was also developed a polyclonal rabbit IgG-based assay for soy hull antigens. Gomez-Olles et al (34) describes an 'amplified ELISA', that combines a high sensitivity with reasonably high specificity while avoiding the risk of false-negatives associated with the use of monoclonal antibodies (Figure 1B). There are positive advantages of using polyclonals, e.g. cheaper and easier, the polyclonal method is less disturbed by epitope losses, several allergens may be present that can be detected and polyclonal methods can be made very sensitive.

3.2 Monitoring soy aeroallergens causing occupational asthma

Epidemiologic studies suggest that in addition to genetic and other factors related to individual susceptibility, one determinant of the prevalence of occupational asthma is the level of exposure to a workplace sensitizer (35).

Since the introduction of immunochemical techniques, a considerable number of exposure studies have been performed in a wide range of occupational settings. Allergen exposure has been assessed for enzymes such as papain in the meat processing industry, fungal α -

amylase in the baking industry, egg protein, pig and cow urinary and dander proteins in agriculture, wheat allergens, and rat and mouse urinary allergens (26). The first reports of soy allergy were occupation-related and occurred in soybean mill workers (11).

To evaluate differences in quality and quantity of soy aeroallergens among different worksites and assess the suitability of different immunoassays to measure workplace soy aeroallergens levels, a large series of airborne samples were collected in three European countries in soy plants, animal feed industries and in pig farms (36). Samples were either analysed for airborne soy allergen by five ELISAs with different specificity and/or sensitivity. Comparison of allergen levels measured by the different ELISAs showed a very strong correlation between several of the methods. Nevertheless, some differences were found between some of these methods. These differences can be attributed in part to differences in the specificities of antibodies and allergen standards, as found in other studies where differences in antibody specificities accounted for up to 800-fold differences (37).

Reported soy aeroallergen levels also depended strongly on the sampling site. In addition, the relative ranking of exposure levels in various work environments depended in the ELISA applied, and this could also be ascribed to the different specificities of the methods. Thus, the data strongly suggest that airborne samples from different work environments with 'soy exposure' may contain 'soy dust' with quite different composition. For example, soy hull antigens are more commonly found at sites where whole soybeans are unloaded and stored, such as at the harbour silos in Barcelona (8,9), whereas in a work environment where processed soybean and flours are used, such as feed and food industries, the airborne soy proteins maybe mainly soy flour-derived. Differences in soy allergen composition of airborne samples and differences in ELISA antibody specificity might also explain the very low correlations between some of the assays.

Thus, no unambiguous answer can be given to the question regarding the optimal procedure for assessment of airborne soy allergen exposure. In addition to the sensitivity, specificity and reproducibility of the assays and the availability of reagents, the work environment that is going to be evaluated should be considered.

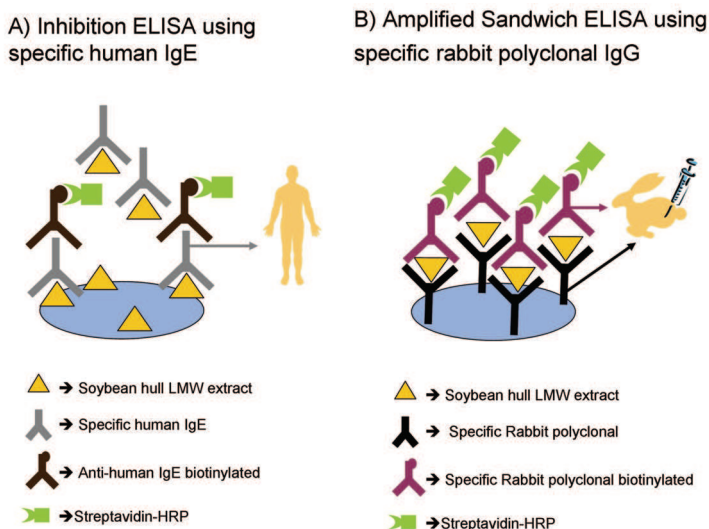
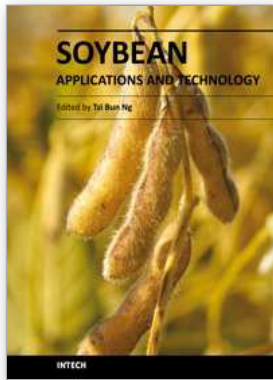

Fig. 1.

4. References

- [1] Renstrom A. Exposure to airborne allergens: A review of sampling methods. *J Environ Monit* 2002;4(5):619-22.
- [2] Anto JM, Sunyer J, Rodriguez-Roisin R, Suarez-Cervera M, Vazquez L. Community outbreaks of asthma associated with inhalation of soybean dust. Toxicoepidemiological committee. *N Engl J Med* 1989;320(17):1097-102.
- [3] Sunyer J, Anto JM, Rodrigo MJ, Morell F. Case-control study of serum immunoglobulin-E antibodies reactive with soybean in epidemic asthma. *Lancet* 1989;1:179-82.
- [4] Anto JM, Sunyer J, Reed CE, Sabria J, Martinez F, Morell F, et al. Preventing asthma epidemics due to soybeans by dust-control measures. *N Engl J Med* 1993;329(24):1760-3.
- [5] Aceves M, Grimalt JO, Sunyer J, Anto JM, Reed CE. Identification of soybean dust as an epidemic asthma agent in urban areas by molecular marker and RAST analysis of aerosols. *J Allergy Clin Immunol* 1991;88(1):124-34.
- [6] Soriano JB, Anto JM, Plasencia A, and the Barcelona Soybean-Asthma Group. Repeaters count: A sentinel method for asthma outbreaks. *Thorax* 1995;50(10):1101-3.
- [7] Swanson MC, Heederik D. Quantification of Bio-Active Protein Aerosols. In: Bernstein IL, Chan-Yeung M, Malo JL, Bernstein DI eds. *Asthma in the workplace*, 3rd edition. New York: Taylor and Francis, 2006: 275-96.
- [8] Rodrigo MJ, Morell F, Helm RM, Swanson M, Greife A, Anto JM, et al. Identification and partial characterization of the soybean-dust allergens involved in the Barcelona asthma epidemic. *J Allergy Clin Immunol* 1990;85(4):778-84.
- [9] Gonzalez R, Varela J, Carreira J, Polo F. Soybean hydrophobic protein and soybean hull allergy. *Lancet* 1995;346:48-9.
- [10] Odani S, Koide T, Ono T, Seto Y, Tanaka T. Soybean hydrophobic protein: Isolation, partial characterization and the complete primary structure. *Eur J Biochem* 1987;162(3):485-91.
- [11] Duke WW. Soybean as a possible important source of allergy. *Allergy* 1934;5:300-2.
- [12] Bush RK, Cohen M. Immediate and late onset asthma from occupational exposure to soybean dust. *Clin Allergy* 1977;7(4):369-73.
- [13] Bourgeois M. Asthme sévère par inhalation de poussière de soja. *Rev Fr Allergol* 1984;24(4):209-10.
- [14] Pepys J. Occupational allergic lung disease caused by organic agents. *J Allergy Clin Immunol* 1986;78(5 pt 2):1058-62.
- [15] Bush RK, Schroeckenstein D, Meier-Davis S, Balmes J, Rempel D. Soybean flour asthma: Detection of allergens by immunoblotting. *J Allergy Clin Immunol* 1988;82(2):251-5.
- [16] Baur X, Sauer W, Weiss W. Baking additives as new allergens in baker's asthma. *Respiration* 1988;54(1):70-2.
- [17] Baur X, Pau M, Czuppon A, Fruhmann G. Characterization of soybean allergens causing sensitization of occupationally exposed bakers. *Allergy* 1996;51(5):326-30.
- [18] Lavaud F, Perdu D, Prevost A, Vallerand H, Cossart C, Passemard F. Baker's asthma related to soybean lecithin exposure. *Allergy* 1994;49(3):159-62.
- [19] Quirce S, Polo F, Figueredo E, Gonzalez R, Sastre J. Occupational asthma caused by soybean flour in bakers - differences with soybean-induced epidemic asthma. *Clin Exp Allergy* 2000;30(6):839-46.
- [20] Swanson MC, Li JT, Wentz-Murtha PE, Trudeau WL, Fernandez-Caldas E, Greife A, et al. Source of the aeroallergen of soybean dust: A low molecular mass glycopeptide from the soybean tela. *J Allergy Clin Immunol* 1991;87(4):783-8.

- [21] Gonzalez R, Polo F, Zapatero L, Caravaca F, Carreira J. Purification and characterization of major inhalant allergens from soybean hulls. *Clin Exp Allergy* 1992;22(8):748-55.
- [22] Codina RM, Calderon E, Lockey RF, Fernandez-Caldas E, Rama R. Specific immunoglobulins to soybean hull allergens in soybean asthma. *Chest* 1997;111(1):75-80.
- [23] Maggio P, Monso E, Baltasar M, Morera J. Occupational asthma caused by soybean hull: A workplace equivalent to epidemic asthma. *Allergy* 2003;58(4):350-1.
- [24] Alvarez MJ, Tabar AI, Quirce S, Olaguibel JM, Lizaso MT, Echechipia S, et al. Diversity of allergens causing occupational asthma among cereal workers as demonstrated by exposure procedures. *Clin Exp Allergy* 1996;26(2):147-53.
- [25] Reed CE, Swanson MC, Agarwal MK, Yunginger JW. Allergens that cause asthma. Identification and quantification. *Chest* 1985;87(1 Suppl):40S-4S.
- [26] Heederik D, Doekes G, Nieuwenhuijsen MJ. Exposure assessment of high molecular weight sensitizers: Contribution to occupational epidemiology and disease prevention. *Occup Environ Med* 1999;56(11):735-41.
- [27] Renstrom A, Gordon S, Larsson PH, Tee RD, Newman-Taylor AJ, Malmberg P. Comparison of a radioallergosorbent (RAST) inhibition method and a monoclonal enzyme linked immunosorbent assay (ELISA) for aeroallergen measurement. *Clin Exp Allergy* 1997;27(11): 1314-21.
- [28] Bogdanovic J, Wouters IM, Sander I, Zahradnik E, Elms J, Rodrigo MJ, et al. Airborne exposure to wheat allergens: Optimised elution for airborne dust samples. *J Environ Monit* 2006;8(10):1043-8.
- [29] Gordon S, Kiernan LA, Nieuwenhuijsen MJ, Cook AD, Tee RD, Newman-Taylor AJ. Measurement of exposure to mouse urinary proteins in an epidemiological study. *Occup Environ Med* 1997;54(2):135-40.
- [30] Villalbi JR, Plasencia A, Manzanera R, Armengol R, Anto JM, Collaborative and Technical Support Groups for the study of soybean asthma in Barcelona. Epidemic soybean asthma and public health: New control systems and initial evaluation in Barcelona, 1996-98. *J Epidemiol Community Health* 2004;58(6):461-5.
- [31] Cruz MJ, Rodrigo MJ, Anto JM, Morell F. An amplified ELISA inhibition method for the measurement of airborne soybean allergens. *Int Arch Allergy Immunol* 2000;122(1):42-8.
- [32] Gonzalez R, Duffort O, Calabozo B, Barber D, Carreira J, Polo F. Monoclonal antibody-based method to quantify Gly m 1. Its application to assess environmental exposure to soybean dust. *Allergy* 2000;55(1):59-64.
- [33] Gordon S. Laboratory animal allergy: A british perspective on a global problem. *ILAR J* 2001;42(1):37-46.
- [34] Gomez-Olles S, Cruz MJ, Renstrom A, Doekes G, Morell F, Rodrigo MJ. An amplified sandwich EIA for the measurement of soy aeroallergens. *Clin Exp Allergy* 2006;36(9):1176-83.
- [35] Tarlo SM, Purdham J. Air sampling in occupational asthma. *J Allergy Clin Immunol* 2002; 109(4): 603-5.
- [36] Gomez-Olles S, Cruz MJ, Bogdanovic J, Wouters IM, Doekes G, Sander I, et al. Assessment of soy aeroallergen levels in different work environments. *Clin Exp Allergy* 2007;37(12):1863-72.
- [37] Renstrom A, Gordon S, Hollander A, Spithoven J, Larsson PH, Venables KM, et al. Comparison of methods to assess airborne rat and mouse allergen levels. II. Factors influencing antigen detection. *Allergy* 1999; 54(2):150-7.



Soybean - Applications and Technology

Edited by Prof. Tzi-Bun Ng

ISBN 978-953-307-207-4

Hard cover, 402 pages

Publisher InTech

Published online 03, February, 2011

Published in print edition February, 2011

Soybean is an agricultural crop of tremendous economic importance. Soybean and food items derived from it form dietary components of numerous people, especially those living in the Orient. The health benefits of soybean have attracted the attention of nutritionists as well as common people.

How to reference

In order to correctly reference this scholarly work, feel free to copy and paste the following:

María-Jesús Cruz and Susana Gómez-Ollé (2011). Immunoquantitative Measurement of Soybean Aeroallergen Emissions, Soybean - Applications and Technology, Prof. Tzi-Bun Ng (Ed.), ISBN: 978-953-307-207-4, InTech, Available from: <http://www.intechopen.com/books/soybean-applications-and-technology/immunoquantitative-measurement-of-soybean-aeroallergen-emissions>

INTECH

open science | open minds

InTech Europe

University Campus STeP Ri
Slavka Krautzeka 83/A
51000 Rijeka, Croatia
Phone: +385 (51) 770 447
Fax: +385 (51) 686 166
www.intechopen.com

InTech China

Unit 405, Office Block, Hotel Equatorial Shanghai
No.65, Yan An Road (West), Shanghai, 200040, China
中国上海市延安西路65号上海国际贵都大饭店办公楼405单元
Phone: +86-21-62489820
Fax: +86-21-62489821

© 2011 The Author(s). Licensee IntechOpen. This chapter is distributed under the terms of the [Creative Commons Attribution-NonCommercial-ShareAlike-3.0 License](#), which permits use, distribution and reproduction for non-commercial purposes, provided the original is properly cited and derivative works building on this content are distributed under the same license.

Recovery of Phytosterols from Waste Residue of Soybean Oil Deodorizer Distillate

Feng Yan², Haojun Yang¹, Daogeng Wu¹, Ming Huo¹ and Jianxin Li^{*1,3}

¹*State Key Laboratory of Hollow Fiber Membrane Materials and Processes,
Tianjin Polytechnic University, Tianjin 300160*

²*School of Environmental and Chemical Engineering,
Tianjin Polytechnic University, Tianjin 300160*

³*Shanghai Advanced Research Institute,
Chinese Academy of Science, Shanghai 201203
P. R. China*

1. Introduction

Phytosterols are triterpenes similar to cholesterol, both in structure, given the four-ring steroid nucleus, the 3 β -hydroxyl group and often a 5, 6-double bond and in function, given their role in the stabilization of the phospholipid bilayers in cell membranes. Sterols in plants exist in the form of free alcohols, fatty-acid esters, steryl glycosides and acylated steryl glycosides (Fernandes and Cabral, 2007). Phytosterols play major roles in several areas, namely in pharmaceuticals (production of therapeutic steroids), nutrition (anti-cholesterol additives in functional foods, anti-cancer properties), and cosmetics (creams, lipstick) (Fernandes and Cabral, 2007). Phytosterols are known to have cholesterol-lowering effect. The mechanism played by phytosterols is based on the ability of plant sterol esters to reduce the intestinal absorption of diet and biliary cholesterol. Moreover, plant sterols possess anti-inflammatory and anti-atherogenicity activity and may possess anti-cancer and anti-oxidative activities. Overall, phytosterol applications are promising.

Soybean oil deodorizer distillate (SODD) is obtained as a byproduct of the deodorization step during the refining of soybean oil. In the refining of soybean oil, most bioactive compounds such as free phytosterols, fatty acid steryl esters (FASEs), tocopherols and squalenes are concentrated (Woerfel, 1995; Verleyen et al., 2001). Furthermore, SODD also contains free fatty acids (FFAs), polycyclic hydrocarbons and the bioactive compounds (Bockisch, 1998). Thus, SODD is a natural source of phytosterols (or fatty acid sterol esters, FASEs), free fatty acids (or fatty acid methyl esters, FAMES, namely biodiesel), tocopherols and squalenes. Several strategies have been developed to recover and purify these compounds from the deodorizer distillate of vegetable oils. Many methods have been proposed especially to recover phytosterols or FASEs from the deodorizer distillate.

Torres et al. (2007) reported that a two step enzymatic procedure could be used to obtain FASEs and FAMES from soybean oil deodorizer distillate. Two enzymatic steps were used to separate sterols esterification and ethyl esterification. Guclu-Ustundag and Temelli (2007) developed a semi-continuous column fractionation of canola oil deodorizer distillate using

supercritical CO₂ (SCCO₂) to determine the feasibility of value-added processing of this feed material for the recovery of bioactive components such as sterols and tocopherols and the effect of operating conditions on extract yield and separation efficiency. Gunawan et al. (2008) described a suitable method (without degradation of the FASEs) i.e. modified Soxhlet extraction, modified silica gel column chromatography and binary solvent extraction to isolate and purify natural FASEs from SODD. FASEs with a purity of 86.74% and a total recovery of 85.32% could be obtained in the final products.

Sun et al. (1998) developed a process including esterification, water-bathing, alcoholysis, cooling precipitation and distillation to extract tocopherols and sterols from by-products of refined vegetable oil. Free sterols, fatty acid methyl ester and tocopherols can be separated efficiently from DD. Although the process has no effect on extracting fatty acid methyl ester from SODD, it is still commonly used in industry. A modified process was developed by Xu et al. (2005) to recover and purify valuable compounds from SODD. In its industrial production, tocopherols and FAMES was obtained from SODD after a process of methyl esterification by sulfuric acid catalyst, transesterification by alkaline catalyst, crystallization of sterols and molecular distillation. The waste residue of SODD (WRSODD) was obtained after the molecular distillation. WRSODD mainly contains steryl esters, acylglycerols, and hydrocarbons.

In order to be environmentally friendly for the utilization of waste resources and energy saving, the development of a suitable method to recover phytosterols from WRSODD is of great importance. Zhang et al. (1991) described a process route for the preparation of β -sitosterol from the unsaponifiable matter in tall oil. However, the average yield of β -sitosterol is low, only 1 wt%. Li and Wang (2004) reported a method to extract phytosterols from plant oil pitch or tall oil pitch, but the yield is low, only 6 wt%-10 wt%. Until now, there is no literature related to the extraction of phytosterols from WRSODD.

The purpose of the present study is to develop a catalytic and crystallization process to recover phytosterols from WRSODD. A catalyst was employed to decompose WRSODD so as to transform steryl esters into phytosterols. Several solvents were used for the crystallization of the phytosterols. The effect of different solvents on the purity and yield of recovered phytosterols was investigated. Silica gel column chromatography and FT-IR spectrum analysis were adopted to analyze the composition of WRSODD. The structure and purity of the recovered phytosterols were determined by FT-IR spectrum and gas chromatography (GC).

2. Experimental

2.1 Materials

WRSODD and standard samples of phytosterols were provided by CGOG TECH. Bioengineering Co. Ltd., Tianjin, China. Silica gel (G60) was purchased from Qingdao Haiyang Chemical Co., Ltd., Shandong, China. Cholesterols (>97 %) were from Tianjin Guanfu Fine Chemical Research Institute, China. Other chemicals, such as acetic anhydride, pyridine, methanol, ethanol, n-propanol, n-hexane, cyclohexane, petroleum ether, acetone, butanone, cyclohexanone, benzene, toluene are all analytic reagents and were used as received.

2.2 Component separation of WRSODD

In order to illustrate the compositions of WRSODD, column chromatography was used to separate WRSODD into different polarity fractions. The process was as follows: the column was packed with silica gel 60 and the sample (WRSODD) was placed on the top layer of the

column. The sample was eluted by petroleum ether, ethyl acetate and ethanol sequentially. Petroleum ether as a low polarity solvent was first used to elute the sample until the eluent became colorless. Meanwhile, TLC was used to estimate if all the low polarity compositions had been eluted. Ethyl acetate was then used to elute the sample until the eluent became colorless. In like manner, TLC was employed to determine if all the medium polarity compositions had been eluted. Lastly, ethanol was used to elute the sample until the eluent became colorless. Elution I, Elution II and Elution III were obtained after evaporating petroleum ether, ethyl acetate and ethanol, respectively.

2.3 Analysis methods

FT-IR spectra were recorded on Bruker Tensor 307 Spectrometer, BRUKER Co.

Gas chromatograph (GC) (Agilent 6890N, USA) with a HP-5 capillary column was employed to analyze the purity of sterols. All the samples of sterols were derivatized with acetic anhydride and pyridine before testing. Cholesterols were used as an internal standard. The purity of sterols can be calculated by Eq. (1).

$$Y = F \frac{A_{\text{sample}} \times m_{\text{internal}}}{A_{\text{internal}} \times m_{\text{sample}}} \times 100\% \quad (1)$$

where Y is the purity of sterols (%), F the correction factor, A_{sample} the total peak area of sterols (brassicasterols, campesterols, stigmasterols and β -sitosterols) in a sample, A_{internal} the total peak area of internal standard, m_{internal} the mass of the internal standard (mg), m_{sample} the mass of a sample (mg). Note: the correction factor F can be obtained from the sample with a purity of 95.30% from CGOG Tech. (Tianjin) Bioengineering Co., Ltd.

Gas chromatography-mass spectrometry (GC-MS) (HP5890-5971, USA) was further employed to confirm that the relative retention time of the peaks corresponds to certain sterols in the gas chromatogram.

Thin layer chromatography (TLC) was adopted to carry out chromogenic reactions of FASEs. Elution I and Elution II were developed by the mixture of hexane and ethyl acetate on TLC plates. Spots for FASEs and steroidal hydrocarbons were detected by spraying with a fresh solution of ferric chloride (50mg) in a mixture of water (90ml), acetic acid (5ml) and sulfuric acid (5ml). After the plates were heated at 100°C for 3-5 min, FASEs and steroidal hydrocarbons were detected by a red-violet color (Gunawan, et al., 2008).

2.4 Reaction procedure

The reaction process comprised the following steps: Firstly, the WRSODD was dissolved in ethanol in a three neck flask, and an alkali solution (40 wt%) was added into the flask as a catalyst to react at suitable temperature for several hours while stirring. Secondly, excess acid was added into the mixture to stop the reaction. The mixture was then repeatedly washed with water until pH 7 was achieved. The fatty acid steryl esters in WRSODD were then transformed to free sterols and free fatty acids.

2.5 Total content of phytosterols determination in WRSODD

Column chromatography was used to separate high polarity and fuscous components from WRSODD. The mixture of petroleum ether and ethyl acetate as a low polarity solvent was employed to elute the sample until it became colorless. The concentration of steryl esters

was obtained after removing the solvent. The concentrated feed was then saponified so as to transform the fatty acid steryl esters in WRSODD into free sterols and FFAs, and the glycerides into FFAs and glycerol as illustrated in Section 2.4. After that, free phytosterols were extracted by petroleum ether and obtained after the evaporation of the solvent. Finally, GC was employed to determine the content of sterols in the concentration of free phytosterols as illustrated in Section 2.3.

2.6 Phytosterols recovery from the feed solution after catalytic decomposing reaction

2.6.1 Selection of solvents for crystallization

The feed solution obtained from the catalytic decomposing reaction contained a large amount of free phytosterols, free fatty acids, organic phosphates, polyalcohols, carbohydrates and other miscellaneous components. Phytosterols could be recovered by crystallization from the complex feed solution. The feed was dissolved in different solvents, such as alcohols, alkanes, ketones, benzenes and mixed solvents, and the phytosterols were then crystallized by cooling at a cooling rate of 2 °C per hour. Phytosterols crystals were finally obtained by vacuum filtration.

2.6.2 Optimization of crystallization conditions

Orthogonal experiments were carried out to optimize the crystallization conditions. Three key parameters, namely the proportion of feed solution to solvent, ripening time and ripening temperature, were optimized by orthogonal experiments.

Table 1 lists the schedule of the orthogonal test in which the key parameters including the proportion of feed solution to solvent (A), ripening time (B) and ripening temperature (C) were selected as three factors. Every factor had three levels to be optimized.

| | Factor A (The proportion of feed to solvent) | Factor B (Ripening time) | Factor C (Ripening temperature) |
|---------|---|-----------------------------|------------------------------------|
| Level 1 | 1:1 | 4 | -8 |
| Level 2 | 1:2.5 | 14 | 6 |
| Level 3 | 1:4 | 24 | 20 |

Table 1. Factors and levels selected for orthogonal experiments

3. Results and discussion

3.1 Composition analysis of WRSODD

3.1.1 Separation of WRSODD by column chromatography

According to the different polarities of solvents used, three different elutions (Elution I, Elution II and Elution III) were separated sequentially from the WRSODD by column chromatography. The WRSODD was separated into four kinds of compositions. Their contents were 88.27 wt% in Elution I, 9.74 wt% in Elution II, 0.8 wt% in Elution III and 1.19 wt% left. The portion of Elution I was much larger than the others. It suggests that there were many low polarity components in the WRSODD, which might be fatty acid steryl esters and glycerides. The further structural investigation was carried out by FT-IR and TLC as follows.

3.1.2 Analysis of elutions by FT-IR

According to the IR spectrum of Elution I, the potential functional groups can be seen in Table 2. The ring vibration at 1011 cm^{-1} corresponds to the character of a steroid. The C=O and C-O-C stretching bands at 1738 cm^{-1} and 1176 cm^{-1} , and without the -OH group characteristic absorption band above 3000 cm^{-1} , indicate the presence of fatty acid steryl esters and glycerides. The band at 724 cm^{-1} indicates that there are four or more CH_2 groups in the chain. The band at 1464 cm^{-1} is the scissoring frequency of CH_2 or CH_3 groups and the band 1377 cm^{-1} shows the symmetrical bending model of a CH_3 group. The bands at 2926 cm^{-1} and 2852 cm^{-1} are inferred to be the stretching vibration of CH_3 and CH_2 groups. All the above observations imply the presence of long carbon chain groups for FASEs and glycerides.

| Elution I | Adscription | Potential functional groups |
|-----------|-------------------|--------------------------------|
| 2926 (s) | vCH | $-\text{CH}_3$ $-\text{CH}_2-$ |
| 2852 (s) | vCH | $-\text{CH}_3$ $-\text{CH}_2-$ |
| 1738 (s) | vC=O | R-CO-OR' |
| 1464 (m) | δCH | $-\text{CH}_2-$ $-\text{CH}_3$ |
| 1377 (m) | δCH | $-\text{CH}_3$ |
| 1176 (m) | vC-O-C | ROOR' |
| 1011(w) | ring vibration | polycyclic compounds |
| 724(w) | vCH | $-(\text{CH}_2)_n-(n>4)$ |

Note: w, weak intensity; m, middle intensity; s, strong intensity; v, stretching vibration; δ , deformation vibration

Table 2. FT-IR bands of Elution I

FT-IR spectra of Elution II and Elution III were obtained. Compared with the spectrum of Elution I, the spectrum of Elution II shows hydroxy stretching vibration at 3437 cm^{-1} and the weak ring vibration at 1011 cm^{-1} . Accordingly, the medium polar substances in Elution II may be polyalcohols or carbohydrates with long carbon chain groups. It can be seen from the spectrum of Elution III that the wide band from 3500 cm^{-1} to 2500 cm^{-1} may be the stretching vibration of -OH from carboxylic acid. The absorption bands at 1568 cm^{-1} and 1202 cm^{-1} respond to amino group and nitril group. This indicates that Elution III contains nitrogenous compounds. It is the reason that the color of the residue is dark brown. The absorption band at 1739 cm^{-1} corresponds to carbonyls stretching vibration, which may come from carboxylic acids and esters. The band at 3361 cm^{-1} is related to hydroxy groups. Accordingly, the Elution III has the strongest polarity among the three elutions.

3.1.3 Analysis of elution by TLC

Chromogenic reactions of FASE were carried out by using TLC. The results showed that the frontier of Elution I on the plate exhibited a red-violet color, while that of Elution II did not. This phenomenon further confirmed the existence of fatty acid steryl esters in Elution I.

3.1.4 Total content of phytosterols in WRSODD

As mentioned in Section 2.5, free phytosterols were obtained of WRSODD by purification, saponification and extraction processes. The content of phytosterols was determined by GC. The analysis results showed that the average of total sterol content in the WRSODD from

CGOG TECH Bioengineering Co. Ltd, China and Heilongjiang Jiusan Oil & Fat Co. Ltd, China was 27.09 % and 27.36 %, respectively.

3.2 Phytosterols recovery from the feed solution

Phytosterols can be recovered by crystallization of the complex feed solution. The precipitation of any given substance from a solution by crystallization is a direct consequence of its supersaturation. It can be achieved by solvent evaporation or by changing temperature if the solubility of the desired substance is temperature-dependent. The main process used to separate phytosterols from feed solution is to cool or chill the solution after a suitable solvent has been added. Thus the selection of a suitable solvent is the most important.

3.2.1 Selection of solvents for crystallization

In the present work, various alcohols, alkanes, ketones, aromatics, and their mixed solvents were used to explore the effect of different solvents on the crystallization of phytosterols from feed solution. The results are shown in Table 3.

The solubilities of sterols in alcohols increased with the increase in hydrocarbon chains for Test No. 1-3 as shown in Table 3. Methanol is invalid, since it could not dissolve the feed. The phytosterols product extracted by ethanol had the purity of 89.56 wt% and the yield of 21.06 wt%. The yield of phytosterols extracted by n-propanol was only 6.89 wt%, which was due to the high solubility of phytosterols in n-propanol. It can be also seen from Table 3 that the product with a high purity of above 90 wt% and a high yield of over 17 wt% was obtained by using alkanes. However, they are too expensive for commercial production.

| No. | Solvent | Dissolving temperature (°C) | Ripening temperature (°C) | Ripening time(h) | Crystal color | Crystal, morphology | Purity (wt%) | Yield (wt%) |
|-----|---------------------|-----------------------------|---------------------------|------------------|----------------------------|---------------------|--------------|-------------|
| 1 | methanol | undissolved | / | / | / | / | / | / |
| 2 | ethanol | 65 | 8 | 24 | yellowish | needlelike | 89.56 | 21.06 |
| 3 | n-propanol | 65 | 8 | 24 | Whitish (yellowish partly) | planar | 89.59 | 6.89 |
| 4 | n-hexane | 65 | 8 | 24 | whitish | floc | 92.90 | 22.04 |
| 5 | cyclohexane | 65 | 8 | 24 | bright white | planar | 92.88 | 17.03 |
| 6 | Petroleum ether | 65 | 8 | 24 | whitish | floc | 91.98 | 22.37 |
| 7 | acetone | 65 | 8 | 24 | gray yellow | floc | 89.31 | 19.16 |
| 8 | butanone | 65 | 8 | 24 | white | planar | 93.03 | 12.49 |
| 9 | cyclohexanone | 60 | 5 | 24 | whitish | floc | 93.34 | 7.89 |
| 10 | benzene | 65 | 8 | 24 | yellowish | needlelike | 89.77 | 9.63 |
| 11 | toluene | 65 | 8 | 24 | white | floc | 94.20 | 6.69 |
| 12 | Acetone/ethanol=4/1 | 60 | 5 | 24 | yellowish | needlelike | 91.82 | 22.95 |

Table 3. Experiment results of crystallization in different solvents

Furthermore, the phytosterols with a high purity were obtained by using butanone, cyclohexanone, benzene and toluene. However their yields were very low. Taking their toxicity into account, they are all not desirable solvents for phytosterol crystallization.

Furthermore, Table 3 showed that a product extracted by acetone had a purity of 89.31 wt% and a passable yield of 19.16 wt%. An interesting phenomenon can be seen was that the mixture of ethanol and acetone as a mixed solvent showed good crystallization efficiency. The purity of the product extracted by the mixed solvent (acetone/ethanol=4/1, v/v) was 91.82 wt%, and its yield was 22.95 wt%.

Taking all factors into consideration, the mixture of acetone and ethanol (volume ratio=4/1) as a mixed solvent with low cost and low toxicity could generate good crystallization of phytosterols with good crystal morphology, acceptable color, high purity and high yield.

3.2.2 Selection of crystallization conditions

Orthogonal experiments were implemented to optimize the crystallization conditions of phytosterols extracted by the mixed solvent (acetone/ethanol=4/1, v/v). The results of orthogonal experiments are listed in Table 4. The orthogonal table L₉(3⁴) was used to array the factors. The purity and yield of the recovered phytosterols were taken as the index points to evaluate the crystallization efficiency under different factors and levels.

| Series No. | Level of A | Level of B | Level of C | Crystal color | Purity (wt%) | Yield (wt%) |
|------------|------------|------------|------------|---------------|--------------|-------------|
| 1 | 1:1 | 4 | -8 | whitish | 91.45 | 19.82 |
| 2 | 1:1 | 14 | 6 | whitish | 89.85 | 19.10 |
| 3 | 1:1 | 24 | 20 | white | 91.17 | 18.73 |
| 4 | 1:2.5 | 4 | 6 | yellowish | 87.85 | 18.74 |
| 5 | 1:2.5 | 14 | 20 | white | 90.15 | 18.67 |
| 6 | 1:2.5 | 24 | -8 | brown yellow | 81.87 | 23.90 |
| 7 | 1:4 | 4 | 20 | whitish | 92.06 | 15.65 |
| 8 | 1:4 | 14 | -8 | yellow | 84.85 | 20.82 |
| 9 | 1:4 | 24 | 6 | yellowish | 87.09 | 19.34 |

Table 4. Detailed schemes of orthogonal test and property results of crystallization

The range (R) analysis results of orthogonal experiments are shown in Table 5. The influence on the purity of recovered phytosterols was in the order: C>A>B, and the influence on the yield of recovered phytosterols was in the order: C>B>A. These suggested that the factor of ripening temperature (C) showed the most notable influence on whichever index points. Then the factor of ripening time (B) had the relatively remarkable influence compared with the proportion of feed solution to solvent (A) on the yield of phytosterols. Contrarily, the proportion of feed solution to solvent (A) had more influence on the purity of recovered phytosterols.

It can also be seen from Table 5 that the optimal crystallization conditions to obtain highest purity of recovered phytosterols were A1B1C3 when the proportion of feed to solvent was 1/1 (mass/mass), the ripening time was 4 hours, and the ripening temperature was 20°C (room temperature) (Table 1). By comparison, the optimal crystallization conditions in terms of yield were A2B3C1, namely, the proportion of feed solution to solvent 1/2.5 (mass/mass), the ripening time 24 hours, and the ripening temperature -8°C (chilling temperature).

| k | Purity (wt%) | | | Yield (wt%) | | |
|---|--------------------------------------|------------------------------|---|--------------------------------------|------------------------------|--------------------------------------|
| | A Feed /solvent (mass/mass) | B Ripening time (h) | C Ripening temperature (°C) | A Feed /solvent (mass/mass) | B Ripening time (h) | C Ripening temperature (°C) |
| k1 | 90.82 | 90.45 | 86.06 | 19.22 | 18.07 | 21.51 |
| k2 | 86.62 | 88.28 | 88.26 | 20.43 | 19.53 | 19.06 |
| k3 | 88.00 | 86.71 | 91.13 | 18.60 | 20.66 | 17.68 |
| R | 4.20 | 3.74 | 5.07 | 1.83 | 2.59 | 3.83 |
| The order of the influence factors C>A>B | | | The order of the influence factors C>B>A | | | |
| The optimal scheme A1B1C3 | | | The optimal scheme A2B3C1 | | | |

Note: k_i represents the average of experimental values corresponding to level i ($i=1, 2, 3$). R represents the range which indicates how far it is from the lowest k_i to the highest k_i for a certain factor.

Table 5. Range analysis of orthogonal experimental results on purity and yield of recovered phytosterols

The effect of factors on the yield and purity of recovered phytosterols obtained in Table 5 was illustrated in Fig. 1. As shown in Fig. 1, the maximum yield of recovered phytosterols was obtained when the proportion of feed to solvent (A) was 1:2.5 (mass/mass) (Table 1). The yield increased with an increase in the ripening time (B) and decreased with an increase in the ripening temperature (C). On the contrary, the minimum purity of recovered phytosterols appeared when the proportion of feed to solvent (A) was 1:2.5 (mass/mass) (Table 1) as shown in Fig.1. The purity decreased with an increase in the ripening time (B) and increased with an increase in the ripening temperature (C).

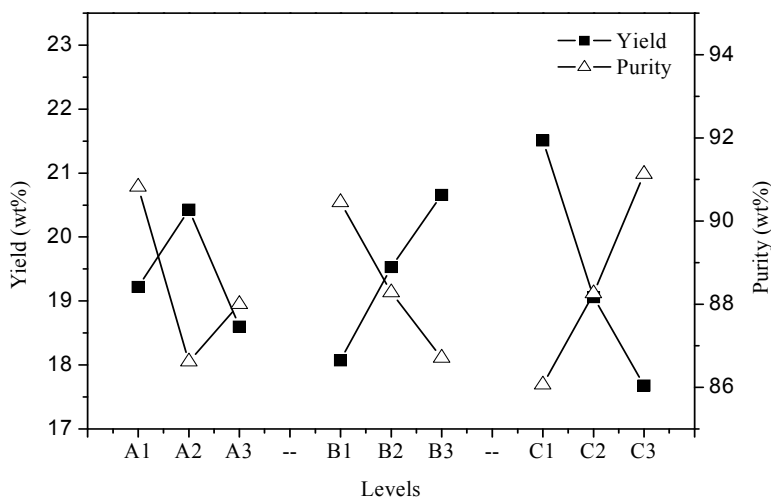

Fig. 1. Effect of factors on the yield and purity of recovered phytosterols under different levels.

In sum, the optimum crystallization conditions obtained were the proportion of feed solution to solvent 1:2.5 (mass/mass), the ripening time 24 h and the ripening temperature 6°C (cooling temperature). Following above optimized crystallization conditions, the phytosterols with a purity of 91.82 wt% and a yield of 22.95 wt% were obtained.

3.3 Purity and structure of recovered phytosterols

The structure and purity of recovered phytosterols were analyzed by FT-IR, GC and GC-MS, respectively.

3.3.1 Structure analysis of recovered phytosterols by FT-IR

It can be seen in the FT-IR spectrum of recovered phytosterols (the 3rd crystallization) that the absorption wide band at 3428 cm⁻¹ is inferred to be the stretching vibration of -OH from sterols. The absorption bands at 2936 cm⁻¹ and 2867 cm⁻¹ are inferred to be the stretching vibration of CH₃ and CH₂ groups, which imply the presence of long carbon side chain of sterols. No absorption bands between 1750 cm⁻¹ and 1735 cm⁻¹ can be observed. It indicates that no ester carbonyl group is present, which implies that esters have been hydrolyzed. The band at 961 cm⁻¹ is the double band characteristic peak of phytosterols (Wang, et al., 2002). The FT-IR spectrum of recovered phytosterols was in accordance with the standard spectrum of cholesterol, without functional groups of impurities. Further, the purity of recovered phytosterols was determined by GC and GC-MS.

3.3.2 Purity analysis of recovered phytosterols by GC and GC-MS

GC was employed to determine the purity of recovered samples of phytosterols. The results from GC of recovered samples of phytosterols obtained by the 3rd crystallization show that cholesterol (internal standard), brassicasterols, campesterols, stigmasterols and β -sitosterols were eluted with the relative retention time of 12.364, 12.888, 13.783, 14.249 and 15.223 min, respectively. According to the peak areas of sterols and internal standard and Equation (1), the purity of phytosterols sample recovered by the 3rd crystallization was calculated to be 97.17%. Following this calculation method, the purity of recovered phytosterols reached 91.82 wt% after the 1st crystallization and 92.73 wt% after the 2nd crystallization.

GC-MS was further utilized to investigate that the relative retention time of the peaks corresponds to certain sterols in the gas chromatogram. The mass spectrometry (MS) of each sterol peak is shown in Fig.2. It can be seen from Fig.2 that the maximum detectable mass of the GC-MS system was less than the molecular mass of correspondent sterol acetates by 60 mass units. Therefore, the characteristic peaks were corresponding to the loss of one molecule of acetate from molecular ions. For instance, the molecular mass of stigmasteryl acetates is about 454, and the maximum detectable mass of its MS is 394.2 (Fig. 2c). Their different value is about 60. It indicated that one molecule of acetate was lost. Furthermore, the MS of all the correspondent sterol acetates had the primary fragment peaks of m/z 255. It inferred that sterol acetates possessed steroidal nucleus (Zeng et al., 1994).

4. Conclusion

There is a large amount of combined phytosterols in the waste residue of soybean oil deodorizer distillate. This study describes a catalytic decomposition and crystallization process to recover phytosterols from WRSODD. Results showed that the total amount of

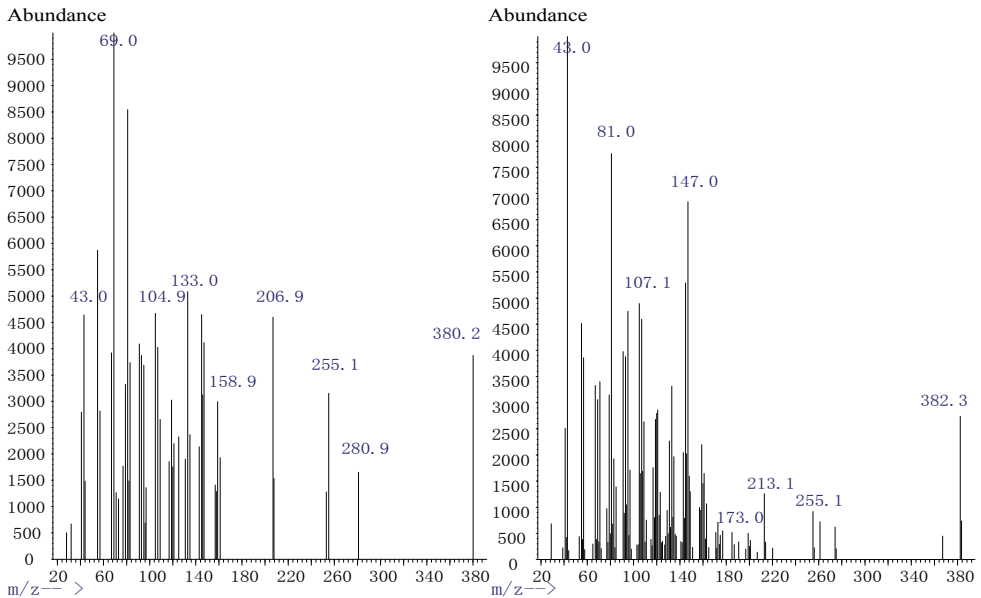

(a) MS of brassicasteryl acetates

(b) MS of campesteryl acetates

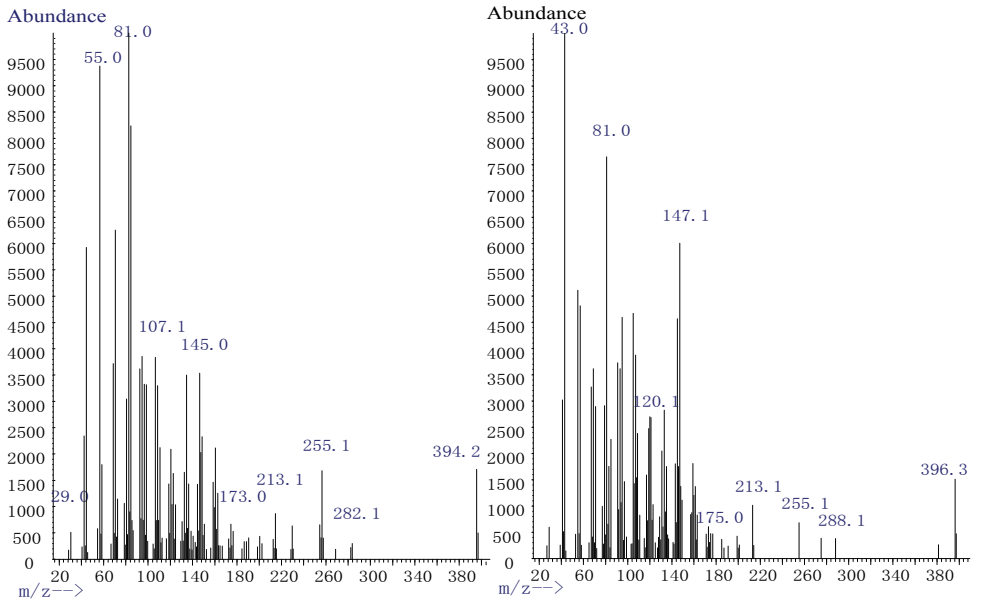

(c) MS of stigmasteryl acetates

(d) MS of β -sitosteryl acetates

Fig. 2. The MS of steryl acetates

phytosterols, in the form of fatty acid steryl esters, was up to 27 wt% of WRSODD. The fatty acid steryl esters were decomposed by NaOH, and various solvents were then used for the crystallization of phytosterols. It was shown that the mixture of acetone and ethanol (volume ratio=4/1) could generate good crystallization of phytosterols with good crystal morphology, high purity and yield. Furthermore, the optimum crystallization conditions were obtained through orthogonal experiments. The phytosterols with purity of 91.82 wt% and yield of 22.95 wt% were obtained after the 1st crystallization under the optimized crystallization conditions, and the recovery rate was up to 84.7 % of total phytosterols. Moreover, the purity of recovered phytosterols obtained by GC-MS reached 92.73 wt% after the 2nd crystallization and 97.17 wt% after the 3rd crystallization.

5. Acknowledgements

The authors gratefully acknowledge the financial support by National High Technology Research and Development Program of China ("863" Program, Grant No.2009AA03Z223) and Tianjin Natural Science Foundation (Grant No.08JCYBJC26400 and 08JCZDJC24000).

6. References

- Bockisch M. (1998). *Fats and Oils Handbook*, American Oil Chemists' Society, Champaign, IL, pp. 613-718
- Fernandes P.; Cabral J. M. S. (2007). Phytosterols: Applications and recovery methods. *Bioresour. Technol.* 98, 2335-2350
- Guclu-Ustundag O.; Temelli F. (2007). Column fractionation of canola oil deodorizer distillate using supercritical carbon dioxide. *J. Am. Oil. Chem. Soc.* 84, 953-961
- Gunawan S.; Fabian C. & Ju Y. H. (2008). Isolation and purification of fatty acid steryl esters from soybean oil deodorizer distillate. *Ind. Eng. Chem. Res.* 47, 7013-7018
- Li C.; Wang S. (2004). Study of the process of extracting phytosterols from plant oil pitch or tall oil pitch. *Sci. Tech. Food Ind.* 6, 111-112
- Sun D.; Qu D.; Liu F.; Lu Z. (1998). A new process to extract tocopherols and sterols from by-product of refined vegetable oil. CN Patent ZL 93100259
- Torres C. F.; Torrelo G.; Señorans F. J.; Reglero G. (2007). A two steps enzymatic procedure to obtain sterol esters, tocopherols and fatty acid ethyl esters from soybean oil deodorizer distillate. *Process Biochem.* 42, 1335-1341
- Verleyen T.; Verhe R.; Garcia L.; Dewettinck K.; Huyghebaert A.; De Greyt W. (2001). Gas chromatographic characterization of vegetable oil deodorization distillate. *J. Chromatogr. A* 921, 277-285
- Wang Y.; Xu W.; Huang Y. (2002). Study on the recrystallization purification and separation of stigmaterols from phytosterols. *J. Yangzhou Univ. (Natural Science Edition)*. 5, 53-56
- Woerfel J. B. (1995). Soybean oil processing byproducts and their utilization, in: D. R. Erickson (Ed.), *Practical Handbook of Soybean Processing and Utilization*, edited by D. R. Erickson, American Oil Chemists' Society, Champaign, IL, pp. 297-313
- Xu Y.; Shi X.; Du X.; Xing M.; Xu T.; Meng J.; Feng Z. (2005). A method to extract natural vitamin E from by-product fo refined vegetable, CN Patent ZL 200510114851.X

- Zeng Z.; Zeng L. M. & Xiang T. S. (1994). The regular patterns of mass spectrometry of sterols and related derivatives. *Journal of Chinese mass spectrometry society*. 15, 11-15
- Zhang X.; Ma L.; Huo X.; Zhang J. (1991). Process study on isolation of β -sitosterol from tall oil. *Chn. J. Pharmaceuticals*. 22, 199-200

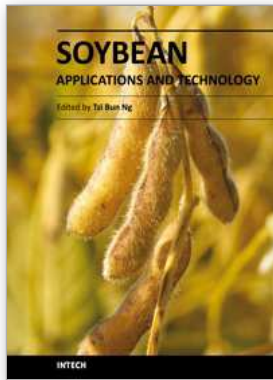

Soybean - Applications and Technology

Edited by Prof. Tzi-Bun Ng

ISBN 978-953-307-207-4

Hard cover, 402 pages

Publisher InTech

Published online 26, April, 2011

Published in print edition April, 2011

Soybean is an agricultural crop of tremendous economic importance. Soybean and food items derived from it form dietary components of numerous people, especially those living in the Orient. The health benefits of soybean have attracted the attention of nutritionists as well as common people.

How to reference

In order to correctly reference this scholarly work, feel free to copy and paste the following:

Feng Yan, Haojun Yang, Daogeng Wu, Ming Huo and Jianxin Li (2011). Recovery of Phytosterols from Waste Residue of Soybean Oil Deodorizer Distillate, Soybean - Applications and Technology, Prof. Tzi-Bun Ng (Ed.), ISBN: 978-953-307-207-4, InTech, Available from: <http://www.intechopen.com/books/soybean-applications-and-technology/recovery-of-phytosterols-from-waste-residue-of-soybean-oil-deodorizer-distillate>

INTECH

open science | open minds

InTech Europe

University Campus STeP Ri
Slavka Krautzeka 83/A
51000 Rijeka, Croatia
Phone: +385 (51) 770 447
Fax: +385 (51) 686 166
www.intechopen.com

InTech China

Unit 405, Office Block, Hotel Equatorial Shanghai
No.65, Yan An Road (West), Shanghai, 200040, China
中国上海市延安西路65号上海国际贵都大饭店办公楼405单元
Phone: +86-21-62489820
Fax: +86-21-62489821

© 2011 The Author(s). Licensee IntechOpen. This chapter is distributed under the terms of the [Creative Commons Attribution-NonCommercial-ShareAlike-3.0 License](#), which permits use, distribution and reproduction for non-commercial purposes, provided the original is properly cited and derivative works building on this content are distributed under the same license.

Soybean-based Surfactants and Their Applications

Qingyi Xu¹, Mitsutoshi Nakajima², Zengshe Liu³ and Takeo Shiina¹

¹*National Food Research Institute,*

²*University of Tsukuba,*

³*NCAUR/ARS/USDA,*

^{1,2}*Japan*

³*U.S.A*

1. Introduction

The soybean is a legume that contains no cholesterol and is low in saturated fat. Soybeans have been consumed as a major source of protein by people in Asia for centuries, while their consumption in the West only spans several decades. The soybean is the only vegetable food that contains all eight essential amino acids. It is also a good source of fibre, iron, calcium, zinc, and vitamins. In 2009, the world soybean production was 210.9 million metric tons, about 53% of the world oilseed production [American Soybean Association, 2010]. Soybeans are made up of about 40% protein and 20% oil and are therefore considered to be a major source of proteins and oils. They are also an important source of three natural surfactants: soy lecithin, soy protein, and soy saponin. However, the use of saponin has some limitations [Oleszek & Hamed, 2010]. In this chapter, we are focusing on soy lecithin and soy protein.

A surfactant is a surface-active substance. The molecular structure of a surfactant is characterised by the presence of hydrophilic heads and lipophilic tails. This structural property enables surfactant molecules to adsorb at surfaces or interfaces. Surfactants are generally classified according to the type and charge of the hydrophilic groups, namely, anionic, cationic, nonionic, and amphoteric surfactants. Surfactants are involved in many aspects of our lives, including detergents, cosmetics, foods, and drinks. Not only natural surfactants but also a wide range of synthetic surfactants are used in various applications. The world surfactant market was valued at about \$14.3 billion [Karsa & Houston, 2006] with a market volume of about 18 million tons [Cirelli et al., 2008] in 2003, and it reached \$23 billion in 2007 [Acmite Market Intelligence, 2008]. However, the market has recently been experiencing stricter regulations and has been hit by the current financial crisis. Surfactants can be produced both from oleochemical and petrochemical feedstocks. The use of natural renewable materials (e.g., seed oils and animal fats) to produce surfactants coupled with the development of new production methods may provide a solution to these challenges. Furthermore, it has been demonstrated by life cycle analysis that the use of renewable resources for surfactant production is more cost-effective and eco-friendly than petrochemical resources. The substitution of the use of seed oils for surfactant production would lead to a significant reduction in surfactant-associated CO₂ emissions [Patel, 2004]. Therefore, it is expected that the production of seed oil-based surfactants will continuously increase and that surfactants with novel and improved properties will be developed.

2. Soy lecithin

2.1 Composition of soy lecithin

The term "lecithin" is used to refer to a mixture of phospholipids, a natural constituent of animals and plants. Egg yolk is the primary animal source of lecithin, but it is too expensive for industrial applications. Lecithin is now predominantly manufactured from plant seeds, mainly from soybean oilseeds due to their abundant availability and low cost. Crude soybean oil contains 1-3% phospholipids. These phospholipids are extracted as a by-product at a pretreatment stage during oil refinement. The composition of lecithin varies according to the method of extraction and purification. Commercial soy lecithin contains about 65-75% phospholipids (PLs), 34% triglycerides, and smaller amounts of carbohydrates, pigments, sterols, and sterol glycosides [Dickinson, 1993]. The most common PLs in lecithin are phosphatidylcholine (PC), phosphatidylethanolamine (PE), and phosphatidylinositol (PI). The PC content ranges from 29-46%; PE, from 21-34%; and PI, from 13-21% [Garti, 2002]. Because of its structural and compositional properties, soy lecithin is widely used as an emulsifier, antioxidant, stabiliser, lubricant, wetting agent, and nutritional supplement [Li, 2006]. In this chapter, we are focusing on the structural and functional properties of soy lecithin related to its surface activity and use as a surfactant.

2.2 Structural and functional properties of soy lecithin

PLs are diglycerides with a phosphate group attached to the third carbon atom of the glycerol molecule. The structures of PLs are shown in Fig. 1. The head group can be choline, ethanolamine, or inositol to form PC, PE and PI. The fatty acid composition of PLs may differ in chain length and saturation due to their response to environmental conditions (Dornbos et al., 1989). PLs are amphipathic molecules with hydrophilic polar heads and hydrophobic nonpolar fatty acid tails. As amphipathic molecules, they tend to adsorb to surfaces or interfaces with the nonpolar fatty acid tails facing the surface or oil phase and the polar heads facing the water phase, resulting in a decrease in the surface or interfacial tension. The PL molecules at the surface of bubbles, oil droplets or water droplets act as barriers to stabilise them.

The molecules of PC and PE contain positively charged choline (for PC) and ethanolamine (for PE) groups and negatively charged phosphate and carbonyl groups. PC and PE are zwitterionic-type surfactants, and they are electrically neutral at neutral pH. PI has a net negative charge at neutral pH and is an anionic-type surfactant (Gierula et al., 1999; Wang & Wang, 2008). PC tends to facilitate the formation of oil-in-water (O/W) emulsions, while PE and, to a lesser extent, PI tend to facilitate the formation of water-in-oil (W/O) emulsions [McClements, 2005]. Because commercial lecithins are mixtures of phospholipids and other substances, their surface activities are a combined result of all surface active components. Lecithin is universally accepted for medicinal and food use because its constituent phospholipids can be metabolised *in vivo* [Dickinson, 1993]. Although lecithin is not particularly suitable for stabilising either O/W or W/O emulsions, it can be used to prepare both O/W and W/O emulsions when exposed to an appropriate pH, salt concentration, temperature, and oil/water ratio [McClements, 2005; Krawczyk, 1996]. PC and PE do not contribute significantly to the net charge on the emulsion droplets at physiological pH, whereas PI and other anionic components in lecithin contribute to the negative charge of the emulsion and thus to emulsion stability [Dickinson, 1993; Wang & Wang, 2008].

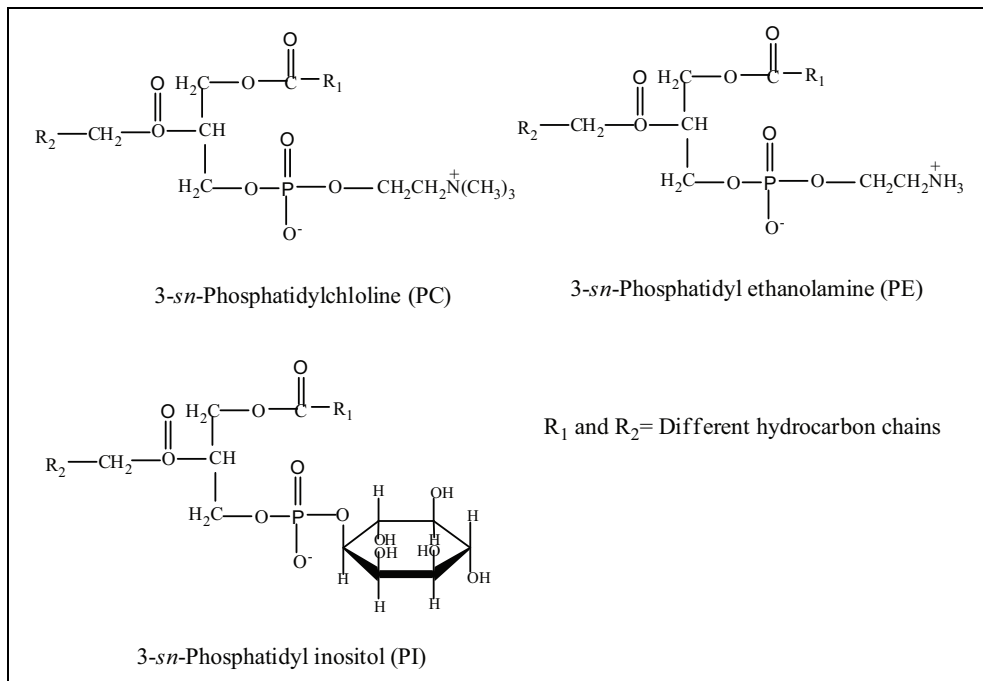

Fig. 1. Structures of phospholipids.

When dispersed in excess water above the chain melting temperature (CMT), PC and PI form a lamellar liquid crystal, whereas PE forms either a lamellar or hexagonal structure depending on the temperature, water content, and the composition of the hydrocarbon chains [Rydhaag & Wilton 1981]. In the case of mixed PLs, only the lamellar packing is formed. Rydhaag & Wilton (1981) reported that soy lecithin forms a lamellar liquid crystalline phase to stabilise O/W emulsions. A minimum thickness of the interfacial film of $\sim 80 \text{ \AA}$, corresponding to two double lipid layers, is required for the stabilisation the emulsions. They found that the amount of charged lipids has a strong effect on the ability of the lamellar liquid crystalline phase to swell with water. The charged components of lecithin contribute to the stability of the emulsions in terms of the fast adsorption to the oil/water interface, the formation of the swollen lamellar structures, and the electrostatic repulsion. Comas et al. [2006] observed that changing the pH from 6.2 to 2.0 resulted in an increase in the oil droplet diameter due to either the reduction in the surface activity of soy lecithin or the formation of a less resistive interfacial film. As a result, the droplets are more susceptible to coalescence in an acidic environment.

Lecithin forms reverse micelles in many organic solvents. The structure of reverse micelles depends on the concentration, temperature and water content. It has been demonstrated that giant cylindrical reverse micelles are formed when adding small amounts of water. A viscous gel referred to as organogel can then be formed as the water content increases. A further increase in the water content to a suitable content range results in the formation of stable W/O emulsions, which are stabilised by the presence of a lamellar phase and the viscous oil phase [Palazzo et al., 2003; Angelico et al., 2004; Stefan et al., 2003].

Conventional methods for preparing emulsions or bubble dispersions include mechanical homogenisation, sonication, and high-pressure homogenisation, which usually results in the formation of droplets or bubbles with wide size distributions. The demand for preparing droplets or bubbles with uniform sizes is increasing to improve the functionality and stability of products. Membrane emulsification [Nakashima et al., 1991] and microchannel emulsification [Kawakatsu et al., 1997] are two well-studied methods for preparing monodisperse emulsions. In these cases, the interaction between the charged groups of lecithin and the surface of membranes or microchannels may greatly influence the emulsification performance. The coalescence of the formed droplets and the continuous outflow of the oil phase through the microchannel were observed when using lecithin to produce an O/W emulsion with a silicon microchannel emulsification system. This was considered to be due to the attraction interaction between the positively charged groups of PC and PE and the negatively charged microchannel surface, causing the wetting of the surface of the microchannel by the oil phase. As a result, the surface of the microchannel lost its hydrophilicity and monodisperse droplets cannot be prepared. Increasing the experimental temperatures up to 70 °C did not improve the droplet production [Tong et al., 2002]. The most commonly used membrane for membrane emulsification is the Shirasu porous glass (SPG) membrane. The SPG membrane is suitable for the preparation of O/W emulsions because of the presence of negatively charged silanol groups on the membrane surface [Vladisavljević et al., 2005]. Surh et al. [2008] found that soy lecithin, despite its net negative charge, tends to foul SPG membranes by blocking the membrane pores due to the interaction between positive groups on the lecithin molecules and anionic silanol groups on the membrane surface.

2.3 Use of soy lecithin in combination with other additives

Although soy lecithins are important natural-sourced surfactants that have been used in various industries, they do not have a wide range of emulsifying properties [Dickinson, 1993]. Furthermore, emulsion products usually contain different components. The functional property of lecithin may be affected by the presence of other ingredients. PL-coated microbubbles have shown potential as ultrasound contrast agents and drug delivery systems. By using PL (*L*- α -phosphatidylcholine) in combination with an emulsifier (polyethylene glycol 40 stearate-40), stable microbubbles with diameters of less than 10 μm and narrow size distributions can be prepared by coaxial electrohydrodynamic atomisation (CEHDA) [Farook et al., 2009]. Extensive investigations have been performed on the use of soy lecithin in combination with proteins. Compared with other surfactants, the lecithin-protein interaction appears to be more complicated because of the complex liquid crystalline phases formed in water [Dickinson, 1997]. The interactions between protein and lecithin may change the structure of protein, leading to the formation of protein-lecithin complexes. As a result, the emulsifying properties and the electrostatic and steric repulsions may be changed. This may have synergistic effects on emulsion properties in some cases and antagonistic effects in others. The heat stability of caseinate-stabilised emulsions was found to be improved by adding lecithin before homogenisation [Crujisen, 1996]. McCrae [1999] demonstrated that lecithin does not exercise its effect on heat stability by interacting with free protein in solution but that it does with adsorbed proteins. However, the addition of lecithin destabilised whey protein hydrolysate-stabilised O/W emulsions, supposedly due to the displacement of protein molecules by the competitive adsorption of lecithin at the

interface [Agboobla et al., 1998]. The displacement of protein by lecithin was also observed in O/W emulsions stabilised by whey protein concentrate (WPC). However, no displacement of adsorbed protein by lecithin was found in the emulsions stabilised by β -lactoglobulin. The greater susceptibility of WPC to displacement from the surface of droplets by lecithin was explained as resulting from the denaturation of the protein [Dickinson & Yamamoto, 1996]. PLs are regarded to be less effective at competitively displacing milk proteins from the oil-water interface [Dickinson, 1997].

The presence of fat crystals can either stabilise or destabilise emulsion droplets, depending on which phase they are in. When present in the continuous phase, they may adsorb onto the droplet surfaces to stabilise the emulsion by providing a physical barrier. When present in the oil phase, they may destabilise O/W emulsions because the fat crystals stick out into the water phase and/or pierce the interfacial film [Boode et al., 1991; Rousseau, 2000]. Lecithin was found to affect the crystallisation of oil and thus have an impact on the stability of O/W emulsions [Miura et al., 2006]. The competitive adsorption of lecithin to displace proteins adsorbed at the oil/water interface may cause a change in the interactions between the proteins and fat crystals and thus affect the mechanical strength of the interfacial film [Ogden & Rosenthal, 1997], while the competitive adsorption of lecithin to displace proteins adsorbed at the surface of fat crystals may facilitate the coalescence of fat globules and thus destabilise the emulsions [Melsen & Walstra, 1989]. The adsorption of lecithin may also change the polarity of fat crystals [Johansson & Bergenst ahl, 1992; Rousseau, 2000].

Usually, low-molecular-weight surfactants are effective at generating emulsions with smaller droplets because of their fast adsorption to the newly created interfaces, but they may not be effective at providing long-term stability to the emulsions. The effect of the addition of sucrose and a non-gelling polymer (hydroxy ethyl cellulose) on the stability of lecithin-stabilised O/W emulsions was investigated by Castelain et al. [1990]. The sucrose-added emulsions showed improved stability towards coalescence, flocculation, and creaming, while the polymer-added emulsions exhibited improved stability towards coalescence but reduced stability against flocculation and creaming. A recent study showed that by using a two-step procedure, it is possible to prepare lecithin-stabilised O/W emulsions containing small cationic droplets coated with a two-layer membrane. Through conferring a polymeric outer layer to the droplets, the stability against thermal processing, freeze-thaw cycling, and high calcium ion contents as well as iron-catalysed lipid oxidation were enhanced [Ogawa et al., 2003].

2.4 Modification of soy lecithin

Commercial soy lecithin contains about 34% triglycerides. De-oiling is thus conducted to obtain lecithin with a high PL content. Acetone de-oiling is a conventional method for removing triglycerides due to the fact that triglycerides are soluble in acetone while PLs are insoluble [Wu & Wang, 2003; Vikbjerg et al., 2006]. Up to about 90% of PL-enriched lecithin can be obtained using this method. Another method for de-oiling employs a silica column with hexane solution. Separation is realised by the adsorption of neutral lipids while PLs pass through the column [Schneider, 1989]. However, de-oiling results in an increase in the PL content without changing the ratios of the PL types [Joshi et al., 2006].

Because technical soy lecithin is a complex mixture of different PLs and other substances, its properties and application depend on the composition. For example, weakly hydrophilic lecithin can be used to prepare W/O emulsions, while more hydrophilic lecithin can be used

to prepare O/W emulsions. Therefore, separation or increasing the content of individual components is of practical importance. Solvent extraction is one of the most widely used methods for the fractionation of crude lecithin due to the different solubilities of PL fractions. The efficiency of solvent extraction may vary according to the type and concentration of the solvent used and the time and temperature of the extraction. For example, ethanol and/or aqueous ethanol are used to fractionate PC and PI because PC has a higher solubility in ethanol than PI [Wu & Wang, 2003; 2004]. Both the PC- and PI-enriched fractions show a much lower critical micelle concentration (CMC) than commercial lecithin. The PI-enriched fraction has a higher surface activity than the PC-enriched fraction in terms of CMC and surface tension. This is probably due to the fact that PI contains more saturated and less unsaturated fatty acids than PC [Wu & Wang, 2003]. For W/O emulsion, it was agreed that the PI-enriched fraction is a better emulsifier than the PC-enriched fraction. For O/W emulsion, however, different conclusions were drawn [Wu & Wang, 2003; Hui, 1996]. Chromatographic separation is another way to prepare pure fractions of PLs. The drawback of this method is that a large volume of solvent is used, and thus it is cost ineffective [Teberikler et al., 2001].

With increasing health and environmental concerns regarding the use of organic solvents, the development of new technologies to fractionate lecithin without using solvents has been facilitated. Supercritical carbon dioxide (SC-CO₂) is an excellent solvent for nonpolar lipids such as triglycerides and fatty acids while PLs have limited solubility in it [Teberikler, 2001]. It has been used as an alternative to organic solvents [Nasir et al., 2007]. SC-CO₂ has shown to be very effective in removing oils from a variety of seed matrices. After de-oiling, the PLs can be extracted with SC-CO₂/ethanol [Montanari et al., 1999]. However, cost is a major concern as the processes are usually performed under high pressures and high temperatures. Manjula & Subramanian [2008] investigated the de-oiling of lecithin using a nonporous polymeric membrane and hexane as the solvent. Their results demonstrated that the membrane is a promising alternative for the de-oiling of lecithin, especially in terms of cost effectiveness.

To improve the solubility and to modify the functionality of lecithin, soy lecithin can be chemically hydrolyzed by strong acids or alkali and enzymatically hydrolyzed. Because of the difficulty of producing lecithin with controlled structures using chemical methods and properties, the enzymatic method is preferred. Two major groups of enzymes are used: phospholipases and lipases. Phospholipase A₂ is the most commonly-used phospholipase, which specifically hydrolyses the sn-2 fatty acyl group of PLs to form lyso-PLs. By using different enzymes or a combination of enzymes under different conditions, it is possible to produce hydrolysed lecithins with a wide range of properties [Nieuwenhuyzen & Tomas, 2008]. Partially hydrolysed lecithins are more hydrophilic and show enhanced O/W emulsifying properties [Nieuwenhuyzen, 1976; List, 1989]. It has been reported that the presence of divalent ions such as calcium and magnesium ions may cause a destabilisation of the emulsions. An increased resistance to these ions was observed in the emulsions prepared with hydrolysed lecithins [Nieuwenhuyzen, 1976]. Furthermore, tailored properties can be obtained by specific exchange of the acyl group in the sn-2 position of a PL, which is characterized by reacting the PL with a free fatty acid in the presence of phospholipase A₂ [Pedersen, 2001]. PC structures synthesised by enzymatically exchanging the long chain fatty acids with medium chain fatty acids are more hydrophilic and are thus better emulsifiers for O/W emulsions [Vikbjerg et al., 2006].

Lecithin can also be modified by hydrogenation, which involves the reaction of PLs with hydrogen gas in the presence of a catalyst to add hydrogen to the unsaturated fatty acids [Lantz, 1989]. Hydrogenated lecithins show greater oxidative stabilities and higher melting

points but lower solubilities in oils and fats [Nieuwenhuyzen, 2010]. They are used in chocolate formulations and emulsions for intravenous injections [List, 1989]. Another way to modify lecithin is by hydroxylation, which is carried out by the reaction of lecithin with hydrogen peroxide and lactic acid or a peracid to form hydroxyl groups in the unsaturated fatty acid chains. The amino group of the PE can also be modified [Nieuwenhuyzen, 1981; List, 1989]. The O/W emulsifying properties of hydroxylated lecithins are significantly improved as a result of the enhanced water dispersibility [Nieuwenhuyzen, 1981]. Hydroxylated lecithin has GRAS (generally recognised as safe) status (21 CFR 172.814) in the USA, but it is not listed in the EU Food Additive Directive [Nieuwenhuyzen, 1998]. Acetylation of the head group of the phospholipids, primarily the amino group of PE, is a well-used method for modifying the structure and property of PLs [Nasir et al., 2007]. Soy lecithin can be acetylated by chemical methods using acylating agents such as acetic anhydride. However, chemical acetylation suffers several drawbacks, including incomplete and non-selective acetylation and the formation of decomposition products that result in dark-coloured reaction products. Enzymatic acetylation is, therefore, employed to selectively acetylate the amino group of PE [Marellapudi et al., 2002]. Acetylated lecithins exhibited improved fluidity, solubility, and resistance to heat and darkening. The enhanced emulsifying property makes them effective emulsifiers for O/W emulsions [Dashill & William, 1984; Marellapudi et al., 2002; Nasir et al., 2007].

2.5 Applications of soy lecithins

Soy lecithin is highly valued because of its natural origin, abundant supply and multiple functionalities. Its safety has been confirmed by the World Health Organization [WHO, 1974]. It is one of the few emulsifiers that have been awarded GRAS status by the US Food and Drug Administration FDA. Standard lecithin, fractions, and acetylated lecithin are listed in 21CFR184.1400; enzyme-modified lecithin in 21CFR184.1063; and hydroxylated lecithin in 21CFR172.814 [Nieuwenhuyzen, 2010]. Native soy lecithins and modified soy lecithins are important emulsifiers and stabilisers in the production of emulsion, foam/bubble products and others, and thus have found applications in various industries where these products are used. Currently, the most used lecithins in the food industry are soy lecithins, with a use level of about 0.1% to 2%. They are often used in combination with synthetic surfactants to reduce the amount of the synthetic surfactants [Rust & Wildes, 2008]. In the food industry, the deoiled lecithin is preferred over purified PLs due to cost considerations [Vikbjerg et al., 2006]. Lecithins are added to food products to improve their quality and shelf life. For example, lecithin provides significant reduction in the viscosity of chocolates and coatings [Weyland & Hartel, 2008]. In margarine, lecithin plays an important role in anti-spattering by stabilising the water droplets. The addition of lecithin enhances the volume and freshness of baked goods [Nieuwenhuyzen & Tomas, 2008]. Lecithin is also used as a food supplement to improve cardiovascular health as well as to enhance memory and physical endurance [Nieuwenhuyzen & Tomas, 2008].

As amphiphilic molecules, PLs may form micelles, liposomes, bilayer sheets, lamellar structures, or organogel in aqueous solutions according to the concentration, hydration, and temperature. These self-assembling systems are potential delivery systems for active ingredients and drugs. Purified fractions and modified PLs are often utilised in these areas. Extensive research has been conducted on the use of these self-assembling systems to deliver drugs and genes and to treat diseases and cancers, which is beyond the scope of this chapter. In the food industry, liposomal nanoencapsules have been used as controlled

delivery systems for products such as nutraceuticals, enzymes, vitamins, flavours, pesticides, and antimicrobials. The use of these nanoencapsules shortens the processing time of cheese products, fortifies the nutritional quality of dairy products, prevents the degradation of food components, and improves the safety of food products [Taylor et al., 2005].

3. Soy protein

3.1 Soy proteins and their structural and functional properties

The protein content of soybean seeds is about 40%. It is known that the main soy proteins are globulins that can be classified into 2S, 7S, 11S, and 15S fractions according to their sedimentation rates during centrifugation. The 7S (β -conglycinin) and 11S (glycinin) fractions are the major components of soy proteins, accounting for about 40% and 30% of the total seed proteins, respectively. Their contents vary with soybean variety and environment [Iwabuchi & Yamauchi, 1987; McSweeney, 2008; Mujoo et al., 2003]. The amount of 7S and 11S proteins in soy protein products depends on the extraction method and thus affects the functional properties of the soy protein products. The 7S protein is a trimer consisting of α' , α , and β subunits with a molecular weight of approximately 200,000. The 11S protein consists of six subunits, each made up of an acidic polypeptide chain linked by disulfide bonding to a specific basic polypeptide chain with molecular masses of approximately 330,000 [Mujoo et al., 2003]. It has been reported that the 7S globulin has a higher functionality (e.g., solubility and emulsification) than the 11S globulin, which is attributed to the relatively stable oligomeric structure of the 11S globulin [Chove, 2007].

Soy proteins are obtained after the extraction of soybean oil. After the hulls and the oil are removed, the remaining defatted flake has a protein content of approximately 50% [Endres, 2001]. Soy proteins are available in three major forms based on protein content: soy flours, soy protein concentrates and soy protein isolates. Soy flours are the least refined forms of soy protein products containing 50-59% protein. Soy flours are obtained by grinding defatted soy flakes and may vary in fat content, particle size, and degree of heat treatment. The functionality of soy flours is related to their capacity to bind water and absorb fat. In general, lower heat treatment and smaller particle size means more functionality [Endres, 2001; Lai & Lin, 2006]. Soy protein concentrates are obtained by aqueous liquid extraction or an acid leaching process and contain 65-72% protein. Non-proteic constituents (mainly soluble minerals), carbohydrates, low molecular weight nitrogen compounds and antinutritive factors are removed from defatted meal [Moure et al., 2006]. Soy protein concentrates with different properties can be produced by using different extraction methods or solvents. Compared to soy flours, soy protein concentrates have improved flavour characteristics. The major functionalities of soy protein concentrates are emulsification, water and fat absorption, viscosity control, and texture control [Endres, 2001]. Soy protein isolates are the most refined forms of soy proteins and contain 90% protein. They are obtained by aqueous or mild alkali extraction followed by isoelectric precipitation. Sugars and other water-soluble materials as well as cotyledon fibres are removed [Park et al., 2002; Endres, 2001]. Membrane technology has been reported to be effective in the preparation of soy protein isolates. Compared to the protein products prepared by isoelectric precipitation, the obtained protein products showed improved functional properties, especially the emulsifying properties [Moure et al., 2006]. Soy protein isolates provide diverse functionalities that enable them to modify the physical properties of

food products. Neutralised isolates are usually highly soluble. They possess both emulsifying and emulsion-stabilising properties. They are excellent binders of fat and water, and they are good adhesive agents. They vary mainly in their dispersibility, gelling, and viscosity characteristics [Endres, 2001]. The characteristics of soy proteins depend on the method of preparation and on processing conditions such as pH, ionic strength, and temperature.

Soy proteins are important natural polymeric emulsifiers that have been used in various applications. During emulsification, soy proteins adsorb to the newly formed interfaces to facilitate the formation of emulsions. Proteins having a more flexible structure can be more efficient in orienting their hydrophobic segments towards the oil phase and the hydrophilic segments towards the aqueous phase, and thus have a higher emulsifying activity. Consequently, the emulsifying properties of soy proteins are governed by their dispersibilities, surface hydrophobilities and conformational mobilities. The extent of unfolding depends on the available surface area, the amount of time spent in contact with the interface, and the macromolecular structure prior to adsorption [Dickinson, 1993; Molina et al., 2001]. After adsorption at the interface, proteins form a thick interfacial layer to stabilise the emulsion.

The foaming properties of soy proteins have been widely studied [Foegeding et al., 2006; Kinsella, 1976; Vani & Zayas, 1995; Ortiz & Wagner, 2002; Chove, 2007]. It has been reported that a high dispersibility of the protein is required for the formation of foam, while the unfolding of the proteins at the interface governs the stability of foam. Hence, the solubility of soy proteins greatly influences the foaming property but not the foam stabilisation property [Foegeding et al., 2006; Liu, 1997; Kinsella, 1976]. Therefore, proteins with high foaming abilities do not necessarily result in high foam stabilisation abilities and vice versa [Vani & Zayas, 1995]. Foam formation is also affected by the size of the proteins, which is related to the migration and adsorption of the proteins at the interface [Ortiz & Wagner, 2002].

For a surface-active molecule to be a good surfactant, it must be capable of rapid adsorption at the air-water or oil-water interface to reduce the surface or interfacial tension. In this regard, low molecular weight surfactants (e.g., lecithin) are more effective than high molecular weight surfactants (e.g., proteins). Proteins, however, are more effective in conferring stability on emulsions and foams than low molecular weight surfactants. The stability of protein-stabilised emulsions and foams is determined by the properties of the interfacial adsorbed layer such as the surface coverage, the layer thickness, and the surface charge density, which are affected in turn by the aqueous solution conditions, for example, pH, ionic strength and the presence of other ingredients [Dickinson, 2003].

3.2 Use of soy proteins in combination with other additives

Most soy protein-containing products are multi-component systems. In some cases, proteins alone cannot provide desirable functionality so other ingredients are added to achieve the desired functionality. The functional properties of proteins can be improved by using proteins in combination with other additives. A synergistic effect between soy protein and casein was reported in which the loops of caseins protrude into the aqueous phase to provide steric stability while the globular soy protein may contribute viscoelasticity. The composition and structure of the interfacial film may be affected by the ratio of soy protein and casein caused by the competitive adsorption between the two proteins [Damodaran, 2005]. The competitive adsorption between the proteins is much more complicated than that

between a protein and a low molecular weight surfactant due to the slower adsorption and greater energy needed for desorption [Murry, 2007].

Special focus has been given to improving the functionality of soy proteins by constructing protein-PL or protein-polysaccharide complexes [Dickinson, 1993]. When proteins co-exist with low molecular weight surfactants in a dispersed system (e.g., emulsion and foam), competitive adsorption between proteins and low molecular weight surfactants occurs, resulting in a reduction in the amount of adsorbed protein. Above a critical surfactant concentration, complete displacement of protein molecules may take place, depending on the nature of the surfactants and the oil phase (Dickinson & Tanai, 1992). As a result, the composition, structure, and property of the interface layer may be changed, which in turn affect the property and stability of the dispersed system.

The combination of lecithin and protein may have a synergistic effect or an antagonistic effect on the stability of dispersed systems due to the displacement of protein from the interface by lecithin. Interactions between proteins and PLs may cause changes in surface activity, protein structure, molecular flexibility, and net charge and may lead to the incorporation of protein into surfactant micelles or vesicles [Nieuwenhuyzen & Szuhaj, 1998]. Scuriatti et al. [2003] described that the emulsions prepared with the addition of PC exhibited improved stabilities against creaming and mechanical stirring compared to the emulsions prepared with native soy protein isolates (NSI) alone. The addition of sodium chloride was found to destabilise the NSI-PC-stabilized emulsions. A lesser degree of destabilisation was observed in the emulsions prepared with denatured soy protein isolates (DSI) and PC, suggesting stronger interactions between the denatured protein and PC. A recent study by Comas et al. [2006] showed that the presence of soy lecithin enhanced the emulsion stability of a DSI system at all pH values studied (2.0, 5.5, and 6.2), while it enhanced NSI stability only at pH 2.0. Lecithin is likely to contribute to surface charges rather than to an increase in the surface activity. Heat treatment of a soy protein isolate–lecithin mixture reportedly led to an enhancement in the emulsification activity, mainly due to the denaturation of the 11S globulin [Hirotsuka et al., 1984]. Differences between NSI–lecithin and DSI–lecithin systems are thus thought to be caused by the differences in protein structure and charge property.

Proteins and polysaccharides are two major biopolymers that contribute greatly to the stability and rheology of food colloids. In dispersed systems, proteins can act as emulsifying/foaming agents and stabilisers by adsorbing at the air-water or oil-water interface and forming a protective interfacial layer, while polysaccharides mainly act as stabilizers through their thickening and gelling behaviour [Dickinson & Galazka, 1991]. A better understanding of soy protein-polysaccharide interactions is critical to the prediction and the control of the stability of foods. Therefore, many studies have been conducted on the interactions between protein and polysaccharide and the effect of protein-polysaccharide complexes on the formation and stabilisation of emulsion systems. Interactions between proteins and polysaccharides may lead to changes in surface activities and thicknesses of the interfacial layers and thus have an impact on the stability of emulsions [Dickinson, 1993].

Pectin is an acidic polysaccharide mainly extracted from apples and citrus fruits. It is one of the most commonly used polysaccharides in acidic environments and has been used as a gelling agent, thickening agent, and stabiliser in food. Soy soluble polysaccharide (SSPS) is extracted from soybean cotyledons and often used in acidic emulsion-based beverages. A study performed by Roudsari et al. [2006] revealed that SSPS exhibited a different

stabilization behavior from that of high methoxyl pectin (HMP) in the emulsions prepared with soy protein isolates. At a neutral pH and above a critical stabiliser concentration (0.05%), HMP caused flocculation of the emulsion droplets via a depletion mechanism while no creaming or flocculation was observed in the emulsions prepared with SSPS. At an acidic pH (<4.0) the addition of pectin caused extensive droplet aggregation, while no aggregation was observed with the addition of SSPS. The different stabilisation behaviours between the two polysaccharides can be attributed to their differences in charges, neutral sugar side chains, and molecular weights.

By comparing the formation and stability of emulsions prepared with β -lactoglobulin, a β -lactoglobulin-dextran mixture and a dry-heated β -lactoglobulin-dextran composite, Dickinson & Galazka [1991] concluded that dry-heat treatment enhances the functionality of protein-polysaccharide hybrids. Dry-heat treatment yields a β -lactoglobulin-dextran complex containing a covalent Maillard-type linkage between the two biopolymers and produces emulsions with excellent stability with respect to creaming, coalescence, and serum separation. In contrast, emulsions prepared with an unheated protein-polysaccharide mixture showed poorer stability than those prepared with protein alone due to the depletion flocculation caused by the presence of unadsorbed polysaccharides. Diftis & Kiosseoglou [2004] demonstrated that stable O/W emulsions can be prepared by a dry-heated SPI-dextran composite. Two factors appear to contribute to the stability of the emulsions. One is that the SPI-dextran conjugate forms a thick interfacial membrane providing steric stabilisation to the emulsions, and the other factor is that the SPI-dextran conjugate changes the effective density of the oil droplets and therefore slows down the creaming of the emulsions [Diftis & Kiosseoglou, 2004].

As mentioned above, the presence of low-molecular-weight surfactants may cause the displacement of proteins from the interface. It has been proven in a corn oil-water emulsion system that dry-heated SPI-dextran mixtures have improved abilities against competitive adsorption. The presence of low-molecular-weight surfactants (Tween 40) in the emulsions stabilised by a dry-heated SPI-dextran mixture led to competitive adsorption between the protein and low-molecular surfactants, resulting in a decrease in the amount of soy protein adsorbed at oil droplet surfaces. However, complete displacement did not occur, and a significant amount of protein-dextran conjugate still remained at the interface, conferring stability to the emulsion even at a surfactant-protein weight ratio of as high as 2. The presence of Tween 40 did not influence the creaming stability of the emulsions. Glycerol monostearate, however, caused the destabilisation of the emulsions [Diftis & Kiosseoglou, 2004]. The presence of bovine serum albumin (BSA), a well-characterised protein, resulted in the partial displacement of soy protein but had no effect on the creaming stability of the emulsions.

3.3 Modification of soy proteins

The functionalities of soy proteins depend strongly on their three-dimensional structures, hydrophobicities, charges, and solubilities. However, the solubility of soy proteins in aqueous solutions significantly decreases as the pH decreases to about 5.0, which is the typical pH range for many food emulsions [McEvily & Zaks, 1991]. Furthermore, the globular structure of soy proteins prevents them from sufficiently unfolding and rearranging at the oil-water interface [Roesch & Corredig, 2003], preventing soy proteins from being more effective in reducing interfacial tension. Currently, soy proteins are used as the starting materials for the production of surfactants [Rust & Wildes, 2008]. Various physical (heat or mild alkali

treatments), chemical (acylation, alkylation, oxidation, phosphorylation, and deamidation, etc.) and enzymatic (transglutaminase, protease, and peptidoglutaminase) methods have been employed to modify the physico-chemical properties and nutritional value of soy proteins [Hamada, 1992, Molina, 2001, Moure, 2006]. Chemical approaches have several drawbacks, such as the lack of specificity and the loss of nutritional value. Hence, enzymatic hydrolysis is the most widely used method for the modification of soy proteins. It has been demonstrated that enzymatic deamidation improved the solubilities, emulsifying activities, emulsion stabilities, and foaming properties of soy protein hydrolysates [Hamada & Marshall, 1989]. Hydrolysed soy proteins are important ingredients for food products.

When proteins are subjected to high pressures, their secondary, tertiary and quaternary structures may be changed, which may lead to changes in the functional properties of the proteins. Several studies have been performed on the utilisation of high pressure to modify the functional properties of soy proteins [Kajiyama et al., 1995; Molina et al., 2001]. High-pressure treatment at neutral pH can improve the emulsifying activity of soy proteins but does not improve their emulsifying stabilities and solubilities [Molina et al., 2001].

It is known that ultrasound is an energy- and time-efficient approach. The interest in the application of ultrasound in various industries is increasing. A recent study indicated that the functional properties of soy proteins can be modified by ultrasound treatment in terms of increased solubility, specific surface area, and emulsion activity index [Jambrak, 2009]. The improvement in the emulsifying property is likely to be the result of the partial denaturation of soy proteins during ultrasound treatment, which facilitated the adsorption of the proteins at the oil-water interface.

3.4 Applications of soy proteins

Extensive studies have shown that soy protein products are excellent sources of protein and offer multiple health benefits. In October 1999, the US FDA approved a health claim for soy protein, stating that the consumption of at least 25 g of soy protein per day may reduce the risk of heart disease. Since then, soy protein has received increased attention. Currently, soy proteins have been used as nutritional and functional ingredients in every food category. Aside from their nutritional value, soy proteins affect the appearance, colour, flavour, taste, and texture of food products [Endres, 2001]. The nutritional aspects of soy proteins have been documented in numerous studies, which is beyond the scope of this chapter. Here, we briefly review some of the applications using soy proteins as surfactants.

In baked products, the addition of soy proteins improves the crust colour, grain, texture, and shelf life of products through improving the emulsification of fats and other ingredients. Soy protein concentrates and isolates are often used in the production of dairy products. Soy protein isolates can be used in emulsified products such as coffee whiteners, liquid whipped toppings, and pre-whipped toppings [Endres, 2001]. For coffee whiteners, the primary function of the protein is to assist in the formation and stabilisation of emulsions, especially when added to coffee. Fats with low melting points were found to interact with the protein to form stable emulsions. For whipped toppings, soy protein isolates help in the formation of emulsions and in the incorporation of air during whipping. In most whipped topping formulations, soy protein isolates are used at a lower level than sodium caseinate (or to replace sodium caseinate) because of their higher viscosities and excellent emulsifying properties. These products are popular because of their low cost and convenience in handling and storage [Kolar et al., 1979]. Soy protein hydrolysates have

found applications in the production of confections, desserts, toppings, and beverages because of their low molecular weight, increased solubility, and good foaming properties. The production of processed meat products has become a major area for the use of soy proteins. Soy proteins act as binders, emulsifiers, and meat flavour enhancers. Recently, the substitution of animal proteins with vegetable proteins has attracted increasingly attention as a result of the increasing public interest in health. Soy proteins have been added to food products as a substitute for animal proteins. In emulsified meat products (e.g., frankfurters, bologna, and sausage), soy protein concentrates and isolates are added to improve the water and fat binding capacities, emulsification, and stability of the products. The products are excellent in taste, appearance, and flavour [Endres, 2001].

4. Soybean oil-based biosurfactants

4.1 Production of soybean oil-based surfactants

As stated previously, surfactants can be produced from oleochemical or petrochemical sources. The use of petrochemicals as the raw materials for the production of surfactants dates back to the first half of the 20th century and is attributed to the rapid development of the petrochemical industry, which made petrochemical products available [Karsa & Houston, 2006]. The concerns over the supply, price and environmental impact of petrochemicals greatly stimulate the use of safer, cost-effective, eco-friendly, biodegradable, naturally-based surfactants to replace petrochemical surfactants. The basic oleochemical feedstocks are plant oils and animal fats. The use of beef tallow has been reduced due to bovine spongiform encephalopathy (BSE) concerns. The primary plant oils are coconut, palm, castor, rapeseed, and soybean oils, with the majority being coconut and palm oil [Karsa & Houston, 2006].

Soybean oil is the world's second largest source of vegetable oil and dominates the world vegetable oil economy. It is currently the second most consumed edible oil in the world because of its nutritional value, availability, low cost, and wide functionality. The consumption of soybean oil in the world in 2009 was 35.7 million metric tons, about 28% of the world vegetable oil consumption [American Soybean Association, 2010]. The growth in soybean oil production and the decline in dietary oil consumption due to health concerns have accelerated the development of non-food applications of soybean oil. Soybean oil has been used as a raw material to produce various products ranging from lubricants, plasticizers, painting inks, coatings, biofuels and surfactants [Guo et al., 2007].

For surfactant production, soybean oil is used as a fermentation substrate or a raw material. Surfactants can be produced by various microorganisms using soybean oil or oil wastes as the substrates. Different types of biosurfactants (e.g., rhamnolipid, sophorolipid and mannosylerythritol lipid) have been produced [Muthusamy et al., 2008]. Currently, soybean oil is the predominate feedstock used in the manufacture of soybean-based surfactants [Rust & Wildes, 2008]. Soybean oil is a mixture of triglycerides consisting of low saturated fat (15%) and high unsaturated fat (61% polyunsaturated, 24% monounsaturated). Efforts to exploit new applications of soybean oil have been made to improve its reactivity through modification. Triglycerides contain two reactive sites: the double bond in the unsaturated fatty acid chain and the carboxylic ester group linking the fatty acid to the glycerol (Fig. 2). The transesterification reaction between the ester group of the triglyceride and an alcohol is an important reaction for biodiesel production. Attentions have been directed to modifying soybean oil by converting its double bonds to more reactive groups. Epoxidation is a commonly used method for this purpose. The double bonds are converted into more reactive

epoxide or oxirane ring groups by reacting with peracids or peroxides. The benefits of epoxidised soybean oil (ESO) include its low toxicity, low irritancy, and lack of carcinogenic or non-genotoxic effects (BIBRA, 1988; EFSA, 2004). ESO is a promising intermediate for the production of a variety of soybean oil-based products and is commercially available. Different methods have been employed to modify ESO. The ring-opening reaction is the most predominant reaction for ESO modification. The ring-opening hydrolysis of ESO results in the formation of soy-polyols, depending upon the oxirane content and the extent of hydrolysis. Soy polyols have found applications in a variety of fields such as surfactants and coatings [Guo et al., 2007]. Soy polyols prepared by ring opening reactions of ESO with hydrogen active compounds can be ethoxylated to improve their properties. The obtained ethoxylated soybean polyols have higher hydrophilicities and better compatibilities with water. They can be used as surfactants to prepare foams [Lee et al., 2010].

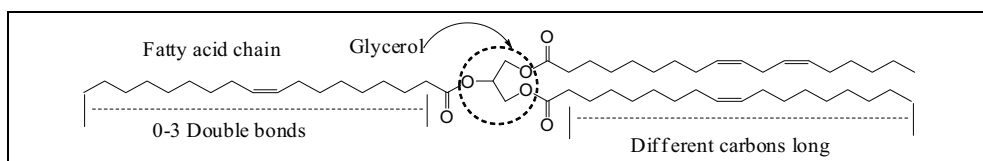

Fig. 2. The structure of soybean oil.

Polymeric surfactants can also be synthesised from ESO through a two-step procedure. Figure 3 depicts the synthesis of a soybean oil-based polymeric surfactant. The oxirane moiety of ESO was opened in methylene chloride or a benign media such as ethyl acetate

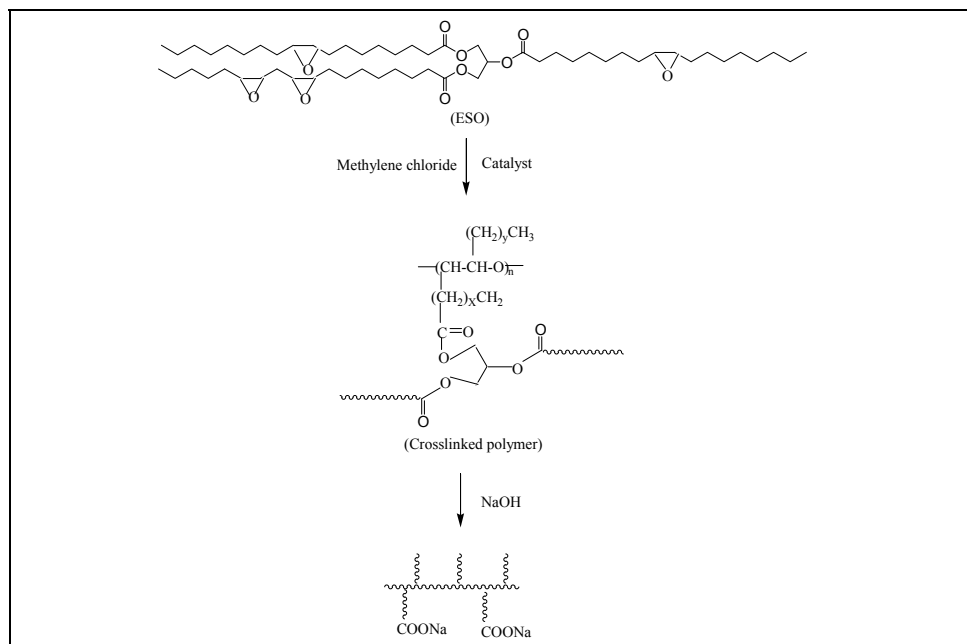

Fig. 3. The synthesis of Palozengs R-004.

using a cationic initiator ($\text{BF}_3 \cdot \text{OEt}_2$). The resulting polymer was hydrolysed with a base to remove the glycerin backbone from the oil structure and obtain a polymer with free carboxylic acid groups. The resulting polyacid was then converted into polysoap by neutralising it with an appropriate base (NaOH) [Biresaw et al., 2008; Liu & Erhan, 2010]. Recently, efforts have been paid to the preparation of ESO-derived surfactants using the environmentally-friendly solvent SC-CO_2 , targeting applications in food, pharmaceutical delivery, and cosmetics. Polymers prepared by this method possess advantageous properties compared to that obtained by other methods.

Because the conventional methods for surfactant production are governed by several parameters, it is time-consuming to produce surfactants with desired properties through the trial and error approach. Also, some organic solvents are used. This may limit their application in food and medical areas. An attempt has been made to use computer-aided molecular design (CAMD) to address this challenge. Soybean oil-derived surfactants have been designed by taking into account important properties such as the hydrophilic-lipophilic balance, the CMC, surface tension, and wetting time. The results suggest that the structures obtained from the CAMD methodology are useful for the synthesis of surfactants with novel functionalities [Camarda & Sunderesan, 2005].

4.2 Properties of soybean oil-based surfactants

Surface activity is a key parameter in the evaluation of the ability of a surfactant to reduce surface tension and to stabilise newly created surfaces. The surface activity of soybean oil-based surfactants is comparable to the reported activities of microbial surfactants [Cox et al., 2007; Lee et al., 2008] and higher than those of some of the conventional synthetic surfactants [Xu et al., 2009]. The surface tension of Milli-Q water was reduced to a minimum value of less than 30 mN/m. The surface activity was found to be affected by the type of counter ion and molecular weight [Biresaw et al., 2008]. An ESO-derived surfactant, Palozengs (R-004), exhibited a unique aggregation behaviour and formed small aggregates (sub-micelles or pre-micelles) at very low concentrations. A further increase in concentration resulted in an increase in aggregate size and polydispersity. Monomers and aggregates with different sizes may coexist in surfactant systems. It is generally assumed that aggregation takes place at the CMC or critical aggregation concentration (CAC). The physico-chemical properties of a surfactant change markedly above and below the CMC. Hence, the CMC is an important parameter for evaluating surfactants and for the selection of a suitable surfactant and the optimum surfactant concentration in practical applications. Normally, a surfactant concentration higher than the CMC is needed to effectively prepare dispersed systems. The CMC can be determined by measuring the changes in physical properties such as electrical conductivity, turbidity, surface tension, and interfacial tension. Among these methods, the surface tension method is the most commonly used method. The breakpoint in the surface tension-surfactant concentration curve is generally referred to as the CMC. In the case of R-004, however, it was found that the CMC or CAC determined by the surface tension method may not accurately represent the concentration at which aggregation starts. The formation of sub-micelles has also been reported in casein [Koczo et al., 1996], SC3 hydrophobin [Corvis et al., 2006] and low molecular weight versus such as SDS [Cui et al., 2008]. In these cases, the CMC obtained from the adsorption isotherm may correspond to saturation of the interface. The inflection in the plot of surface tension versus concentration was defined as the surface saturated concentration (SSC) rather than as the CMC or CAC [Cox et al., 2007]. Zeta-potential measurements confirmed that R-004 is an anionic surfactant

due to the presence of carboxylic groups. The absolute value of the zeta-potential greatly increased with increasing R-004 concentration, suggesting an increase in aggregation number and surface charge density [Xu et al., 2010].

4.3 Applications of soybean oil-based surfactants

Wong et al. [2006] used a soybean oil-based surfactant to fabricate solid lipid nanoparticles for the delivery of an anticancer drug, doxorubicin hydrochloride (Dox). The obtained nanoparticles had a size range of 80-350 nm with a drug encapsulation efficiency of 60-80%. It was found that about 50% of the loaded drug was released in the first few hours, and an additional 10-20% was released within two weeks. An enhancement in cytotoxicity was confirmed, suggesting a potential application in drug delivery and cancer treatment. The hydrogels formed by soybean oil-based polymers exhibited viscoelastic solid or gel behaviour at concentrations above 2% (wt. %) at room temperature. The hydrogels possess attractive properties for applications in the encapsulation of drugs, functional compounds, and cells [Xu et al., 2008a].

Along with the dispersed systems mentioned above, bubble dispersion is an important dispersed system. Bubbles are ubiquitously present in biological systems and in industrial and agricultural products. Bubbles can be divided into two types according to their morphology: well-separated spherical bubbles and interlinked polyhedral bubbles. The former are referred to as bubbles while the latter are referred to as foams [Xu et al., 2008b]. Numerous studies have been performed on the use of microbubbles as ultrasound contrast agents [Wheatley et al., 2006] and as delivery systems for drugs and genes [Tsutsui et al., 2004]. The application of microbubbles has been extended to aquaculture, hydroponic cultivation, water purification, and sewage treatment [Onari, 2005; Takahashi, 2005]. Although promising results have shown the great potential of micro-/nanobubble-based technology, the lack of well-established generation and characterization methods remains a major challenge in understanding the properties of micro-/nanobubbles and their applications. Xu et al. [2008b] revealed that the properties of microbubbles depend on their generation method and the surfactant used. An important property of microbubbles that distinguishes them from the conventional large bubbles is that they shrink when their size is below a critical value. The rate of shrinkage significantly increases with a decrease in the size of microbubbles due to an increased internal pressure. Therefore, it is technically and theoretically difficult to prepare tiny bubbles and even more difficult to stabilise them [Xu et al., 2008b; 2009]. Regardless of their difficulty in preparation and stabilisation, micro-/nanobubbles are gaining more interest from both fundamental and applied points of view. The ability of the soybean oil-based surfactant R-004 to form and stabilise microbubbles was evaluated by measuring the size distribution and changes in the average bubble size over time. No obvious differences in size distribution and average bubble size were found between the concentrations below and above the SSC, suggesting the high efficiency of R-004 in bubble preparation and the possibility to produce microbubbles with a lesser amount of surfactant. The bubble dispersions were separated into two distinct layers within minutes after preparation: the milky upper layer and clear lower layer. The upper layer contained larger microbubbles with diameters that increased with time. The height of the upper layer decreased with time and finally disappeared. On the other hand, the clear lower layer contained stable tiny bubbles (Fig. 4). It was proposed that the hydrophobic moiety of the R-004 molecule conferred a substantial degree of hydrophobicity to R-004, allowing it to strongly adsorb at the bubble surface and form a protective adsorbed layer to stabilise the

bubbles. Moreover, the polyelectrolytic properties of R-004 contributed to the electrostatic stabilisation of the bubbles.

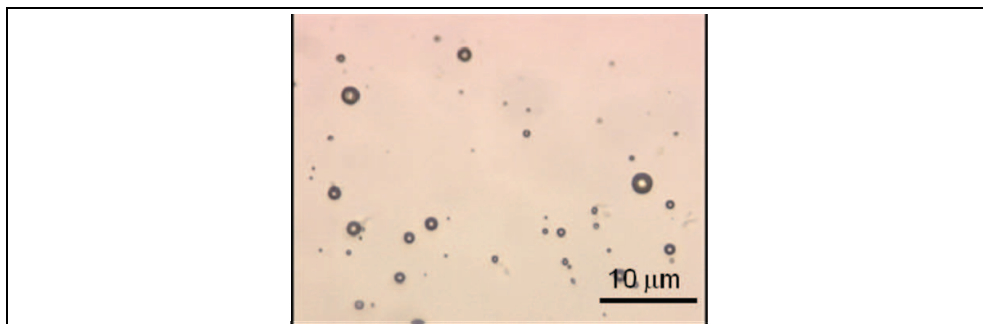

Fig. 4. Bubbles prepared with 0.1% filtered R-004 (one day after sonication).

The obtained results have revealed that soybean oil-based surfactants possess unique and interesting properties. They have several advantages over conventional synthetic surfactants, such as high surface activities, biodegradability, biocompatibility, and cost-effectiveness [Wong et al., 2006; Xu et al., 2008a]. The formation and stabilisation of microbubbles are affected by the characteristics of R-004 aggregates [Xu et al., 2010], suggesting the importance of investigating the relationship between the structure and function of the surfactants. Unlike soy lecithins and soy proteins, it may be said that the production and utilisation of soybean oil-based surfactants are just at the initial phases. Because the functionalities of surfactants are dependent on their solubilities, charges, sizes, degrees of polymerisation, an understanding of the effect of the production conditions on the properties of soybean oil-based surfactants is necessary to produce surfactants with desired functionalities. Further study is required to investigate the effects of factors such as pH and the type and concentration of electrolytes on the surfactant aggregation as well as on the formation and stabilisation of dispersed systems. Soybean oil-based surfactants have shown a potential for their application in the food, pharmaceutical, and cosmetic industries. To improve the functionalities of soybean oil-based surfactants and the quality of products, the elucidation of the interactions between the soybean oil-based surfactants and low molecular weight surfactants, proteins, polysaccharides, and other components is thus becoming an important research priority.

5. Conclusions

There is a considerable amount of literature devoted to the nutritional functionality and health benefits of soybeans. In this chapter, we focus on the surfactants from soybeans, which have been widely used in various industries, including the food, cosmetic, and pharmaceutical industries. It can be expected that the demand for the production of soybean-based surfactants will continue to increase. Currently, a number of technologies are available for modifying soybean-derived surfactants to achieve improved functionalities. The major challenge for the future is to produce surfactants with tailored structures and properties. For this purpose, a better understanding of the relationship between the structure and functionality of the surfactants is necessary. Compared with soy lecithins and

soy proteins, the production and utilisation of soybean oil-derived surfactants are still in the early stages. Recent studies on these surfactants were introduced with an emphasis on the preparation of microbubbles. Although a great potential for the application of soybean oil-derived surfactants has been shown, further investigation into the characterisation of their properties is required to fully exploit their functionalities. In addition, it is scientifically and practically important to elucidate the mechanisms of formation and stabilisation in various dispersed systems. The combination of soybean oil-derived surfactants and low molecular weight surfactants, proteins, or polymers will be a challenge in extending their applications to new fields.

6. Acknowledgment

This research was financially supported by the Food Nanotechnology Project of the Ministry of Agriculture, Forestry and Fisheries of Japan.

7. References

- Acmite market intelligence (2008), *World surfactant market: markets, products, applications, innovations, chances & risks, competition, prospects to 2015*. Ratingen.
- Angelico, R.; Ceglie, A.; Colafemmina, G.; Delfino, F.; Olsson, U. & Palazzo, G. (2004). Phase Behavior of the Lecithin/Water/Isocetane and Lecithin/Water/Decane Systems, *Langmuir*, Vol. 20, No. 2, 619-631, ISSN: 0743-7463.
- American Soybean Association (2010). <http://soystats.com/2010/Default-frames.htm>.
- BIBRA (The British Industrial Biological Research Association) (1988). Toxicity profile: epoxidised soy bean oil, Carlshalton.
- Biresaw, G.; Liu, Z. & Erhan, S.Z. (2008). Investigation of the surface properties of polymeric soaps obtained by ring-opening polymerization of epoxidized soybean oil. *J. Appl. Polym. Sci.*, Vol. 108, No. 3, 1976-1985, ISSN: 0021-8995.
- Boode, K.; Bisperink, C. & Walstra, P. (1991). Destabilization of O/W emulsions containing fat crystals by temperature cycling, *Colloids and Surfaces*, Vol. 61, December, 55-74.
- Camarda, K. V. & Sunderesan, P. (2005). An Optimization Approach to the Design of Value-Added Soybean Oil Products, *Ind. Eng. Chem. Res.*, Vol. 44, No. 12, 4361-4367, ISSN: 0888-5885.
- Castelain, C.; Renard, D.; Bronnec, I. & Laroche, M. (1990). Stability of lecithin-stabilized emulsions in the presence of sucrose or hydroxyethylcellulose, *Food Hydrocolloids*, Vol. 4, No. 3, 205-214, ISSN: 0268-005X.
- Chove, B. E.; Grandison, A. S. & Lewis, M. J. (2007). Some functional properties of fractionated soy protein isolates obtained by microfiltration, *Food Hydrocolloids*, Vol. 21, No. 8, 1379-1388, ISSN: 0268-005X.
- Cirelli, A. F.; Ojeda, C.; Castro, M. J. L. & Salgot, M. (2008). Surfactants in sludge-amended agricultural soils, *Environ. Chem. Lett.* Vol. 6, No. 3, 135-148, ISSN: 1610-3653.
- Comas, D. I.; Wagner, J. R. & Tomás, M. C. (2006). Creaming stability of oil in water (O/W) emulsions: Influence of pH on soybean protein-lecithin interaction, *Food Hydrocolloids*, Vol. 20, No. 7, 990-996, ISSN: 0268-005X.
- Corvis, Y.; Brezesinski, G.; Rink, R.; Walcarius, A.; Heyden, A. V. D.; Mutelet, F. & Rogalska, E. (2006). Analytical Investigation of the Interactions between SC3 Hydrophobin

- and Lipid Layers: Elaborating of Nanostructured Matrixes for Immobilizing Redox Systems, *Anal. Chem.*, Vol. 78, No. 14, 4850-4864, ISSN: 0003-2700.
- Cox, A. R.; Cagnol, F.; Russell, A. B. & Izzard, M. J. (2007). Surface Properties of Class II Hydrophobins from *Trichoderma reesei* and Influence on Bubble Stability, *Langmuir*, Vol. 23, No. 15, 7995-8002, ISSN: 0743-7463.
- Crujisen, J. M. M. (1996). Physical stability of caseinate - stabilized emulsions during heating, Ph.D. Thesis, Agricultural University, Wageningen, The Netherlands.
- Cui, X.; Mao, S.; Liu, M.; Yuan, H. & Du, Y. (2008). Mechanism of Surfactant Micelle Formation, *Langmuir*, Vol. 24, No. 19, 10771-10775, ISSN: 0743-7463.
- Damodaran, S. (2005). Protein Stabilization of Emulsions and Foams, *J. Food Sci.*, Vol. 70, No. 3, R54-66, ISSN: 0022-1147.
- Dashiell, G. L. & Prosis, W. E. (1984). Method of preparing heat resistant lecithin release agent, United States Patent 4479977.
- Dickinson, E. & Galazka, V. B. (1991). Emulsion stabilization by ionic and covalent complexes of β -lactoglobulin with polysaccharides, *Food Hydrocolloids*, Vol. 5, No. 3, 281-296, ISSN: 0268-005X.
- Dickinson, E. (1993). Towards more natural emulsifiers, *Trends Food Sci. Tech.*, Vol. 4, No. 10, 330-334, ISSN: 0924-2244.
- Dickinson, E. & Tanai, S. (1992). Protein Displacement from the Emulsion Droplet Surface by Oil-Soluble and Water-Soluble Surfactants, *J. Agr. Food Chem.*, Vol. 40, No. 2, 179-183, ISSN: 0021-8561.
- Dickinson, E. & Yamamoto, Y. (1996). Viscoelastic Properties of Heat-Set Whey Protein-Stabilized Emulsion Gels with Added Lecithin, *J. Food Sci.*, Vol. 61, No. 4, 811-816, ISSN: 0022-1147.
- Dickinson, E. (1997). Properties of Emulsions Stabilized with Milk Proteins: Overview of Some Recent Developments, *J. Dairy Sci.*, Vol. 80, No. 10, 2607-2619, ISSN: 0022-0302.
- Dickinson, E. (2003). Hydrocolloids at interfaces and the influence on the properties of dispersed systems, *Food hydrocolloids*, Vol. 17, No. 1, 25-39, ISSN: 0268-005X.
- Diftis, N., & Kiosseoglou, V. (2004). Competitive adsorption between a dry heated soy protein dextran mixture and surface active materials in oil-in-water emulsions. *Food Hydrocolloids*, Vol. 18, No. 6, 639-646, ISSN: 0268-005X.
- Dornbos, D. L.; Mullen, R. E. & Hammond, E. G. (1989). Phospholipids of Environmentally Stressed Soybean Seeds, *JAOCs*, Vol. 66, No. 9, 1371-1373, ISSN: 0003-021X.
- EFSA (2004). Opinion of the scientific panel on food additives, flavourings, processing aids and materials in contact with food (AFC) on a request from the commission related to the use of epoxidised soybean oil in food contact materials. *EFSA Journal*, Vol. 64, 1-17.
- Endres, J. G. (2001). Soy protein products: characteristics, nutritional aspects, and utilization, Revised and expanded edition, AOCS Press, ISBN 1-893997-27-8, Champaign.
- Farook, U.; Stride, E. & Edirisinghe, M. J. (2009). Preparation of suspensions of phospholipid-coated microbubbles by coaxial electrohydrodynamic atomization, *J. R. Soc. Interface*, Vol. 6, No. 32, 271-277, ISSN: 1742-5689.
- Foegeding, E.; Luck, P. & Davis, J. (2006). Factors determining the physical properties of protein foams. *Food Hydrocolloids*, Vol. 20, No. 2-3, 284-292, ISSN: 0268-005X.

- Garti, N. (2002). Food emulsifiers: structure-reactivity relationships, design, and applications, In: *Physical properties of lipids*, Marangoni, A. G. & Narine, S. (Ed.), 265-386, Marcel Dekker, Inc., ISBN: 978-0-8247-0005-8, New York.
- Gierula, M. P.; Takaoka, Y.; Miyagawa, H.; Kitamura, K. & Kusumi, A. (1999). Charge Pairing of Headgroups in Phosphatidylcholine Membranes: A Molecular Dynamics Simulation Study, *Biophys. J.*, Vol. 76, No. 3, 1228-1240, ISSN: 0006-3495.
- Guo, Y.; Hardesty, J. H.; Mannari, V. M. & Massingill, J. L. (2007). Hydrolysis of Epoxidized Soybean Oil in the Presence of Phosphoric Acid, *JAOCs*, Vol. 84, No. 10, 929-935, ISSN: 0003-021X.
- Hamada, J. S. & Marshall, W. E. (1989). Preparation and functional properties of enzymatically deamidated soy proteins, *J. Food Sci.*, Vol. 54, No. 3, 598-601, ISSN: 0022-1147.
- Hamada, J. S. (1992). Effects of heat and proteolysis on deamidation of food proteins using peptidoglutaminase, *J. Agr. Food Chem.*, Vol. 40, No.5, 719-723, ISSN: 0021-8561.
- Hirotsuka, M.; Taniguchi, H.; Narita, H. & Kito, M. (1984). Increase in emulsification activity of soy lecithin-soy protein complex by ethanol and heat treatments. *J. Food Sci.*, Vol. 49, No. 4, 1105-1110, ISSN: 0022-1147.
- Iwabuchi, S. & Yamauchi F. (1987). Determination of glycinin and .beta.-conglycinin in soybean proteins by immunological methods, *J. Agr. Food Chem.*, Vol. 35, No. 2, 200-205, ISSN: 0021-8561.
- Johansson, D. & Bergenståhl, B. (1992). The Influence of Food Emulsifiers on Fat and Sugar Dispersions in Oils. I. Adsorption, Sedimentation, *JAOCs*, Vol. 69, No. 8, 705-717, ISSN: 0003-021X.
- Jambrak, A. R.; Lelas, V.; Mason, T. J.; Krešić, G. & Badanjak, M. (2009). Physical properties of ultrasound treated soy proteins, *J. Food Eng.*, Vol. 93, No. 4, 386-393, ISSN: 0260-8774.
- Joshi, A.; Paratkar, S. G. & Thorat, B. N. (2006). Modification of lecithin by physical, chemical and enzymatic methods, *Eur. J. Lipid Sci. Tech.*, Vol. 108, No. 4, 363- 373, ISSN: 1438-7697.
- Kajiyama, N.; Isobe, S.; Uemura, K. & Noguchi, A. (1995). Changes of soy protein under ultra-high hydraulic pressure, *Int. J. Food Sci. Tech*, Vol. 30, No. 2, 147-158, ISSN: 0950-5423.
- Karsa, D. R. & Houston, J. (2006). Chapter 1: What are surfactants, In: *Chemistry and technology of surfactants*, Farn r. J. (Ed.), 1-23, Blackwell Publishing Ltd., ISBN: 978-14051-2696-0, Oxford.
- Kawakatsu, T.; Kikuchi, Y. & Nakajima, M. (1997). Regular-Sized Cell Creation in Microchannel Emulsification by Visual Microprocessing Method. *JAOCs*, Vol. 74, No. 3, 317-321, ISSN: 0003-021X.
- Kinsella, J. E. (1976). Functional properties of proteins in foods: A survey, *Crit. Rev. Food Sci.*, Vol. 7, No. 3, 219-280, ISSN: 1040-8398.
- Kolar, C. W.; Cho, I. C. & Watrous, W. L. (1979). Vegetable protein application in yogurt, coffee creamers and whip toppings, *JAOCs*, Vol. 56, No. 3, 389-391, ISSN: 0003-021X.
- Koczko, K.; Nikolov, A. D.; Wasan, D. T.; Borwankar, R. P. & Gonsalvest, A. (1996). Layering of sodium caseinate submicelles in thin liquid films - a new stability mechanism for food dispersions, *J. Colloid Interf. Sci.*, Vol. 178, No. 2, 694-702, ISSN: 0021-9797.

- Krawczyk, T. (1996). "Lecithin: consider the possibilities," *Int. News Fats, Oils Rel. Mat. (INFORM)*, Vol. 7, No.11, 1158- 1165.
- Roesch, R. R. & Corredig, M. (2003). Texture and microstructure of emulsions prepared with soy protein concentrate by highpressure homogenization. *Lebensmittel Wissenschaft und Technologie*, Vol. 36, No.1, 113-124, ISSN 0023-6438.
- Lai, H. M. & Lin, T. C. (2006). Bakery products: science and technology, In: *Bakery products: science and technology*, Hui, Y. H. (Ed.), 3-65, Blackwell Publishing, ISBN: 978-0-8138-0187-2, Oxford.
- Lantz, R. A. (1989). Industrial methods of analysis, In: *Lecithins: Sources, Manufacture and Uses*, Szuhaj, B. F. (Ed.), 162-173, AOCS, ISBN: 0-935315-27-6, Champaign.
- Lee, K. W.; Cheng, H.; Jin, Y.; Kim, Y. W. & Chung, K. W. (2008). Modification of soybean oil for intermediates by epoxidation, alcoholysis and amidation, *Korean J. Chem. Eng.*, Vol. 25, No. 3, 474-482, ISSN: 0256-1115.
- Li, R. (2006). Soy product off-flavor generating, masking, and flavor creating, In: *Soy applications in food*, Riaz, M. N. (Ed.), 227-248, Taylor & Francis, ISBN: 978-0-8493-2981-4, Boca Raton.
- List, G. R. (1989). Commercial manufacture of lecithin, In: *Lecithins: Sources, Manufacture and Uses*, Szuhaj, B. F. (Ed.), 145-161, AOCS, ISBN: 0-935315-27-6, Champaign.
- Liu, K. S. (1997). *Soybeans: Chemistry, technology and utilization*, ISBN: 978-0-8342-1299-2, Chapman & Hall, New York.
- Liu, Z. S. & Erhan, S. Z. (2010). Soy-based thermosensitive hydrogels for controlled release systems, United States Patent 7691946.
- Manjula, S. & Subramanian, R. (2008), Laboratory Studies on Membrane Deoiling of Lecithin, *JAACS*, Vol. 85, No. 6, 573-580, ISSN: 0003-021X.
- Marellapudi, S. L. K.; Vemulapalli, V.; Penumarthi, V. & Rachapudi, B. N. P. (2002). Enzymatic process for the preparation of an acetylated phospholipid, United States Patent 6403344.
- McCrae, C. H. (1999). Heat stability of milk emulsions: phospholipid-protein interactions, *J. Dairy Res.*, Vol. 9, No. 3-6, 227- 231, ISSN: 0022-0299.
- McClements, D. J. (2005). *Food emulsions: principles, practices, and techniques*, CRC Press, ISBN: 978-0-8493-2023-1, Boca Raton.
- McEvily, A. J. & Zaks, A. (1991). Emulsifiers and Surfactants, In: *Biotechnology and Food Ingredients*, Goldberg, I. & Williams, R. (Ed.), 193-222, Van Nostrand Reinhold, ISBN: 0442-00272-6, New York.
- McSweeney, S. L. (2008). Emulsifiers in infant nutritional products, In: *Food emulsifiers and their applications*, Hasenhuettl, G. L. & Hartel, R. W. (Ed.), second edition, 233-262, Springer, ISBN: 978-0-387-75283-9, New York.
- Melsen, J. P. & Walstra, P. (1989). Stability of recombined milk fat globules, *Neth. Milk Dairy J.* Vol. 43, No. 1, 63-78, ISSN: 0028-209X.
- Miura, S.; Mutoh, T.; Shiinoki, Y. & Yoshioka, T. (2006). Emulsifying properties of phospholipids in the reconstitution of cream using butter oil, *Eur. J. Lipid Sci. Tech.*, Vol. 108, No. 11, 898-903, ISSN: 1438-7697.
- Molina, E.; Papadopoulou, A. & Ledward, D. A. (2001). Emulsifying properties of high pressure treated soy protein isolate and 7S and 11S globulins, *Food Hydrocolloids*, Vol. 15, No. 3, 263-269, ISSN: 0268-005X.

- Montanari, L.; Fantozzi, P.; Snyder, J. M. & King, J. W. (1999). Selective Extraction of Phospholipids from Soybeans with Supercritical Carbon Dioxide and Ethanol, *J. Supercrit. Fluid*, Vol. 14, No. 2, 87-93, ISSN: 0896-8446.
- Moure, A.; Sineiro, J.; Domínguez, H. & Parajó, J. C. (2006). Functionality of oilseed protein products: A review, *Food Res. Int.*, Vol. 39, No. 9, 945-963, ISSN: 0963-9969.
- Mujoo, R.; Trinh, D. T. & Ng, P. K. W. (2003). Characterization of storage proteins in different soybean varieties and their relationship to tofu yield and texture, *Food Chemistry*, Vol. 82, No. 2, 265-273.
- Murry, R. S. (2007). Stabilization of bubbles and foams, *Curr. Opin. Colloid In.*, Vol. 12, No. 4-5, 232-241, ISSN: 1359-0294.
- Muthusamy, K.; Gopalakrishnan, S.; Ravi, T. K. & Sivachidambaram, P. (2008). Biosurfactants: Properties, commercial production and application, *Curr. Sci.*, Vol. 94, No. 6, 736-747, ISSN: 0011-3891.
- Nakashima, T.; Shimizu, M. & Kukizaki, M. (1991). Membrane Emulsification by Microporous Glass. *Key Eng. Mater.*, Vol. 61-62, 513-516, ISSN: 1013-9826.
- Nasir, M. I.; Bernards, M. A. & Charpentier, P. (2007). Acetylation of Soybean Lecithin and Identification of Components for Solubility in Supercritical Carbon Dioxide, *J. Agr. Food Chem.*, Vol. 55, No. 5, 1961-1969, ISSN: 0021-8561.
- Nieuwenhuyzen, W. V. (1976). Lecithin production and properties, *JAOCS*, Vol. 53, No. 4, 425-427, ISSN: 0003-021X.
- Nieuwenhuyzen, W. V. (1981). The Industrial Uses of Special: A Review, *JAOCS*, Vol. 58, No. 10, 886-888, ISSN: 0003-021X.
- Nieuwenhuyzen, W. V. & Szuhaj, B. F. (1998). Effects of lecithins and proteins on the stability of emulsions. *Fett/Lipid.*, Vol. 100, No. 7, 282-291, ISSN: 1521-4133.
- Nieuwenhuyzen, W. V. & Tomas, M. C. (2008). Update on vegetable lecithin and phospholipid technologies, *Eur. J. Lipid Sci. Tech.*, Vol. 110, No. 5, 472-486, ISSN: 1438-7697.
- Nieuwenhuyzen, W. V. (2010). Lecithin and other phospholipids, In: *Surfactants from renewable resources*, Wiley Series in Renewable Resources, Kjellin, M., Johansson, I. (Ed.), 191-212, Wiley, ISBN: 978-0-470-76041-3, West Sussex.
- Ogawa, S.; Decker, E. A. & McClements, D. J. (2003). Influence of Environmental Conditions on the Stability of Oil in Water Emulsions Containing Droplets Stabilized by Lecithin-Chitosan Membranes, *J. Agr. Food Chem.*, Vol. 51, No. 18, 5522-5527, ISSN: 0021-8561.
- Ogden, L. G. & Rosenthal, A. J. (1997). Interactions between tristearin crystals and proteins at the oil-water interface. *J. Colloid Interf. Sci.*, Vol. 191, No. 1, 38-47, ISSN: 0021-9797.
- Oleszek, W. & Hamed, A. (2010). Saponin-based surfactants, In *Surfactants from renewable resources*, Wiley Series in Renewable Resources, Kjellin, M. & Johansson, I. (Ed.), 239-252, Wiley, ISBN: 978-0-470-76041-3, West Sussex.
- Onari, H. (2005). Microbubbles and its application to the fisheries technology. In: *Concepts in Basic Bubble and Foam Engineering*, Ishii, T.; Tamura, T.; Tsukada, T. & Tsujii, K. (Ed.), 475-484, Techno System, ISBN: 978-4924728479, Tokyo.
- Ortiz, S. E. M. & Wagner, J. R. (2002). Hydrolysates of native and modified soy protein isolates: structural characteristics, solubility and foaming properties, *Food Res. Int.*, Vol. 35, No. 6, 511-518, ISSN: 0963-9969.

- Park, S. K.; Hettiarachchy, N. S.; Ju, Z. Y. & Gennadios, A. (2002). Formation and properties of soy protein films and coatings, In: *Protein-based films and coatings*, Gennadios, A. (Ed.), pp123-138, CRC Press, ISBN: 978-1587-16107-0, Boca Raton.
- Patel, M. (2003). Surfactants based on renewable raw materials: carbon dioxide reduction potential and policies and measures for the European Union, *J. Ind. Ecol.* Vol. 7, No. 3-4, 47-62, ISSN: 1088-1980.
- Pedersen, K. B. (2001). Interesterification of phospholipids. United States Patent 6284501.
- Palazzo, G.; Angelico, R.; Ceglie, A. & Olsson, U. (2003). Lecithin organogels: structure, dynamics and phase behavior, In: *Self-assembly*, Robinson, B. H. (Ed.), 318-328, IOS Press, ISBN: 1-58603-382-4, Burke.
- Puppo, M.C.; Speroni, F.; Chapleau, N.; Lamballerie, M.; Añón, M. C. & Anton, M. (2005). Effect of high-pressure treatment on emulsifying properties of soybean proteins, *Food Hydrocolloids*, Vol. 19, No. 2, 289-296, ISSN: 0268-005X.
- Roudsari, M.; Nakamura, A.; Smith, A. & Corredig, M. (2006). Stabilizing Behavior of Soy Soluble Polysaccharide or High Methoxyl Pectin in Soy Protein Isolate Emulsions at Low pH, *J. Agr. Food Chem.*, Vol. 54, No. 4, 1434-1441, ISSN: 0021-8561.
- Rousseau, D. (2000). Fat crystals and emulsion stability: a review, *Food Res. Int.*, Vol. 33. No. 1, 3-14, ISSN: 0963-9969.
- Rust D. & Wildes, S. (2008). Surfactants: a market opportunity study update, United soybean board, Omni Tech International, Ltd., Midland.
- Rydhag, L. & Wilton, I. (1981). The function of phospholipids of soybean lecithin in emulsions, *JAOCS*, Vol. 58, No. 8, 830-837, ISSN: 0003-021X.
- Schneider, M. (1989). Fractionation and Purification of Phospholipids, In: *Lecithins: Sources, Manufacture, and Uses*, Szuhaj, B. F. (Ed.), 109-130, American Oil Chemists' Society, ISBN: 0-935315-27-6, Champaign.
- Scuriatti, M. P.; Tomás, M. C. & Wagner, J. R. (2003). Influence of Soybean Protein Isolates-Phosphatidylcholine Interaction on the Stability of Oil-in-Water Emulsions, *JAOCS*, Vol. 80, No. 11, 1093-1100, ISSN: 0003-021X.
- Stefan, A.; Palazzo, G.; Ceglie, A.; Panzavolta, E. & Hochkoeppler, A. (2003). Water-in-oil macroemulsions sustain long-term viability of microbial cells in organic solvents, *Biotechnol Bioeng.*, Vol. 81, No. 3, 323-328, ISSN: 0006-3592.
- Surh, J.; Jeong, Y. G. & Vladisavljević, G. T. (2008). On the preparation of lecithin-stabilized oil-in-water emulsions by multi-stage premix membrane emulsification, *J. Food Eng.*, Vol. 89, No. 2, 164-170, ISSN: 0260-8774.
- Takahashi, S. (2005). Engineering applications of microbubbles. In: *Concepts in Basic Bubble and Foam Engineering*, Ishii, T.; Tamura, T.; Tsukada, T. & Tsujii, K. (Ed.), 463-474, Techno System, ISBN: 978-4924728479, Tokyo.
- Teberikler, L.; Koseoglu, S. & Akgerman, A. (2001). Selective Extraction of Phosphatidylcholine from Lecithin by Supercritical Carbon Dioxide/Ethanol Mixture, *JAOCS*, Vol. 78, No. 2, 115-120, ISSN: 0003-021X.
- Taylor, T. M.; Davidson, P. M.; Bruce, B. D. & Weiss, J. (2005). Liposomal Nanocapsules in Food Science and Agriculture, *Crit. Rev. Food Sci.*, Vol. 45, No. 7-8, 587-605, ISSN: 1040-8398.
- Tong, J.; Nakajima, M. & Nabetani, H. (2002). Preparation of phospholipid oil-in-water microspheres by microchannel emulsification technique, *Eur. J. Lipid Sci. Tech.* Vol. 104, No. 4, 216-221, ISSN: 1438-7697.

- Tsutsui, J. M.; Xie, F. & Porter, R. T. (2004). The use of microbubbles to target drug delivery, *Cardiovasc. Ultrasound*, 2:23, ISSN: 1476-7120.
- Vani, B. & Zayas, J. F. (1995). Foaming properties of selected plant and animal proteins. *J. Food Sci.*, Vol. 60, No. 5, 1025-1028, ISSN: 0022-1147.
- Vikbjerg, A. F.; Rusig, J. Y.; Jonsson, G.; Mu, H. & Xu, X. (2006). Comparative Evaluation of the Emulsifying Properties of Phosphatidylcholine after Enzymatic Acyl Modification, *J. Agr. Food Chem.*, Vol. 54, No. 9, 3310-3316, ISSN: 0021-8561.
- Vladisavljević, G. T.; Shimizu, M. & Nakashima, T. (2005). Permeability of hydrophilic and hydrophobic Shirasus-porous glass (SPG) membranes to pure liquids and its microstructure, *J. Membrane Sci.*, Vol. 250, No. 1-2, 69-77, ISSN: 0376-7388.
- Wang, G. & Wang, T. (2008). Oxidative stability of egg and soy lecithin as affected by transition metal ions and pH in emulsion, *J. Agric. Food Chem.*, Vol. 56, No. 23, 11424-11431, ISSN: 0021-8561.
- Wheatley, M.; Forsberg, F.; Dube, N.; Patel, M. & Oeffinger B. (2006). Surfactant-stabilized contrast agent on the nanoscale for diagnostic ultrasound imaging, *Ultrasound Med. Biol.*, Vol. 32, No. 1, 83-93, ISSN: 0301-5629.
- Weyland, M. & Hartel, R. (2008). Emulsifiers In: Confectionery, in *Food emulsifiers and their applications*, Hasenhuettl, G. L. & Hartel, R. W. (Ed.), second edition, 285-306, Springer, ISBN: 978-0-387-75283-9, New York.
- WHO. (1974). Toxicological evaluation of some food additives including anticaking agents, antimicrobials, antioxidants, emulsifiers and thickening agents, in WHO Food Additives Series (FAS), NO. 5, Geneva.
- Wong, H. L.; Rauth, A. M.; Bendayan, R.; Manias, J. L.; Ramaswamy, M.; Liu, Z.; Erhan, S. Z. & Wu, X. Y. (2006). A new polymer-lipid hybrid nanoparticle system increases cytotoxicity of doxorubicin against multidrug-resistant human breast cancer cells. *Pharm. Res-Dordr.*, Vol. 23, No. 7, 1574-1585, ISSN: 0724-8741.
- Wu, Y. & Wang, T. (2003). Soybean Lecithin Fractionation and Functionality, *JAOCS*, Vol. 80, No. 4, 319-326, ISSN: 0003-021X.
- Wu, Y. & Wang, T. (2004). Fractionation of Crude Soybean Lecithin with Aqueous Ethanol, *JAOCS*, Vol. 81, No. 7, 697-704, ISSN: 0003-021X.
- Xu, J.; Liu, Z. & Erhan, S. Z. (2008a). Viscoelastic Properties of a Biological Hydrogel Produced from Soybean Oil, *JAOCS*, Vol. 85, No. 3, 285-290, ISSN: 0003-021X.
- Xu, Q. Y.; Nakajima, M.; Ichikawa, S.; Nakamura, N. & Shiina, T. (2008b). A comparative study of microbubble generation by mechanical agitation and sonication, *Innov. Food Sci. Emerg.*, Vol. 9, No. 4, 489-494, ISSN: 1466-8564.
- Xu, Q. Y.; Nakajima, M.; Ichikawa, S.; Nakamura, N.; Roy, P.; Okadome H. & Shiina, T. (2009). Effects of surfactant and electrolyte concentrations on bubble formation and stabilization, *J. Colloid Interf. Sci.*, Vol. 332, No. 1, 208-214, ISSN: 0021-9797.
- Xu, Q. Y.; Liu, Z. S.; Nakajima, M.; Ichikawa, S.; Nakamura, N.; Roy, P.; Okadome H. & Shiina, T. (2010). Characterization of a soybean oil-based biosurfactant and evaluation of its ability to form microbubbles, *Bioresource Technol.*, Vol. 101, No.10, 3711-3717, ISSN: 0960-8524.

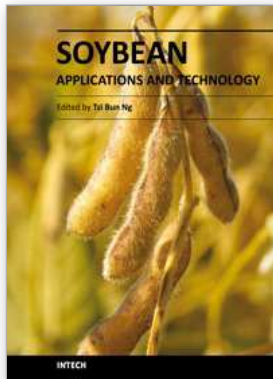

Soybean - Applications and Technology

Edited by Prof. Tzi-Bun Ng

ISBN 978-953-307-207-4

Hard cover, 402 pages

Publisher InTech

Published online 26, April, 2011

Published in print edition April, 2011

Soybean is an agricultural crop of tremendous economic importance. Soybean and food items derived from it form dietary components of numerous people, especially those living in the Orient. The health benefits of soybean have attracted the attention of nutritionists as well as common people.

How to reference

In order to correctly reference this scholarly work, feel free to copy and paste the following:

Qingyi Xu, Mitsutoshi Nakajima, Zengshe Liu and Takeo Shiina (2011). Soybean-based Surfactants and Their Applications, Soybean - Applications and Technology, Prof. Tzi-Bun Ng (Ed.), ISBN: 978-953-307-207-4, InTech, Available from: <http://www.intechopen.com/books/soybean-applications-and-technology/soybean-based-surfactants-and-their-applications>

INTECH

open science | open minds

InTech Europe

University Campus STeP Ri
Slavka Krautzeka 83/A
51000 Rijeka, Croatia
Phone: +385 (51) 770 447
Fax: +385 (51) 686 166
www.intechopen.com

InTech China

Unit 405, Office Block, Hotel Equatorial Shanghai
No.65, Yan An Road (West), Shanghai, 200040, China
中国上海市延安西路65号上海国际贵都大饭店办公楼405单元
Phone: +86-21-62489820
Fax: +86-21-62489821

© 2011 The Author(s). Licensee IntechOpen. This chapter is distributed under the terms of the [Creative Commons Attribution-NonCommercial-ShareAlike-3.0 License](#), which permits use, distribution and reproduction for non-commercial purposes, provided the original is properly cited and derivative works building on this content are distributed under the same license.

Polymerization of Soybean Oil with Superacids

Ionescu Mihail and Petrović S. Zoran

*Pittsburg State University, Kansas Polymer Research Center, Pittsburg, KS, 66762
USA*

1. Introduction

Soybean oil is a triester of glycerol (triglyceride) with saturated and unsaturated fatty acids, 80-85% being unsaturated fatty acids (Fig.1). The iodine value of soybean oil, a direct measure of double bond content, is in the range of 125-132 gI₂/100g. Soybean oil has around 4.6 double bonds and all the double bonds are in the "cis" configuration. The saturated fatty acids are palmitic (C16:0) and stearic (C18:0) and the unsaturated fatty acids are oleic (C18:1), linoleic (C18:2) and linolenic (C18:3). The average molecular weight of soybean oil is M=874 (Ionescu, 2005). From the point of view of macromolecular chemistry, soybean oil having 4.6 double bonds/mol is a polyfunctional monomer (SCHEME I).

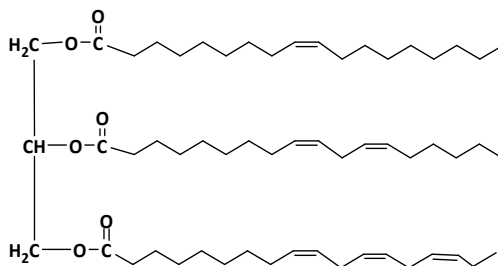

Scheme I. Structure of soybean oil

The fatty acid composition of soybean oil is presented in Table 1.

Unfortunately, the internal 1,2 disubstituted nonconjugated double bonds are of low reactivity and polymerize with difficulty (Petrović, 2008). There are two methods for polymerization of soybean oil on a larger scale, both methods being radical initiated processes: thermal polymerization and air blown polymerization. Thermal polymerization (called heat bodied polymerization) is carried out by simple heating of soybean oil at very high temperatures of 290-330 °C with or without catalysts such as antraquinone (Erhan, 1994, 1998, Wang, 1999, Powers, 1950, Whereleer 1969). Viscous liquid polymers of soybean oil are formed with the yield of 75-80% and a loss of 20-25% of volatile organic compounds resulting from thermal degradation (Bernstein, 1946). The second process also used in industry for "air blown oils" (Christianson 2007, Geiger, 2006) consists of bubbling air through soybean oil at temperatures of 100-110 °C for a relatively long time (30-50 hours), resulting in viscous liquid polymers. Unfortunately, in this process many undesired organic groups are formed as a result of oxidation of fatty acid chains with air oxygen such as:

| No. | Fatty acid | Percentage in soybean oil, % | Number of C atoms: Number of double bonds | Structure of fatty acid |
|-----|----------------|------------------------------|--|--|
| 1 | Palmitic acid | 10-11 | C16:0 |  |
| 2 | Stearic acid | 4-6 | C18:0 |  |
| 3 | Oleic acid | 23-25 | C18:1 |  |
| 4 | Linoleic acid | 50-55 | C18:2 |  |
| 5 | Linolenic acid | 6-9 | C18:3 |  |

Table 1. Fatty acid composition of soybean oil

hydroxyl, carboxyl, aldehydes, ketones, hydroperoxides. Because of the 1,2 substitution with electron releasing substituents (the alkyl fragments of fatty acid chains) the internal double bonds of soybean oil are rich in electrons and as a consequence are susceptible to the attack of electron deficient species such as organic radicals and cations. Cationic polymerization of soybean oil is an old process. Cationic polymerization of natural oils is described in two old patents. One describes polymerization of soybean oil at 130 °C, in the presence of 2.8% of BF₃ as a catalyst (Uloth, 1944). Liquid polymers of soybean oil with viscosity 5 times higher than those of initial soybean oil are obtained. The second patent (Eichvald, 1939) describes the polymerization of soybean oil at 70 °C in the presence of 2% BF₃ as a catalyst during 50-80 hours. Cationic homopolymerization of soybean oil and cationic copolymerization of soybean and other natural oils (fish oil, tung oil etc.) with vinyl monomers, such as styrene, divinyl benzene, norbornene, dicyclopentadiene, were carried out by Larock at Iowa State University (USA) (Li & Larock, 2000, 2001a,b, Li et al 2000 a,b, 2001, Larock & Li, 2000, Larock & Hanson 2001). They used the following conditions: 4-7% of BF₃*Et₂O as a catalyst and 110 °C to obtain solid polymers with some interesting properties. The cationic polymerization of soybean oil initiated by 2% BF₃*Et₂O at 110-140 °C in supercritical carbon dioxide was developed successfully at the institute NCAUR from Peoria (USA), by the group of Sevim Erhan (Liu, 2007).

As a general observation, in the mentioned patents and papers the catalyst used for cationic polymerization of soybean oil was without exception boron trifluoride or its complex with diethylether. Cationic polymerization of fatty acids or of fatty acid methyl esters, by using the same BF₃ as a catalyst, was described in the literature (Turner, 1990, Croston, 1952, Ghodssi, 1970). The cationic oligomerization of fatty acids to dimeric and trimeric acids catalyzed by acidic clays at higher temperatures (230-240 °C) is described in several patents (Hayes 1986, Conroy 1972, Milks 1969, Vreswijk 1990, Wheeler 1969, Hayes 1986, Difranco, 2000). The present chapter describes a new process for cationic polymerization of soybean oil catalyzed by superacids (HBF₄, CF₃SO₃H, HSbF₆ etc.), in mild reaction conditions

(temperature around 80-100 °C, atmospheric pressure, at 1% catalyst concentration, during several hours) and in practically quantitative yield (Ionescu & Petrović 2009). In 4-6 hours of cationic polymerization liquid polymers, of viscosity 100-260 times higher than those of initial soybean oil are formed. Reaction times longer than 6 hours result in solid polymers. We studied the effect of various parameters on the cationic polymerization of soybean oil with superacids, we propose a new reaction mechanism for this kind of unconventional cationic polymerization reaction of soybean oil and we characterized the resulted polymers. Our main objective was to obtain liquid viscous polymers, in high yield, by cationic polymerization of soybean oil with superacids, as an economical alternative to the high energy consumption and modest yield of heat bodied oils.

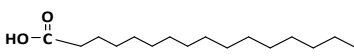
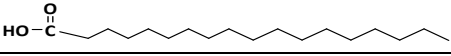
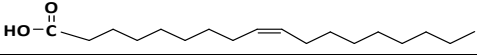
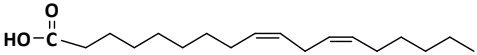
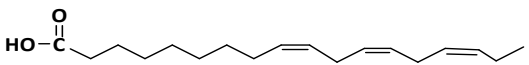
2. General procedure for cationic polymerization of soybean oil with superacids

A 1L glass reactor is charged with 500-600g of standard RBD soybean oil (Refined, Bleached, Deodorized) and about 9.5g of 54% solution of HBF_4 in diethyl ether (1% of pure HBF_4). The oil/catalyst mixture is stirred at room temperature for 20-30 minutes under protective atmosphere of nitrogen. In this interval of time the color of the reaction mass changed from the initial yellow color of soybean oil to dark brown, due to the formation of cationic active centers-conjugated allyl cations. The temperature is increased to 90 °C and is maintained at 88-92 °C for about six hours. In the first 3-4 hours the viscosity of the reaction mass increases slowly, but after 4 hours a marked increase of viscosity occurs. After about 6 hours of cationic polymerization viscosity rises to 8-16 Pa.s at 25 °C, which is 100-260 times higher than those of soybean oil (viscosity of soybean oil is around 0.06 Pa.s at 25 °C). After 6 hours the reaction is stopped and the polymerized oil containing the superacid catalyst is purified. The purification consists of the removal of catalyst and of some volatile compounds by treating the product with 3% (w% against the oil) of powdered calcium hydroxide for 1 hour at 50-60 °C. The dark brown color of polymerized oil changes to yellow after about 10-15 minutes of contact with solid $\text{Ca}(\text{OH})_2$. The color change is probably explained by the decomposition of cationic active centers as a consequence of the neutralization of the superacid catalyst. The reaction mass in the form of yellow suspension is filtered under pressure (about 70 p.s.i.) at 60-70 °C. The filtered oil is a transparent viscous liquid of orange color. The volatile compounds, especially diethyl ether from the catalyst and water resulted from catalyst neutralization, are eliminated in a rotary evaporator, under vacuum of 1-5 mmHg and 110-120 °C, for 60 minutes. The final product is a viscous orange liquid with viscosity of 8-16 Pa.s at 25 °C, a high content of oligomers and an acid number of 1.5-3 mg KOH/g. The number average molecular weight is in the range $M_n=1800-2100$, the weight average molecular weight in the range 20,000-50,000 and the molecular weight distribution index M_w/M_n is about 11-15 indicating a broad molecular weight distribution. If the filtration is difficult, especially with very viscous products, around 25% toluene is added before filtration. The solvent is removed together with diethyl ether and water in vacuum distillation step. If the polymerization reaction is continued for more than 6 hours, solid polymers dispersed in liquid polymers are formed. Eventually the entire reaction mass becomes a solid polymer. Our objective was to synthesize liquid viscous polymers as alternative to heat bodied oils by cationic polymerization of soybean oil.

3. General description of cationic polymerization of soybean oil with superacids

A superacid is any acid stronger than 100% sulfuric acid (Hall & Conant, 1927). The superacids are 10^{12} - 10^{16} times stronger than sulfuric acid 100%. (Olah, 2009) The most common superacids are triflic acid ($\text{CF}_3\text{SO}_3\text{H}$), tetrafluoroboric acid (HBF_4), hexafluoroantimonic acid (HSbF_6), hexafluorophosphoric acid (HPF_6), fluoro-sulfonic acid (FSO_3H), perchloric acid (HClO_4) and complexes of Lewis acids with a superacid acids such as $\text{SbF}_5\text{-FSO}_3\text{H}$ (Magic acid) or $\text{SbF}_5\text{-CF}_3\text{SO}_3\text{H}$. Generally the strength of an acid is characterized by pKa [Olah, 1968, 1985, 2009] of the acid or by Hammett constant of acidity H_o (Hammett, 1932). Thus if the pKa of sulfuric acid 100% is $pK_a = -3$, a superacid such as triflic acid has $pK_a = -14$, FSO_3H has $pK_a = -15$ and HClO_4 has $pK_a = -10$. The Hammett constant of acidity of sulfuric acid 100% is $H_o = -12$, the superacids such as triflic acid has $H_o = -14.5$, tetrafluoroboric has $H_o = -15.5$, hexafluoroantimonic $H_o = -28$ and "Magic acid" ($\text{SbF}_5\text{-FSO}_3\text{H}$) has $H_o = -25$ (Olah, 1985, 2009). The superacids which have a true catalytic activity for cationic polymerization of soybean oil are: tetrafluoroboric acid (HBF_4 as solution in diethylether), triflic acid ($\text{CF}_3\text{SO}_3\text{H}$) and hexafluoroantimonic (HSbF_6). Sulfuric acid and all the acids with acidity comparable or lower than those of sulfuric acid 100% such as methanesulfonic acid, nitric acid, phosphoric acid and all the organic acids-do not have any catalytic activity for soybean oil polymerization. As a general rule, only the superacids in pure form or as a solution in organic nonprotic solvents are catalytically active for soybean oil polymerization. Many superacids are delivered in the form of aqueous solutions. All the water solutions of superacids are catalytically inactive for cationic polymerization of soybean oil. The reason is very simple, water destroys the carbocations, the active species involved in any cationic polymerization. One of the best catalysts for soybean oil polymerization is tetrafluoroboric acid available as 54% solution in diethylether. Tetrafluoroboric acid is one of the cheapest superacids available commercially, and was used in the present study. Figures 1 and 2 show the gel permeation chromatograms (GPC) of the reaction mass during polymerization of soybean oil catalyzed by tetrafluoroboric acid (1 wt% against the oil) at 90 °C. Four GPC columns were specially adapted for the analysis of low molecular weights. The observed marked increase in oligomer and polymer content of soybean oil is direct evidence that cationic polymerization of soybean oil takes place. Around 28-30% of initial soybean oil remains unreacted, probably due to the triglycerides containing fatty acids without double bonds (palmitic and stearic acids) and with only one weakly polymerizable double bond (oleic acid).

Figure 3 presents the formation of oligomers during cationic polymerization of soybean oil. The increase of high molecular weight species with time is evident. After around 300 minutes of polymerization, the oligomer content is in the range of 68-72%. The monomer (the initial soybean oil) content decreases continuously and after 250-270 minutes of polymerization goes to a constant value of around 28-30% in polymerized oil.

The increase of viscosity during the cationic polymerization of soybean oil is small in the first 3-4 hours of reaction but very strong after 4-6 hours. Figure 4 shows the viscosity increase during the polymerization of soybean oil with tetrafluoroboric acid (1% concentration against soybean oil calculated as pure HBF_4), at 90 °C.

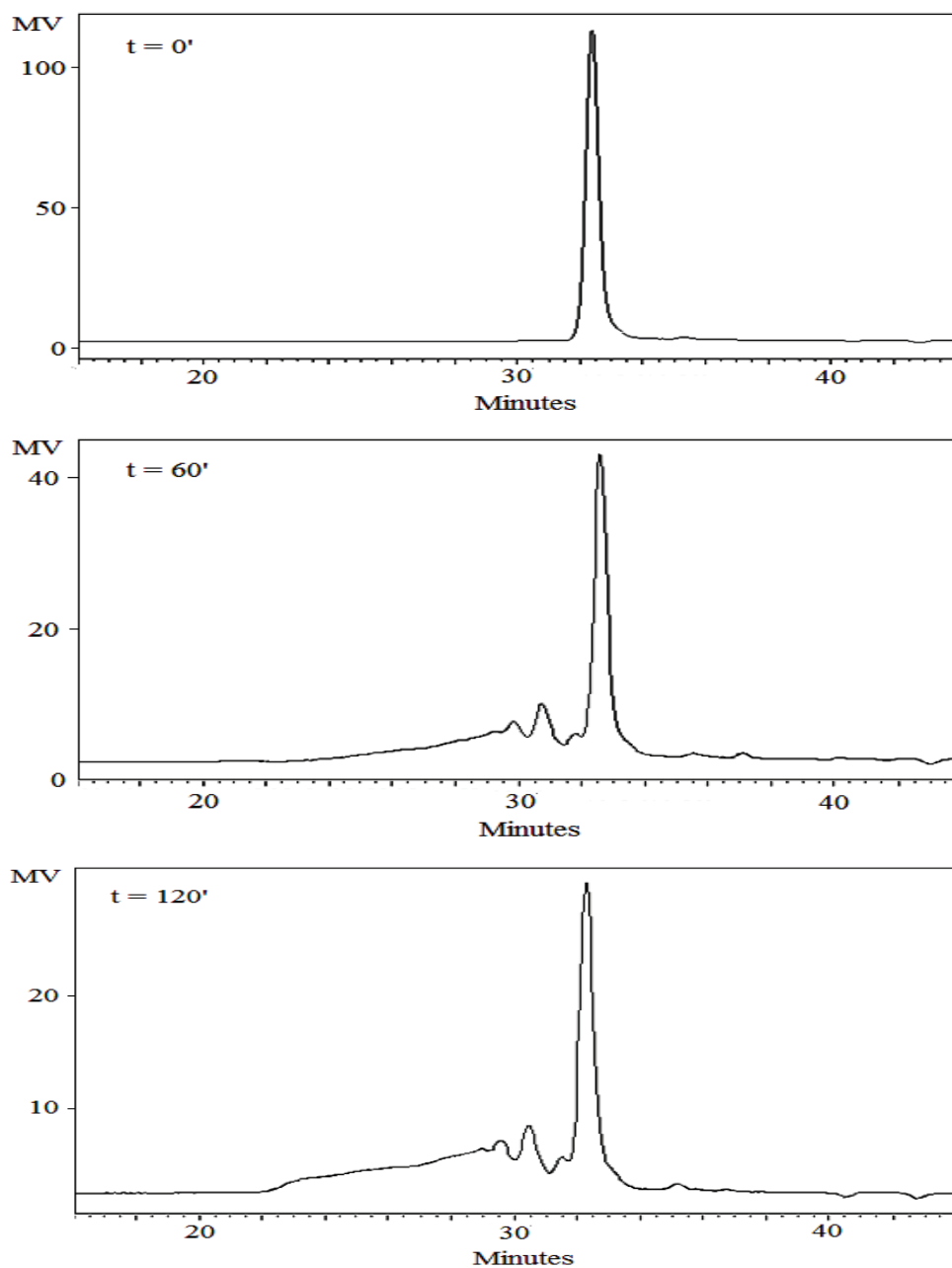

Fig. 1. GPC of initial soybean oil ($t=0$) and of the reaction mass after 60 minutes and 120 minutes of cationic polymerization. Temperature: 90 °C; tetrafluoroboric acid concentration: 1%.

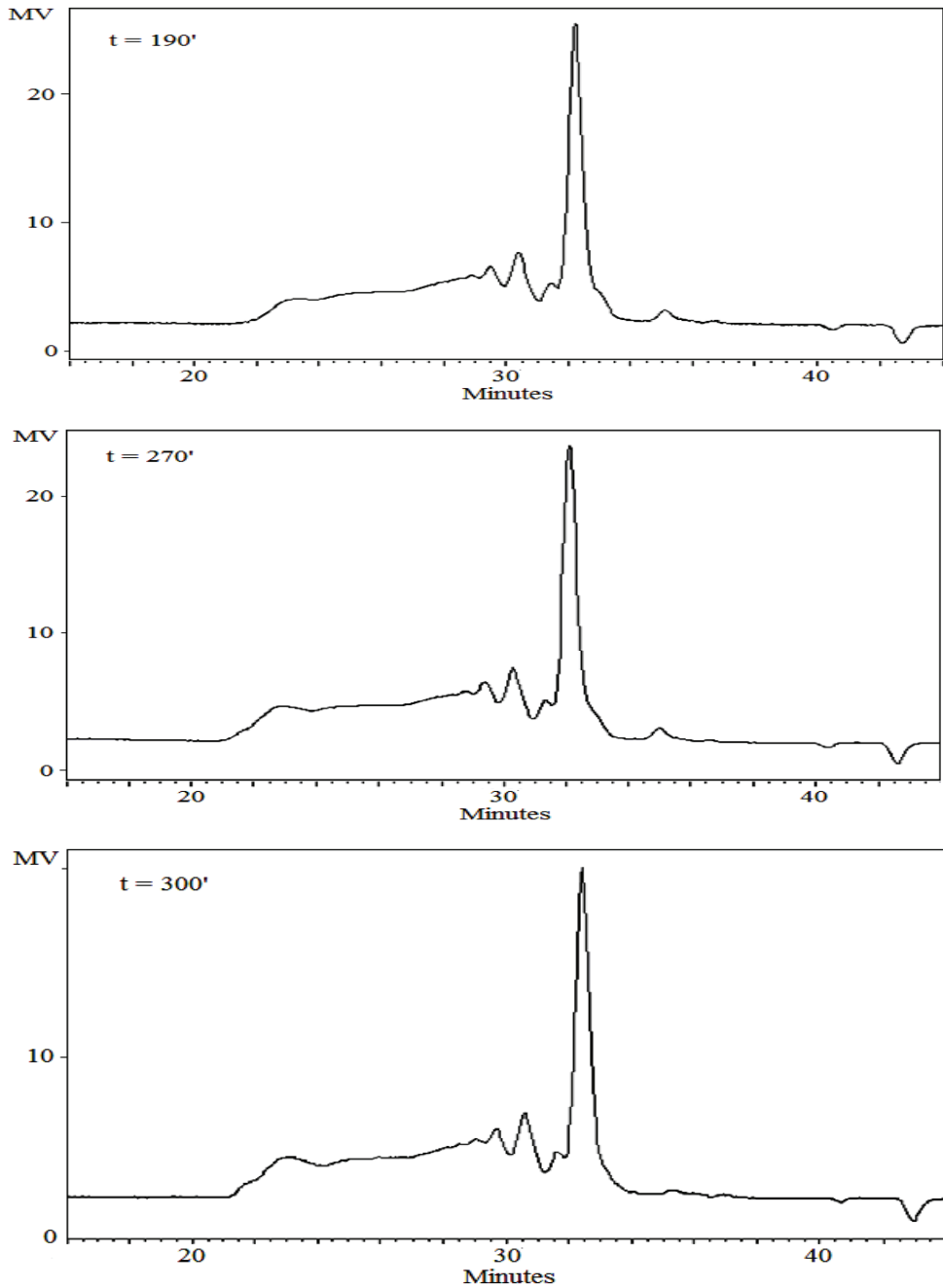

Fig. 2. GPC of the reaction mass after 190, 270 and 300 minutes of cationic polymerization of soybean oil. Temperature: 90 °C; tetrafluoroboric acid concentration: 1%.

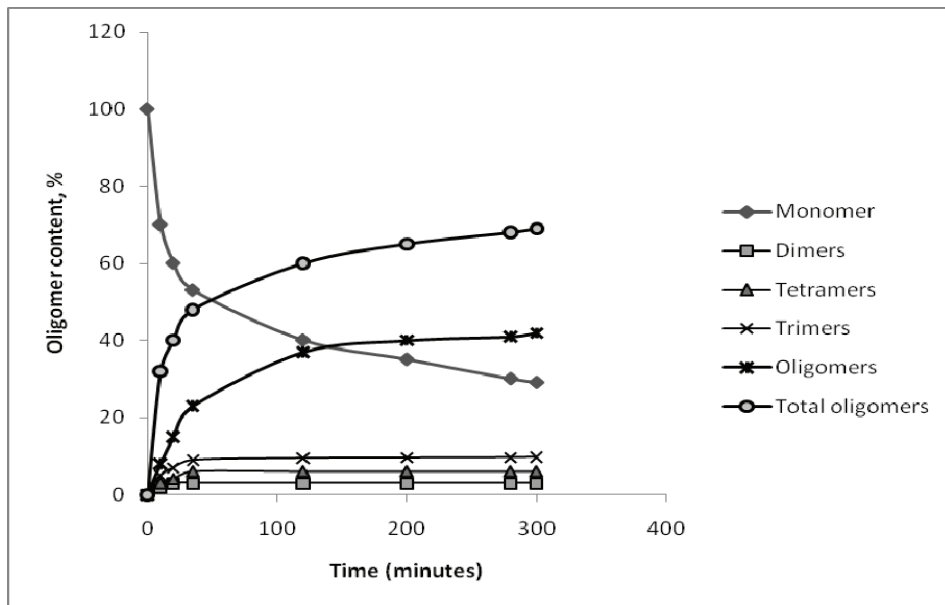

Fig. 3. The effect of time on monomer, dimers, trimers and oligomer content during cationic polymerization of soybean oil

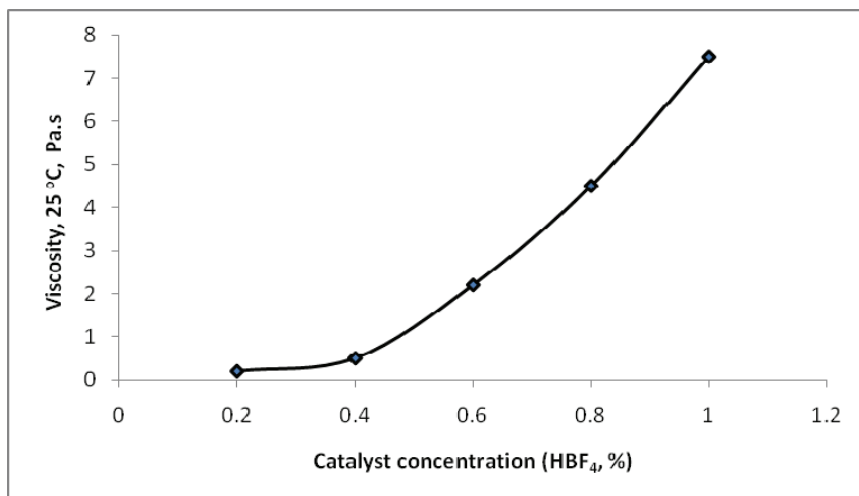

Fig. 4. Effect of time on viscosity during cationic polymerization of soybean oil with tetrafluoroboric acid (1%) at 90 °C.

The increase of viscosity with time is a direct measure of the efficiency of the process used for cationic polymerization of soybean. Figure 5 displays the effect of catalyst nature on viscosity of the reaction mass during cationic polymerization of soybean oil at the same catalyst concentration.

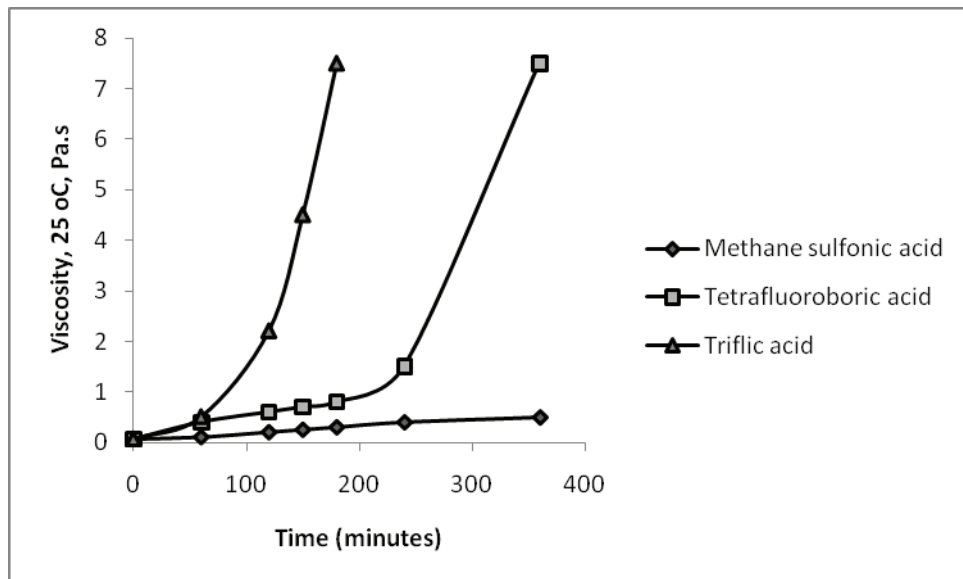

Fig. 5. Effect of catalyst nature on viscosity during cationic polymerization of soybean oil.

Three different catalysts were compared: two superacids (tetrafluoroboric acid and triflic acid) and methanesulfonic acid, with an acidity comparable with those of sulfuric acid. It is clearly observed that triflic acid is more efficient than tetrafluoroboric acid and methanesulfonic acid does not have any notable catalytic activity. The relative efficiency of these catalysts in cationic polymerization of soybean oil is presented below:

Triflic acid > Tetrafluoroboric acid >> methanesulfonic acid

Of course, the catalyst concentration has a strong effect on the viscosity increase during cationic polymerization of soybean oil. Figure 6 shows the effect of tetrafluoroboric acid concentration on viscosity after 5 hours of reaction. Temperature of polymerization has a strong effect on the reactivity of soybean oil in cationic polymerization. At temperatures below 70 °C the polymerization rate is very low. At 70-80 °C a small increase of viscosity is observed. After 6 hours of polymerization viscosity reached 2-5 Pa.s at 25 °C. Temperature of 90 °C leads to a strong increase of viscosity, reaching 14-16 Pa.s after 6 hours of polymerization, in a very controllable manner. Temperatures of 100-110 °C lead to a very rapid increase of viscosity, which is difficult to control, producing solid polymers suspended in a liquid. As mentioned before, our objective is to obtain high viscosity liquid polymers, as an alternative to heat bodied oils. This is the reason for selecting 90 °C as optimal temperature, which leads to high viscosity in a reasonable reaction time without formation of solids. Figure 7 presents the effect of temperature on viscosity of the reaction mass during cationic polymerization of soybean oil. As an interesting experimental observation, the oils containing linolenic acid polymerize more rapidly to high molecular weight polymers. Thus linseed oil having 53-55% linolenic acid leads easily to much higher viscosities of polymerized oil (in fact to much higher molecular weights) as compared with soybean oil, under the same reaction

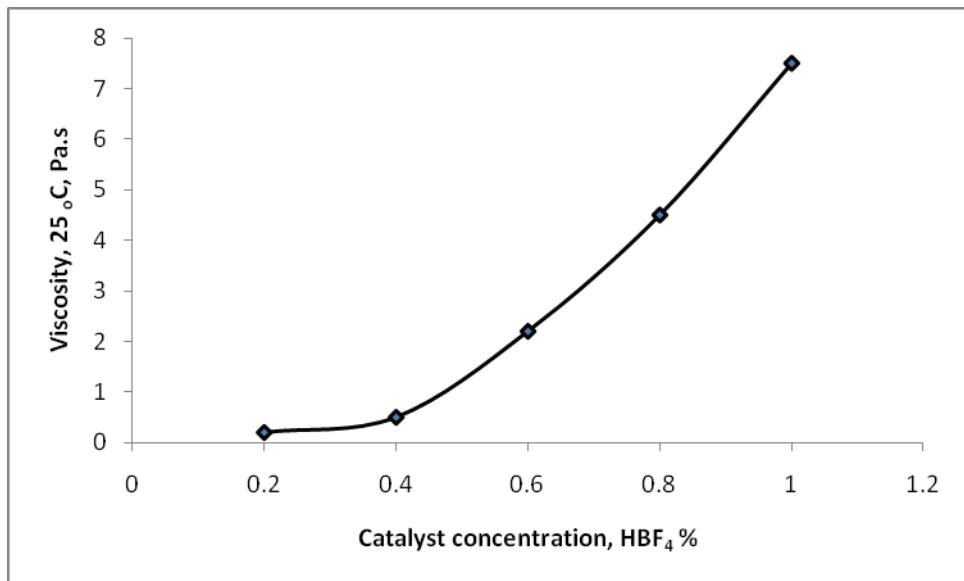

Fig. 6. Effect of catalyst concentration on viscosity of the reaction mass after 5 hours of polymerization of soybean oil at 90 °C.

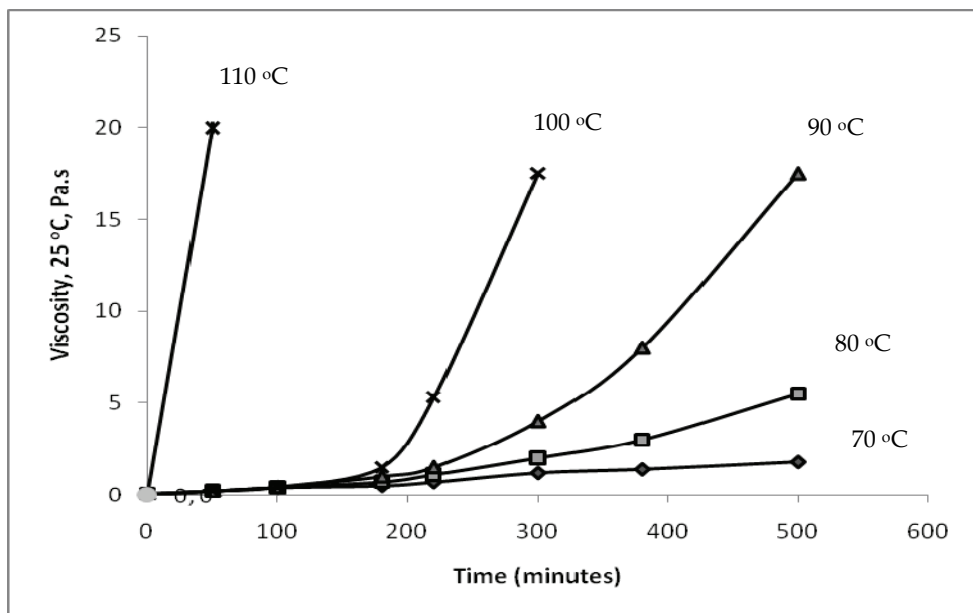

Fig. 7. Effect of temperature on viscosity of the reaction mass during of cationic polymerization of soybean oil. Catalyst HBF₄ 1%.

conditions (the same reaction time, temperature and catalyst concentration). Contrary, the vegetable oils with high content of linoleic acid but with very small content of linolenic acid (corn oil, safflower oil, sunflower oil), polymerize cationically, but in a lesser extent than soybean oil, to much lower viscosity polymers. Copolymers between these oils with low content of linseed oil (20%) polymerize cationically very efficiently proving the important role of linolenic acid to obtain highly viscous polymers. The oils having conjugated double bonds (tung oil, calendula oil, dehydrated castor oil etc.) are extremely reactive in conditions of cationic polymerization of soybean oil with superacids mentioned before. In less than 5 minutes, in a violent polymerization reaction, solid polymers are obtained from tung oil in the form of very dark-brown solid powders.

The increase of the viscosity of soybean oil in the presence of superacids is a consequence of cationic polymerization involving double bonds which are consumed during the reaction. Figure 8 illustrates the decrease of iodine value (IV), which is a direct measure of the double bond content, with time, during the cationic polymerization of soybean oil. At the beginning, a sharp decrease of IV is observed followed by a very slow decay in the last hours of polymerization. The final iodine value of polymerized soybean oil after 5-6 hours of polymerization is relatively high, being around 95-110 $\text{gI}_2/100\text{g}$. This relatively high value is very important for applications in printing inks, paints, varnishes, since double bonds are available for further crosslinking reactions.

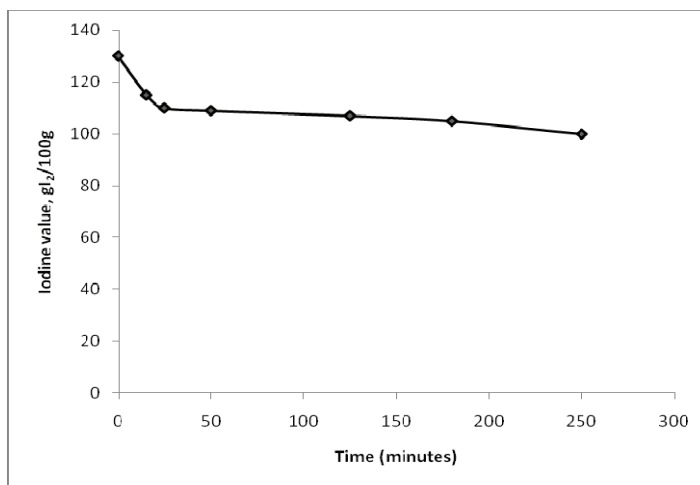

Fig. 8. Variation of iodine value with time in cationic polymerization of soybean oil catalyzed by HBF_4 (1%) at 90°C .

Figures 9 and 10 show the FT-IR spectra of initial soybean oil and polymerized soybean oil after 6 hours of reaction, respectively. Both spectra show the bands characteristics of the carbonyl of ester bonds (at 1746 cm^{-1}), of double bonds at $3008\text{--}3009\text{ cm}^{-1}$, of various C-H from CH_2 groups, CH groups and CH_3 groups (2925 cm^{-1} , 2854 cm^{-1} , $1163\text{--}1463\text{ cm}^{-1}$). It is interesting that the polymerized soybean oil displays the absorption characteristic of "trans" double bonds at 967 cm^{-1} , proving that the rearrangement of some initial "cis" double bonds of soybean oil to "trans" double bonds occurs in the presence of superacids.

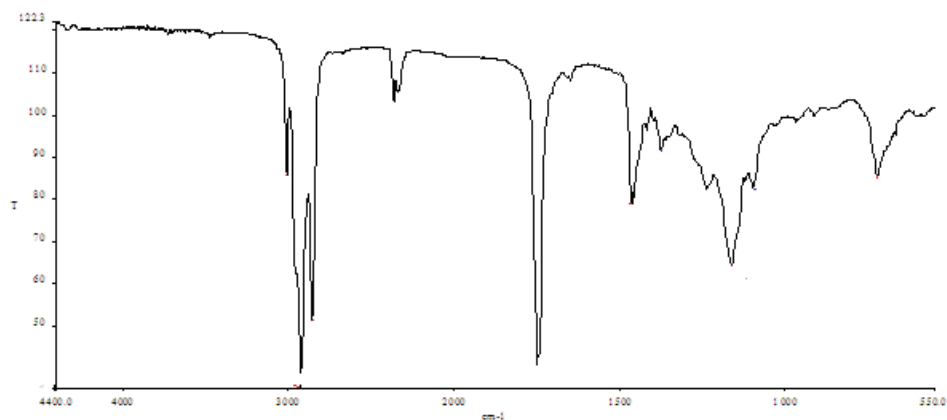

Fig. 9. FT-IR spectrum of soybean oil

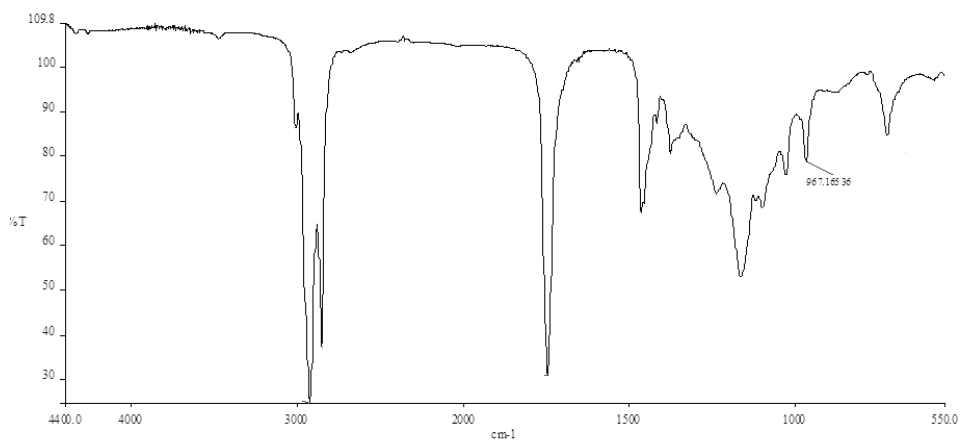

Fig. 10. FT-IR spectrum of cationically polymerized soybean oil after 6 hours of reaction. Catalyst: HBF_4 1%; temperature: 90 °C.

Figures 11 and 12 show ^1H NMR spectra of initial soybean oil and of cationically polymerized soybean oil after 6 hours of the reaction. They give important information on the possible mechanism of cationic polymerization soybean oil.

The decrease of double bond content at chemical shift of 5.42 ppm is evident. A strong decrease of mono-allyl (2.16 ppm) and bis-allyl (2.63 ppm) hydrogen atom concentrations observed in polymerized soybean oil suggests that they play an important role in the cationic polymerization. The mono-allyl and bis-allyl positions in fatty acids of soybean oil are displayed in Figure 13. Mono-allyl hydrogens are attached to a carbon atom linked to a double bond and bis-allyl hydrogen atoms are linked to a carbon atom between two double bonds. Thus, oleic acid has two mono-allyl positions, linoleic acid has two mono-allyl and one bis-allyl positions and linolenic acid has two mono-allyl and two bis-allyl positions.

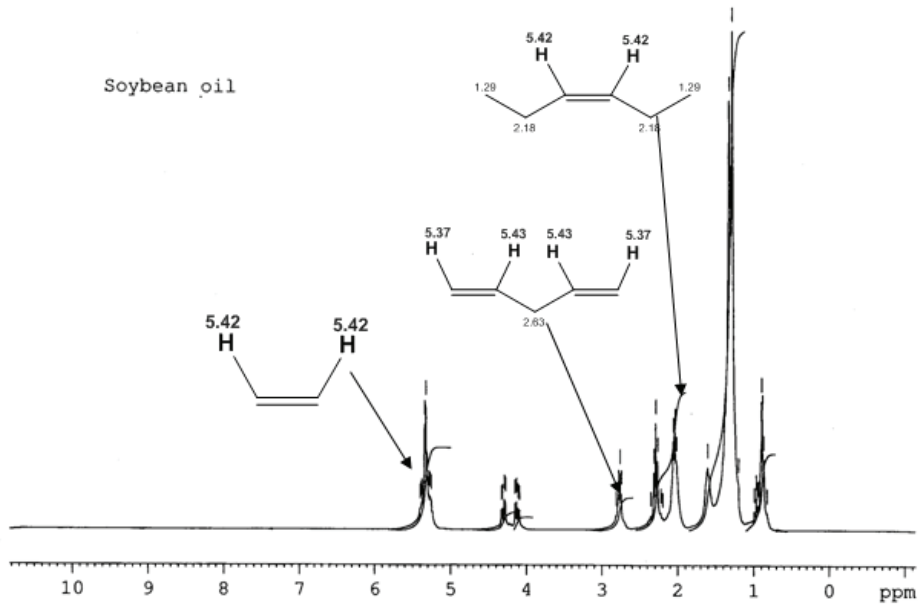

Fig. 11. ^1H NMR spectrum of initial soybean oil

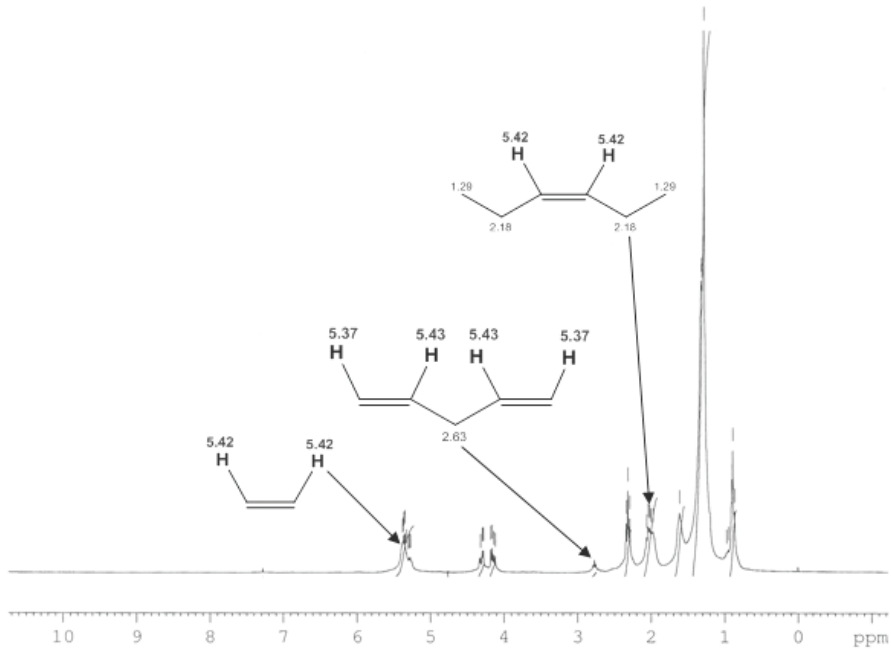

Fig. 12. ^1H NMR spectrum of polymerized soybean oil after 6 hours of reaction. Catalyst: HBF_4 1%; temperature 90°C .

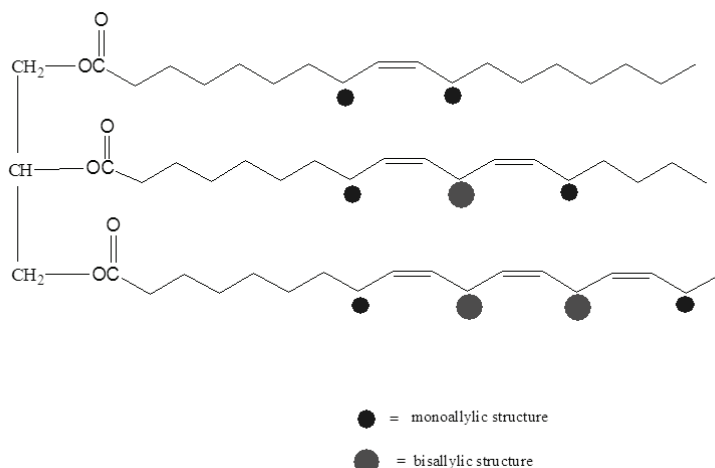

Fig. 13. The mono-allyl and bis-allyl positions in fatty acids of soybean oil.

4. The proposed mechanism for cationic polymerization of soybean oil

Based on the data presented, we propose a mechanism of cationic polymerization of soybean oil, which proved to be unconventional and different from the classical cationic polymerization of olefins.

The classical cationic polymerization of olefins activated by electron releasing substituents (vinyl ethers, isobutylene, vinyl carbazol etc) starts with the formation of carbocations resulting from the reaction of acid catalysts with double bonds of a monomer (SCHEME II).



Scheme II. Formation of a carbocation by the attack of a proton on the olefin double bond

The formed carbocations attack double bonds, step by step, generating macrocations (polymers terminated with a carbocation active center) as shown in SCHEME III.

Internal 1,2 disubstituted double bonds are of much lower reactivity in cationic polymerization and do not follow the classical pathway presented in SCHEME II and SCHEME III. To prove that, we carried out the cationic polymerization of 9-octadecene, a model compound having an internal 1,2 disubstituted double bond (SCHEME IV).

Gel Permeation Chromatograms of initial 9-octadecene and after 6 hours of cationic polymerization are presented in Figure 14. The catalyst was triflic acid as the best superacid for soybean oil polymerization, at 90 °C. Surprisingly no oligomers or polymers were formed after 6 hours of reaction. The initial monomer was recovered unchanged.

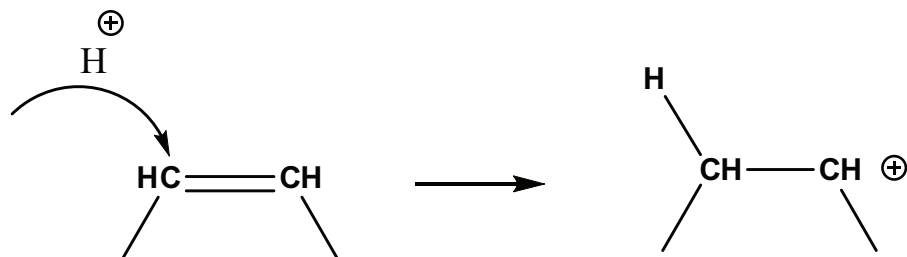

Scheme V. Formation of a carbocation in the reaction of a proton from superacids with the double bond of soybean oil

The next step is not the attack of the formed carbocation on a new double bond, but the transfer reaction of carbocations with hydrogen atoms from mono-allyl and especially from bis-allyl positions. The hydrogen atoms in allyl and bis-allyl positions are very labile and easily react with reactive carbocations forming allyl cations, which we consider to be the key species in cationic polymerization of soybean oil (SCHEME VI). The transfer reaction by abstraction by reactive carbocations of hydride anions from structures with labile hydrogen atoms (hydrogen atoms from allyl or benzyl positions) is a general reaction of carbocations.

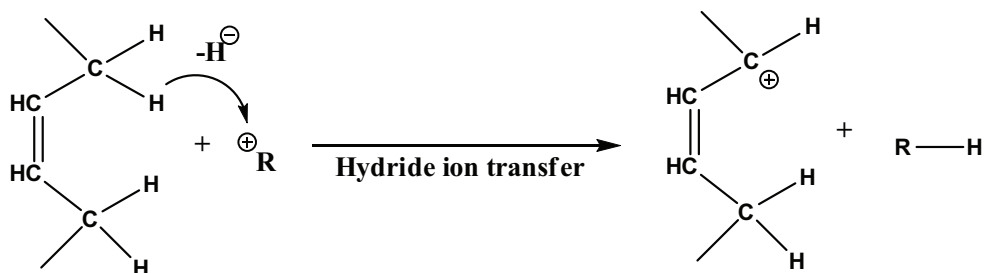

Scheme VI. Formation of allyl cations by transfer reaction of carbocations with the hydrogen atoms from allyl positions

Allyl cations are very stable due to the hybrid resonance, since practically the positive charge is distributed among 3 carbon atoms (SCHEME VII). As a consequence, the allyl cations have a much lower reactivity than the carbocations formed by addition of a proton to a double bond. This is the reason why the olefins having allyl positions do not polymerize cationically. Due to this transfer reaction, allyl protons disappear during cationic polymerization of soybean oil as was observed in ^1H NMR spectra. Thus, transfer reactions of carbocations with allyl protons play a major role in cationic polymerization of soybean oil.

The resonance structures formed in the case of transfer reactions with hydrogen atoms of bis-allyl position are more complicated in the case of linoleic acid, since the positive charge is extended to 5 carbon atoms as shown in SCHEME VIII. They lead to the formation of conjugated double bonds, which are around 4 Kcal/mol more stable than nonconjugated double bonds. Transfer reactions of these cations with other bis-allyl protons lead to other conjugated double bonds which participate in Diels Alder reactions, mainly with allyl cations.

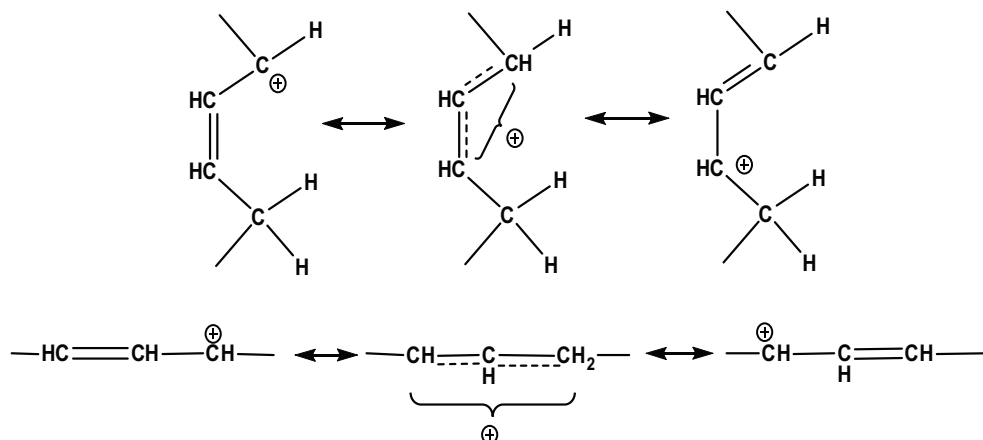

Scheme VII. Resonance hybrids of allyl cations

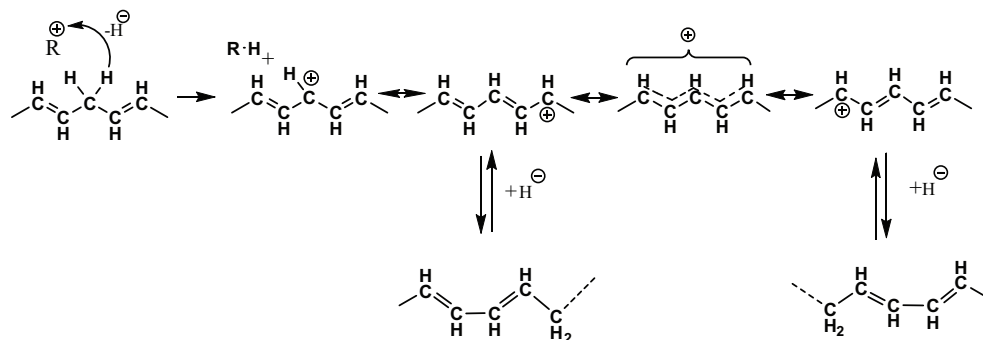

Scheme VIII. Transfer reactions of carbocations with bis-allyl protons of linoleic acid leading to the formation of conjugated double bonds.

In the case of linolenic acid, the transfer reaction of hydrogen atoms from both bis-allyl positions can generate allyl cations with resonance structures having two positive charges distributed over 7 carbon atoms. Conjugated double bonds in linolenic structures are formed in a similar way as in linoleic acid. The resonance hybrids in the case of allyl cations derived from linolenic acid chains are presented in SCHEME IX.

One of the most important properties of electron deficient species such as allyl cations is to participate easily in Diels Alder reactions, which are a part of the group of pericyclic reactions characterized by a cyclic transition state. There is significant literature data on Diels Alder reactions of allyl cations (Beatriz de Pascual,1996, Gassman & Lottes 1986, Gassman &Becker 1992, Gassman 1992, Deno,1970). An allyl cation can react with an isolated double bond (e.g., from oleic acid) forming a cyclobutane ring ($2\pi+2\pi$ Diels Alder cycloaddition reaction), or to react an allyl cation with a 1,3 diene structure (conjugated double bonds) forming a 6-membered cycle ($4\pi+2\pi$ Diels Alder cycloaddition reaction), or to react an allyl radical with conjugated double bonds and form a seven-membered cycle ($4\pi + 3\pi$ Diels Alder cycloaddition reaction). This last Diels Alder reaction is recognized as a general

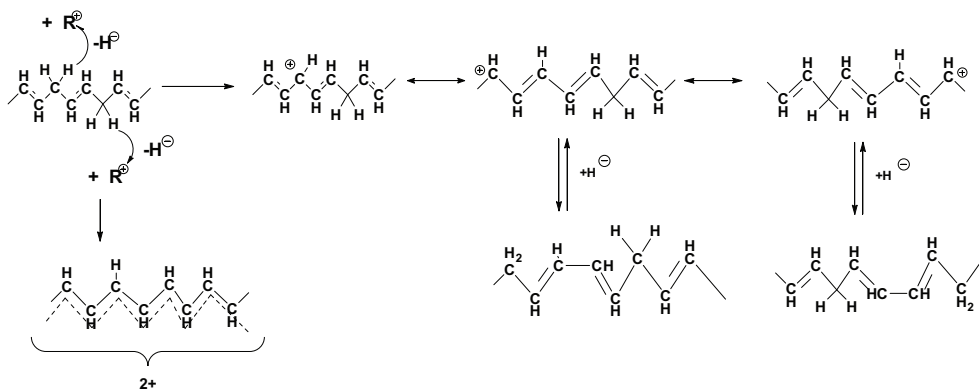

Scheme IX. Transfer reactions of carbocations with “bis” allyl protons of linolenic acid and the formation of conjugated double bonds

method for synthesis of 7 membered cyclic compounds. Schematically, these types of Diels Alder reactions of allyl cations are presented in the next SCHEMES X, XI and XII. It is well known that in Diels Alder reactions are two partners: one rich in electrons (for example dienes) and one deficient in electrons, in our case allyl cations. Of course allyl cations as any cationic species, are deficient in electrons with a big affinity for the species rich in electrons.

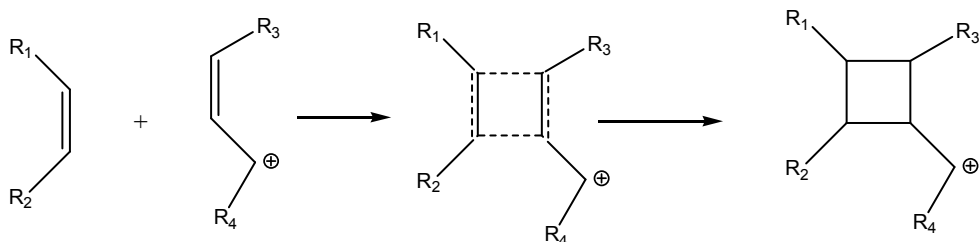

Scheme X. $2\pi+2\pi$ cycloaddition Diels Alder reaction of allyl cations

Diels Alder reactions with formation of cyclobutane rings are less probable (but not impossible) due to very high angular strain of cyclobutane ring and due to the lower reactivity of an isolated double bond as compared with conjugated double bonds in pericyclic reactions. Formation of cyclobutane rings was observed in cationic polymerization of oleic acid and derivatives with BF_3 as a catalyst (Ghodssi,1970, Gassman &Lottes, 1992). The new nonconjugated carbocations formed as a consequence of Diels Alder reactions are very reactive species and participate easily in transfer reactions with mono-allyl and bis-allyl hydrogen atoms.

Another possible reaction involving allyl cations called “ene” reaction, may be involved in the cationic polymerization of soybean oil. “Ene” reactions, another pericyclic reaction, are very similar with Diels Alder reaction, and are appreciated as a powerful way to generate C-C bonds (SCHEME XIII). The “ene” reaction, characteristic to isolated double bonds, probably is carried out in a lesser extent. In the cationic dimerization or trimerization of unsaturated fatty acids with acidic clays only 5-6% reaction products are formed as a consequence of “ene” reaction the rest being cyclic compounds (cyclic dimer and trimer acids) as a consequence of Diels Alder reactions, which are predominant reactions.

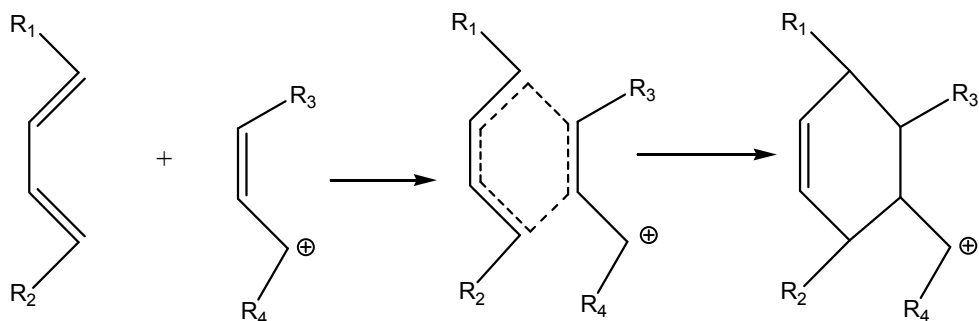
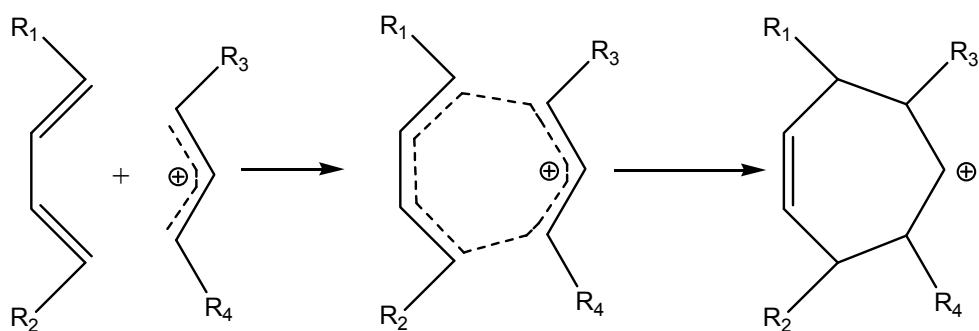
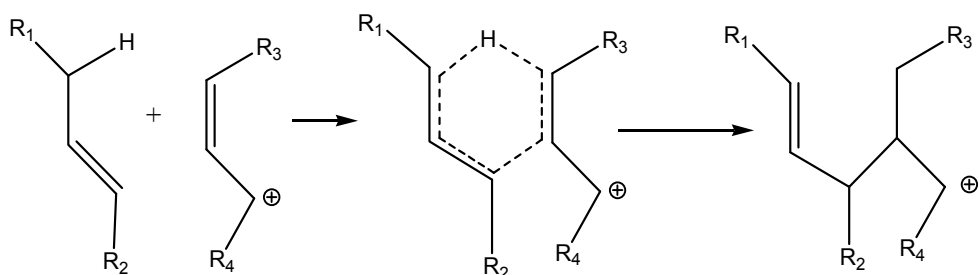
Scheme XI. $4\pi + 2\pi$ cycloaddition Diels Alder of allyl cationsScheme XII. $4\pi + 3\pi$ cycloaddition Diels Alder reaction of allyl cations

Scheme XIII. "Ene" reaction of allyl cations

In conclusion, the cationic polymerization of soybean oil is a reaction due to the allyl cations formed by transfer reactions of carbocations with mono-allyl and bis-allyl positions. The triglycerides structures are linked by various C-C bonds (in cyclic and acyclic forms), to branched oligomers and polymers as a consequence of Diels Alder and "ene" reactions of allyl cations.

Summarizing, the cationic polymerization of soybean oil has the following characteristic steps:

1. Formation of carbocations by addition of protons of superacids to double bonds of oil;
2. Transfer reaction of carbocations with the hydrogen atoms (hydride ion transfer) from mono-allyl and bis- allyl positions with formation of allyl cations, the "key" species in the cationic polymerization of soybean oil;
3. Diels Alder reactions of allyl cations with the double bonds and conjugated double bonds formed as a consequence of resonance hybrids of allyl cations in linoleic and linolenic structures. In that way the triglyceride fatty acid chains are linked by cyclic structures formed as a consequence of Diels Alder reactions;
4. In lesser extent, another pericyclic reaction of allyl cations, the "ene" reaction may take place, leading to a linkage between triglycerides chain by C-C bonds;
5. In parallel with polymerization reaction the rearrangement of "cis" double bonds of soybean oil to "trans" double bonds is carried out.

The rearrangement of "cis" double bonds to "trans" double bonds is possible due to the resonance hybrids of allyl cations too. In one resonance hybrid, the initial double bond becomes single bond, and it is permitted the free rotation around this bond (Deno et al 1970). The driving force of this free rotation is the repulsion between the alkyl substituent situated in "cis" position. Due to this free rotation are formed the "trans" isomer more stable than "cis" isomer (SCHEME XIV). As a general view of cationic polymerization of soybean oil, the formation of linkages between triglyceride units by Diels Alder and "ene" reactions and izomerization of "cis" double bonds to "trans" double bonds, all are a consequence of hybrid resonance structures of allyl cations.

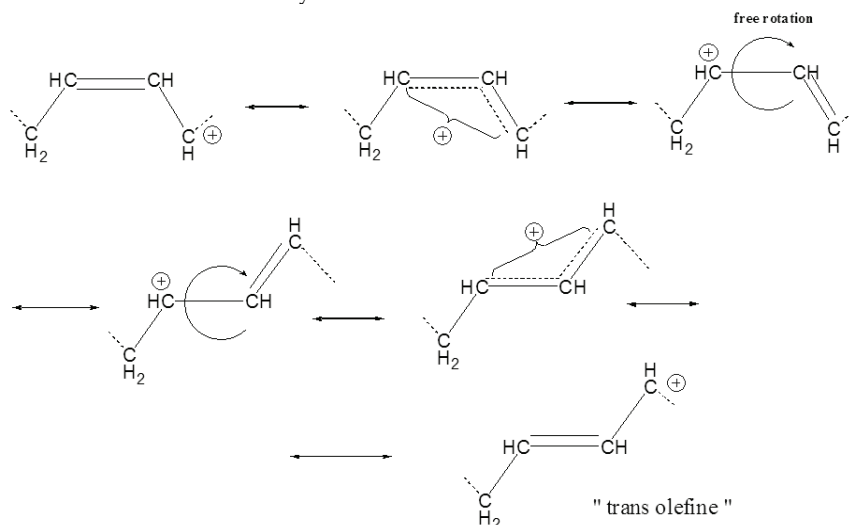

Scheme XIV. Rearrangement of "cis" double bonds to "trans" double bonds in cationic polymerization of soybean oil

Based on the proposed mechanism, the probable structure of polymerized soybean oil is presented in the next SCHEME XVI. Cationic polymerized soybean oil is a highly branched polymeric structure constituted by triglyceride units linked by C-C bonds from cyclic rings, predominantly six or seven membered rings as a consequence of Diels Alder reactions or by simple C-C bonds as a consequence of "ene" reactions, all reactions involving allyl cations.

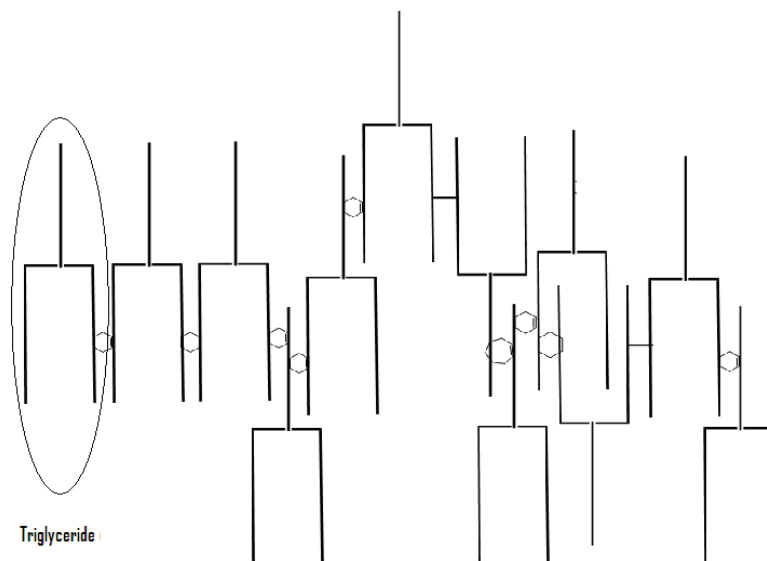

Scheme XVI. The structure of cationic polymerized soybean oil

Table 2 presents some characteristics of cationic polymerized soybean oil in comparison with heat bodied soybean oil and heat bodied linseed oil.

| No. | Characteristic | Cationic polymerized Soybean oil | Heat bodied Soybean oil | Heat bodied Linseed oil |
|-----|--|----------------------------------|-------------------------|-------------------------|
| 1 | Mn | 1900-3000 | 2300-2300 | 1800-2800 |
| 2 | Mw | 19000-42000 | 25000-35000 | 25000-75000 |
| 3 | Mw/Mn | 10-14 | 11-14 | 14-27 |
| 4 | Monomer, % | 26-31 | 11-18 | 21-30 |
| 5 | Oligomers, % | 68-72 | 77-78 | 68-75 |
| 6 | Free fatty acids, % | <1 | 4-9 | 2-4 |
| 7 | Iodine value, mgI ₂ /100g | 105-110 | 65-95 | 103-110 |
| 8 | Acidity, mg KOH/g | 2-3 | 7-9 | 9-10 |
| 9 | Viscosity, 25°C, Pa.s | 7-16 | 6-10 | 5.6-17 |
| 10 | Refractive index, n _D 25 °C | 1.476-1.481 | 1.478-1.480 | 1.4896 |

Table 2. Characteristics of cationically polymerized soybean oil in comparison with heat bodied soybean oil and heat bodied linseed oil.

5. Conclusions

A new process for cationic polymerization of soybean oil, catalyzed by superacids such as tetrafluoroboric acid, triflic acid and hexafluoroantimonic acid, is presented. The high yield, practically quantitative process produces viscous liquid or solid polymers depending on the reaction time. The reaction is carried out in mild reaction conditions: 80-100 °C and atmospheric pressure. In comparison with the heat bodied oils, the current process is more

economical. In comparison with "air blown" oils, cationic polymerization of oils produces only triglycerides fatty acid hydrocarbon chains linked by various C-C bonds, without carboxyl, aldehyde, ketone or hydroperoxide groups. We proposed an unconventional mechanism for cationic polymerization of soybean oil involving pericyclic reactions of allyl cations (Diels Alder and "ene" reactions), allyl cations being the "key" cationic intermediates. The relatively high content of double bonds makes the cationically polymerized soybean oil suitable for further crosslinking reactions useful for printing inks and rubber modifiers, but also as lubricants, compressor fluids etc.

6. References

- Beatriz de Pascual-Teresa & Houk K.N.(1996). Ionic Diels Alder of the Allyl Cation and Butadiene: Theoretical Investigation of the Mechanism, *Tetrahedron Letters*, 37(11), pp. 1759-1762. ISSN: 0040-4039.
- Bernstein I.M. (1946). Heat Polymerization of Nonconjugated Vegetable Oils, *Journal of Polymer Science*, 3(6), pp. 495-528. ISSN:0887-624X
- Christianson R et al (2007). Process for Preparing Blown Vegetable Oils, *US Patent 7262311*.
- Conroy N. (1972). Polymerization of unsaturated fatty acids, *US Patent 3,632,822*.
- Croston et al.(1952). Polymerization of Drying Oils:Catalytic Polymerization of Fatty Acids and Esters with Boron Trifluoride and Hydrogen Fluoride, *Journal of the American Oil Chemists Society*, pp. 331-333. ISSN:0003-021X.
- Deno N.C and all (1970). Energy Barriers for Rotation about Carbon-Carbon Bonds in Allyl Cations, *Journal of the American Chemical Society*, 92(22),6691-6693. ISSN: 0002-7803.
- Difranco (2000). Method for isolating oleic acid and producing linoleic dimer/trimer acids via selective reactivity,*WO Patent 0050528*.
- Eichvald E.(1939).Process for stabilizing fatty oil polymers, *US Patent 2,160,572*.
- Erhan S.Z & Bugby M.O.(1994). Polymerization of Vegetable Oils and Their Uses in Printing Inks, *Journal of the American Oil Chemists Society*, 71(11), pp. 1223-1226. ISSN: 0003-021X
- Erhan S.Z. & Bagby M.O.,(1998). Vegetable Oil-based offset printing inks, *US Patent 5713990*.
- Gassman P.G. & Lottes A.C (1992), Cyclobutane formation in the $2\pi+2\pi$ cycloaddition of allyl and related cations to unactivated olefins, *Tetrahedron Letters*, 33(2), pp. 157-160. ISSN: 0040-4039.
- Gassman P.G.& Singleton D.A. (1986). Control of regioselectivity in ionic Diels-Alder Reactions. The use of Allylic Alcohols and Allylic Ethers as Precursor of Dienophylic Allyl Cations, *Journal of Organic Chemistry*, 51, pp. 3075-3076. ISSN: 0022-3263.
- Gassman P.G.(1992). Carbocation (cationic) and Cation Radical Promoted Diels-Alder Reactions Controlling the selectivity in Low Temperature $2\pi+4\pi$ Cycloadditions, *Mod.Methodol.Org.Synth.,Proc.Int. Symp. Org.React.*, 11-28.
- Geiger E & Becker N. (2006). Novel Polyol Derived from Vegetable Oils Using Oxidation Process, *WO 2006094227*.
- Ghodssi et al. (1970). Cationic Polymerization of Oleic Acid and its Derivatives. Study of Dimers. *Bulletin de la Société Chimique de France*, 4, pp. 1461-1466.ISSN: 0037-8968.
- Hall N.F. & Conant J.B. (1927). A Study of Superacid Solutions, *Journal of the American Chemical Society*, 49 (12), pp. 3047-3061. ISSN: 0002-7803.
- Hammett L.P. & Deyrup A.J. (1932). A Series of Simple Indicators. I. The Acidity Functions of Mixtures Sulfuric Acid and Perchloric Acid with Water" *Journal American Chemical Society*, 54 (7), pp. 2721-2739.

- Hayes K.S.(1986). Polymerization of fatty acids, *GB Patent 2,172,597*.
- Ionescu M & Petrović Z. (2009). Polymerization of Biological Oils with Superacids, *US Patent 7,501,479*
- Ionescu M. (2005). Polyols from renewable resources. *Chemistry and Technology of Polyols for Polyurethanes*, pp.435-470, Edited by RAPRA, UK. ISBN:1-85957-501-3.
- Larock R. C.& Li F.(2000). Thermosetting Polymers from Cationic Copolymerization of Tung Oil: Synthesis and Characterization. *J. Appl. Polym. Sci.* 78, pp. 1044. ISSN:0021-8995.
- Larock R. and Hanson Mark (2001). Lewis-acid catalyzed polymerization of biological oils and resulting polymeric materials, *US Patent 6,211,315*.
- Li, F. & Larock R. C (2000). New Soybean Oil-Styrene-Divinylbenzene Thermosetting Copolymers. II. Dynamic Mechanical Properties, *J. Polym. Sci. Part B: Polymer Physics*, 38, 2721. ISSN:0887-6266.
- Li F.& Larock R. C.(2001).(a) New Soybean Oil-Styrene-Divinylbenzene Thermosetting Copolymers. III. Tensile Stress-Strain Behavior, *J. Polym. Sci. Part B: Polymer Physics*, 1, pp. 60. ISSN:0887-6266.
- Li F.& Larock R. C.(2001). (b) New Soybean Oil-Styrene-Divinylbenzene Thermosetting Copolymers. I.Synthesis and Characterization, *J. Appl. Polym. Sci.*, 80, 658. ISSN:0021-8995.
- Li F., Larock R. C & Otaigbe J. U.(2000). (a) Fish Oil Thermosetting Polymers: Creep and Recovery Behavior, *Polymer*, 41, pp. 4849. ISSN: 0032-3861.
- Li F., Larock R. C & Otaigbe J. U.(2000).(b) Fish Oil Thermosetting Polymers: Synthesis, Structure, Properties and Their Relationships, *Polymer*, 41, pp. 7925. ISSN: 0032-3861.
- Li F., Hanson M. V & Larock R. C.(2001). Soybean Oil-Divinylbenzene Thermosetting Polymers: Synthesis, Structure, Properties and Their Relationships, *Polymer*, 42, 1567.
- Milks J.E. & Conroy N.(1969). Two stage polymerization of unsaturated fatty acids, *US Patent 3,422,124*.
- Olah G.A. & Schlosberg R.H. (1968).Chemistry in Superacids, *Journal of the American Chemical Society*, 90, pp. 2726-2727. ISSN: 0002-7803.
- Olah G.A. et all. (1985). *Superacids*, John Wiley and Sons, (1985: 405629).
- Olah G.A. et all. (2009). *Superacid Chemistry* (second Edition), Wiley-Interscience, ISBN: 978-0-471-59668-4.
- Petrović Z.(2008). Polyurethanes from vegetable oils, *Polymer Reviews*, 48(1), pp.109-155. ISSN: 1558-3724.
- Powers P.O. (1950). Mechanism of the Heat Bodying Linseed Oil, *Journal of Polymer Science*, 5(6), pp. 741-743.
- Turner S.W. & Blewett C.W.,(1990). Process for production of polybasic acid esters with recovery of boron trifluoride, *US Patent 4,973,743*.
- Uloth M..(1944). Agents suitable for improving lubricants, *US Patent 2,365,919*.
- Vreswijk J. & Haase K.D. (1990). Dimerized fatty acids having high content of dicarboxylic acid, *US Patent 4,937,320*.
- Wang C. & Erhan S. (1999).Studies of Thermal Polymerization of Vegetale Oil with a Differential Scanning Calorimeter, *Journal of the American Oil Chemists Society*, 76(10), pp. 1211-1216. . ISSN: 0002-7803.
- Wheeler D.H (1969). Magnesium silicate catalyzed polymerization of unsaturated fatty acid, *US Patent 3,444,220*
- Liu, Z., Brajendra S. & Erhan S. (2007). From Oligomers to Molecular Giants of Soybean Oil in Supercritical Carbon Dioxide Medium, *Biomacromolecules*, 8, pp. 233-239, ISSN : 1525-7797.

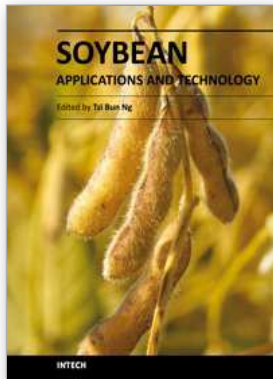

Soybean - Applications and Technology

Edited by Prof. Tzi-Bun Ng

ISBN 978-953-307-207-4

Hard cover, 402 pages

Publisher InTech

Published online 26, April, 2011

Published in print edition April, 2011

Soybean is an agricultural crop of tremendous economic importance. Soybean and food items derived from it form dietary components of numerous people, especially those living in the Orient. The health benefits of soybean have attracted the attention of nutritionists as well as common people.

How to reference

In order to correctly reference this scholarly work, feel free to copy and paste the following:

Ionescu Mihail and Petrović S. Zoran (2011). Polymerization of Soybean Oil with Superacids, Soybean - Applications and Technology, Prof. Tzi-Bun Ng (Ed.), ISBN: 978-953-307-207-4, InTech, Available from: <http://www.intechopen.com/books/soybean-applications-and-technology/polymerization-of-soybean-oil-with-superacids>

INTECH

open science | open minds

InTech Europe

University Campus STeP Ri
Slavka Krautzeka 83/A
51000 Rijeka, Croatia
Phone: +385 (51) 770 447
Fax: +385 (51) 686 166
www.intechopen.com

InTech China

Unit 405, Office Block, Hotel Equatorial Shanghai
No.65, Yan An Road (West), Shanghai, 200040, China
中国上海市延安西路65号上海国际贵都大饭店办公楼405单元
Phone: +86-21-62489820
Fax: +86-21-62489821

© 2011 The Author(s). Licensee IntechOpen. This chapter is distributed under the terms of the [Creative Commons Attribution-NonCommercial-ShareAlike-3.0 License](#), which permits use, distribution and reproduction for non-commercial purposes, provided the original is properly cited and derivative works building on this content are distributed under the same license.

Sourdough and Bread Properties as Affected by Soybean Protein Addition

Josué Peñaloza- Espinosa, Gloria J. De La Rosa-Angulo,
Rosálva Mora-Escobedo, Jorge Chanona-Pérez,
Reynold Farrera-Rebollo and Georgina Calderón-Domínguez
*Escuela Nacional de Ciencias Biológicas, Instituto Politécnico Nacional
México*

1. Introduction

Soybean benefits in human health have been the target of numerous studies during the last decades. This interest has been the result of the findings about soybean consumption, where this legume or some of its components, mainly proteins and isoflavones, have been related to the reduction of some human diseases, such as cardiovascular diseases, diabetes, obesity, hypertension, dyslipidemia or even cancer (Piñeiro, 2006; Martin, 2001; Barnes, 1995).

Soybean is an economically important crop, which usually has served as a source of energy and good-quality protein for animals and humans, as it presents a high content of protein (36-48%), lipids (18-21%) and carbohydrates (33.5%), besides the amount of crude fibre and non saturated lipids which make them to be considered as healthy foods (Chávez et al., 1992). Moreover, a number of nutrients and micronutrients with nutraceutical properties have been identified in soybean, including isoflavones, phytosterols, inositol hexaphosphate, saponins, protease inhibitors, and bioactive peptides (Barnes, 1995; Hawrylewicz et al., 1995; Kennedy, 1995; Rao & Sung, 1995; Badger et al., 2005; Gálvez et al 2001; Vucenik et al., 2003; Badui, 1993).

Nowadays, different kinds of foods containing soybean flour or some of its products can be found in the market, being bread one of these items. Adding soybean to bread has been proposed to improve its nutritional quality, however, the level of soybean addition has been restricted to less than 10%-15% (wheat flour basis) as detrimental effects on bread quality (lower bread volume, coarser crumb structure, and a stronger flavour) have been reported (Sabanis & Tzia, 2009; Olaoye et al., 2003; Dhingra & Jood, 2004; Shogren et al., 2003; Halle et al, 2004). This effect makes necessary to keep looking for other alternatives that allow higher levels of addition of this legume in bread making.

Sourdough breads are very popular foods worldwide. They are a mixture of flour (rye and wheat) and water that is fermented with lactic acid bacteria (LAB), mainly heterofermentative strains, which generate, as fermentation by-products, lactic and acetic acids and hence resulting in a sour taste of the end product. At the same time, yeast fermentation takes place, resulting in the dough expansion. The action of both microorganisms determines the sourdough bread characteristics in terms of acid production, aroma and leavening, resulting in an improvement of the volume, texture, flavour, nutritional value and shelf life of bread. These

characteristics make sourdough bread a very good alternative for being added with soybean flours or isolates, as the soybean off flavours could be less noticeable because of the stronger taste and aroma of this kind of bread. The aim of this work was to evaluate the effect of the addition of soybean isolate (0, 12.5 and 25%) as well as the effect of varying the starter fermentation time (0, 24 and 48h) on dough extensographic and farinographic properties and sourdough bread quality.

2. Materials and methods

Materials

A commercial soybean isolate (Cenit, Mex, 90 g protein/100 g sample (db)) and commercial wheat flour (11.0 g protein/100 g sample (db), N×5.7,) with a farinographic water absorption value of 58.1 g water per 100 g flour were employed. This type of wheat flour is suitable for traditional sourdough bread products. All other ingredients like table salt (La Fina, Sales del Itsmo, Mex), sugar (Great Value, Wal-Mart, Mex), white rye flour (ConAgra Foods, Inc, Omaha, NE), skim milk powder (Svelty, Nestle), dry instant yeast (Nevada Oro, Safmex), caraway seeds (*Carum carvi*, Terana, Mex) and extra virgin olive oil (Borges, Tarrega, Spain) were also commercial grade.

Wheat-soy isolate flour samples

Soybean isolate was added to complete 100 g of wheat flour at three different concentrations (0, 12, 25g).

Farinographic measurements

The farinograms of wheat-flour-soy isolate mixtures added or not with rye flour (18.5%), as well as the full sourdough bread formulations were acquired in a 300g Brabender Farinograph (Brabender OHG, Duisburg, Germany), obtaining, for all these samples, the farinographic water absorption, the maximum consistency time and the dough stability.

Extensographic measurements

The extensographic properties of the wheat flour- soybean mixtures with or without rye flour were determined in a Brabender extensograph (Brabender Duisburgh, T150, Germany) obtaining the maximum resistance to extension (R_{max} , UB) and extensibility (L , mm) at three different resting time (45, 90, 135 min) as reported by the manufacturer.

Bread making procedure

Sourdough bread was prepared following a traditional three steps method which includes obtaining the starter, the sourdough and finally the bread dough. Three different starters were obtained by fermenting (Precision Scientific, USA) a mixture of wheat flour (48.01g), active dry yeast (2.81 g), skim milk powder (2.95g) and tap water (46.2g) for different times (0, 24, 48h) at constant temperature ($28\pm 1^\circ\text{C}$). Once the selected fermentation time was completed a portion of the starter (31.4 g) was mixed with rye flour (38.1g) and tap water (30.5g) resulting in the sourdough after fermenting it for 24h at 30°C . The bread dough was prepared by mixing (Minor-pin mixer, Henry Simon Limited, Cheshire UK) all dry ingredients for 1 min: wheat flour-soy isolates mixtures (42.69g), caraway seeds (0.27g), dry active yeast (1.04g), table salt (1.09g) and sugar (1.64g). Then the olive oil (1.09g) and the sour dough (28.79 g) were added to the other ingredients and mixed for another minute. Finally tap water (30°C) was added and all ingredients were mixed until optimum dough

development, as obtained from the farinographic evaluation of full sour bread formulations. The quantity of water added to obtain the bread dough was based on the farinographic water absorption percentage at 500 Brabender Units (BU) of the wheat flour-soy isolates mixtures (Calderón-Domínguez et al., 2003). After mixing, dough was weighed (50 g), rounded by hand, and placed into an adapted fermentation chamber (Precision Scientific, USA) at constant temperature (30 °C) and humidity (85%) for 120 min. After this fermentation period, the dough was punched, rounded, moulded, placed into a baking pan (aluminium pudding mould), and left to rest for 60 min. Bread was baked at 210 °C for 20 min in a rotary oven (Henry Simon). Bread quality was analyzed considering loaf specific volume, colour, pH, titratable acidity, texture, crumb-grain structure and consumer acceptance.

Loaf specific volume

Loaf weight was measured immediately after baking, and loaf volume was evaluated 120 min later, using the rapeseed displacement method (AACC 2000, 10-05).

Colour

Crust and crumb colour were evaluated using a colorimeter (CR-400 Chroma metre, Konica Minolta, USA) with a D65 illumination source and at a 0° viewing angle. Luminosity (L*), $\pm a^*$ and $\pm b^*$ values were obtained (Rosales-Juárez et al., 2008). Colour was measured on five different points on each sample, taking them in the central and outward parts of the loaf, avoiding its edges.

pH and titratable acidity

pH was measured by dispersing 10 g of sample in 100 mL of cool, recently boiled water (25°C) and employing a potentiometer equipment (Hanna Instruments, Rumanía). Titratable acidity was evaluated following the 02-31 AACC method (2000).

Texture evaluation

Texture analysis was carried out in a Texture Analyzer-TX2 (Stable Micro Systems Ltd., UK), applying a double compression test and employing a 1.5" (3.81 cm) diameter acrylic cylinder probe (TA-11) as cited by Rosales-Juárez et al., (2008). Cross head's speed was set at 5 mm/s, and the analysis was carried out 18 h after baking. Samples were prepared by cutting the loaf crust off to obtain a 3-cm height sample, allowing only crumb texture measurements. Bread slices were compressed to 50% of their original height. The type of probe was chosen to avoid the effect of loaf edges. Reported textural parameters were: compression force (g), firmness (g), and resilience.

Crumb grain evaluation

Crumb grain characteristics were evaluated by an image analysis technique following the methodology reported by López-Guel et al., (2009). All samples were allowed to cool for at least 2 hours at room temperature (20°C) and kept inside polyethylene hermetic bags to avoid moisture loss until they were analyzed for crumb structure which was performed 24 hours after baking. Breads were cut in halves with an electric knife (Moulinex Classic 012, France). Bread crumb images were obtained by scanning the samples at a resolution of 550 dpi in a BenQ 5000 colour scanner (colour depth 48 bit, optical resolution 1,200 dpi×2,400 dpi). Images were saved as bitmap files and they were cropped using the ImageJ software (National Institutes Health, Bethesda, MD, USA) to obtain a field of view (FOV)

representing a 65% of the total crumb bread area. Cropped colour images were converted into an 8-bit greyscale images. Thresholding was carried out by means of the Otsu algorithm (Gonzales- Barron & Butler 2006), using the ImageJ software. Count and measurements of cells were done using the Sigma Scan Pro 5.0 software to get the total cells number of the cropped image, pore size (overall mean cell area), number of pores per square centimetre (cell density), and circularity of pores (shape factor). The final data were processed in Excel 2003 software (Microsoft Office Corporation, USA) where a subdivision based on the pore size area (A) for all the parameters measured was established: all pores, $A > 0.002 \text{ mm}^2$, $0.002 < A < 4 \text{ mm}^2$ and $0.004 < A < 4 \text{ mm}^2$.

Sensory analysis

A multi-sample likeability rating test, as reported by Rosales-Juárez et al., (2008), was carried out on two selected samples, where a hedonic scale (seven levels of acceptance) was used, asking to grade the samples with values from 7 for the "like very much" level of acceptance down to 1 for the "dislike very much" level of acceptance. The evaluation was performed with a panel that consisted of 55 non-trained adults (30 ± 13 years old) as the product was intended for adults that want to consume healthy products. Loaf samples were sliced with an electric slicing knife (Moulinex Classic 012, France), discarding crusts. Both samples were labelled with a three-digit random code.

Experimental design

A 3^2 factorial design, with three repetitions of each sample, was used. Two factors were analyzed (soy isolate level and fermentation time) at three different levels (Table 1). Selected responses were farinographic and extensographic parameters, bread quality (specific volume, colour, texture, crumb structure), and dough titratable acidity and pH. These responses were expressed individually as a function of independent variables. The experimental sequences, the data analysis and the response surface plots were obtained from the Design Expert Program software, version 6.0 (Stat-Ease Inc., Minneapolis, USA). Sensory analysis and biological evaluation data were analysed using SigmaStat 3.5 for Windows (Systat Software, Inc. USA), using ANOVA and the Holm-Sidak method or Tukey test as obtained from the software. $P < 0.05$ was considered to be significant.

| Factor | Code | Levels | | |
|-----------------------|------|--------|------|----|
| WA (%) | | -1 | 0 | +1 |
| Soybean isolate (%) | SI | 0 | 12.5 | 25 |
| Fermentation Time (h) | FT | 0 | 24 | 48 |

Table 1. Response surface experimental design

SDS-PAGE electrophoresis

The effect of mixing, fermentation and baking on the protein structure of the two best sourdough samples was studied by SDS-PAGE electrophoresis. Proteins were extracted following the methodology proposed by Tuukkanen et al., (2005) with some modifications. Prolamins were obtained by mixing (30 min, 52°C) 0.1g of the dry defatted sample with 1mL of 70% ethanol solution (v/v) and keeping to analyze the soluble fraction as obtained after centrifugation ($11000 \times g$, 4°C , 10 min). Albumins and globulins were extracted by mixing (10 min, vortex) 0.1g of sample (dry and defatted) with 1 mL of a 0.5M NaCl solution (w/v) and keeping the liquid phase after centrifugation ($11000 \times g$, 10 min, 4°C). Glutelins were

obtained by mixing (10 min, vortex) 0.1 g of sample (dry and defatted) with 1 mL of 0.05M acetic acid solution (w/v) and analyzing after centrifugation (11000 x g, 10 min, 4°C) the supernatant. SDS-PAGE electrophoresis was conducted in a 250 Mighty Small II electrophoresis unit (Hoeffer, USA) using resolving gels with different concentration of total acrylamide (%T). An 11%T resolving gel was used to study the prolamin and glutelin fractions, while a 16%T resolving gel was employed to separate NaCl soluble fraction. The analysis was carried out at non reducing conditions and at 110 V (25 mA) and loading 20 µL each protein sample. A low molecular weight protein marker (5 µL) and BSA (5 µL) were included as protein markers.

Biological analysis

Male and female 21 days old albino Wistar rats, weighting an average of 68±10g were used for evaluating the protein quality of the two selected breads. All animals were allowed a 5-day adaptation period after receipt. After this 5-day period, rats were weighted and fed (ad libitum) with water and with a diet containing 10% protein and 90% of a mix which was composed of 1% of vitamins, 10% corn oil, 5% non nutritive cellulose, 4% minerals and corn starch to complete the mix. The laboratory conditions were kept at controlled temperature and moisture under 12h light and 12h dark. Diets were weighted everyday during the experiment and the rats were weighted on each seven days. The feed intakes were calculated weekly over the 28-day experimental period, except the protein free groups that lasted 14 days. Faeces were collected from the 7th to the 14th days of experiment. The biological indexes were determined from the results of the weight gain, the total amount of protein consumed, the total amount of diet consumed, and the total nitrogen excreted in the faeces. The biological indexes calculated were: protein efficiency ratio (PER), net protein ratio (NPR), apparent digestibility (AD) and true digestibility (TD).

3. Results and discussion

Farinographic and extensographic parameters of flours.

Table 2 shows the results of the farinographic and extensographic evaluation of the flours used in the bread making process (wheat, wheat-rye, and wheat- soybean isolate- rye).

| Farinographic & Extensographic parameters | Flours | | | |
|---|------------|------------|----------------------|-------------------|
| | Wheat | Wheat-Rye | Wheat-Soy 12.5%- Rye | Wheat-Soy 25%-Rye |
| WA (%) | 58.1 | 61.0 | 68.0 | 71.0 |
| MCT (min) | 10.3 ± 0.1 | 15.1 ± 0.5 | 11.3 ± 0.4 | 10.5 ± 0.7 |
| S (min) | 19 ± 0.8 | 16.4 ± 0.8 | 6.5 ± 0.4 | 6.3 ± 0.4 |
| L _{135 min} (mm) | 140 ± 11 | 140 ± 7 | 101 ± 6 | 82 ± 5 |
| R _{max 135 min} (BU) | >1000 | 745 ± 41 | 653 ± 59 | 540 ± 14 |

L and Rmax were evaluated after 135 min of resting time.

Table 2. Farinographic and extensographic results. (WA: water absorption. MCT: maximum consistency time. S: stability. L: extensibility. Rmax: maximum resistance to extension).

Water absorption (WA), which represents the amount of water required to centre the farinogram curve on the 500 BU line, increased when adding rye flour or the soybean isolate as a result of the larger level of protein. This information is in agreement with the reports of Rosales-Juárez et al., (2008) and López-Guel et al., (2009). WA data was used to calculate the quantity of water to add in the full bread formulations. Table 2 also presents the results of dough maximum consistency time (MCT) where it can be seen that the addition of rye flour increased the time required to obtain an optimum developed dough, while the addition of the soybean isolate decreased this parameter, maybe as a consequence of the less gluten proportion in the formulation. The dough stability (S) showed a decrement in their values as soybean isolate or rye flour was increased. On the other hand, extensographic information showed that the addition of rye flour or soybean isolate decreased both the extensibility (L_{135}) and the maximum resistance to extension (R_{max}). Hegazy & Faheid (1990) reported that adding soybean flour promotes a decrement in wheat dough extensibility, which is in accordance with our results. However it has been reported in other works that the addition of soybean flour increased this parameter (Rosales-Juárez et al., 2008). These differences could be explained as a result of the larger levels of soybean isolate used in our bread formulations as compared to the lower levels of the other studies. The addition of soybean isolate or rye flour also resulted in a decrement in the maximum resistance to extension (R_{max}). Similar results have been published by Indrani et al., (1991) and Maforimbo et al., (2008).

Farinographic maximum consistency time and stability of full bread formulations

The time required to obtain an optimum developed bread dough was determined by farinographic evaluation. Dough stability was also evaluated. Figure 1 shows these results.

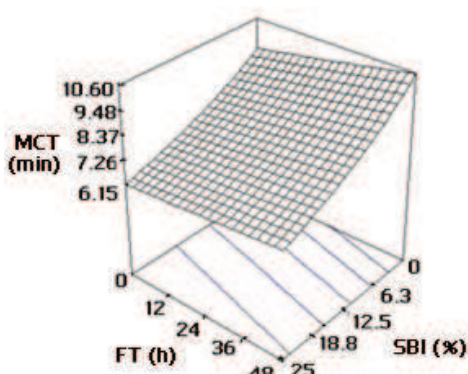

Fig. 1-A

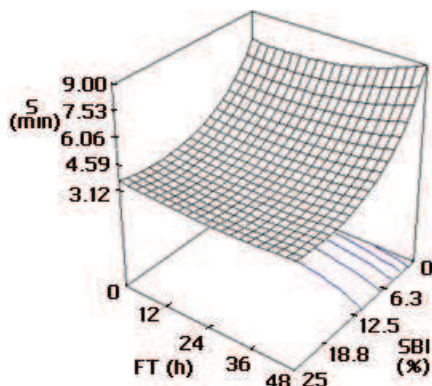

Fig. 1-B

Fig. 1. Effect of fermentation time (FT) and soybean isolate concentration (SBI) on maximum consistency time (MTC)(A) and dough stability (S) (B) of the sour bread dough.

It can be seen from the figure that both variables had an effect on the sourdough bread maximum consistency time, being the soybean isolate the component which produced the largest changes by decreasing the response (MCT) as SBI increases. Statistical analysis showed that data could be fitted, to lineal model ($P < 0.0001$), with determination coefficient (R^2) of 0.9383 (Table 3). Figure 1 also shows the effect of fermentation time and soybean isolate concentration on farinographic stability (Fig 1B). It can be observed from this graph

that this parameter decreased from 7.2 min to 3.4 min as soybean isolate increased, while fermentation time had a lesser effect. Stability data was fitted to a logarithmic model (Table 3) with a determination coefficient of 0.9575, having the proportion of soybean isolate a larger effect ($P < 0.0001$). When comparing the maximum consistency time or the farinographic stability of the full sourdough formulations (Figure 1A, 1B) against flours (Table 2), it was noticeable that the first one presented smaller values in both parameters for all formulations. The decreasing effect of soybean isolate in sourdough full bread formulations is contradictory to the information reported by other authors (López-Guel et al., 2009). This difference could be ascribed to very different proportion of soybean protein used in both works, being the effect over the wheat gluten network very different.

Effect on soybean isolate addition and fermentation time on pH and titratable acidity

Figure 2 shows the change of titratable acidity (Fig 2A) and pH (Fig 2B) as affected by soybean isolate addition and fermentation time.

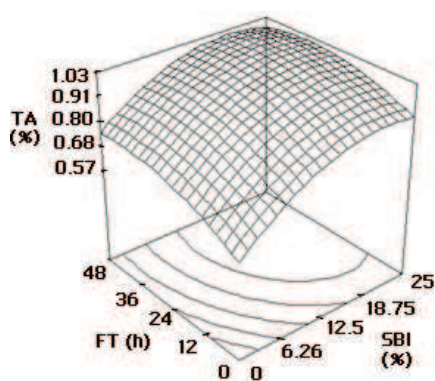

Fig. 2-A

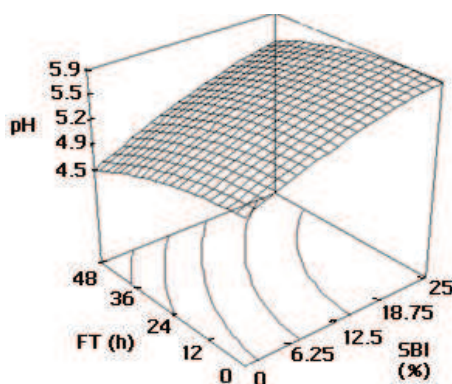

Fig. 2-B

Fig. 2. Changes on titratable acidity (TA) (A) and pH (B) of sourdough samples added with soybean isolate (SBI) and fermented for different times (FT).

It can be observed from Fig. 2 that both variables affected the responses ($P < 0.0001$). The statistical analysis showed that titratable acidity data can be fitted to a quadratic model ($P < 0.0001$, Table 3), with a determination coefficient of 0.9646, and increasing its value as the fermentation time and soybean isolate levels were risen. The sourdough bread pH follows a different trend, decreasing the pH values as fermentation time increased, but presenting larger values at higher soybean isolate proportions. These data were adjusted to a quadratic model too (Table 3), with a determination coefficient of 0.9983. It has been reported that a sourdough fermentation promotes the production of organic acids, and that these substances, along with the action of enzymes and microorganisms, could generate a proteolytic effect on the proteins of the soybean added, resulting in the formation of positively charged free amino acids, which could increase the pH value (Leon et al., 2006).

Bread specific volume

The effect of soybean isolate levels and fermentation duration on sourdough bread specific volume is shown in Fig. 3, where it can be noticed that the higher the soybean isolate concentration the less the bread loaf volume is ($P < 0.0001$). Statistical analysis showed that the

effect of fermentation time was non significant on this response ($P>0.05$). Similar results have been reported by different authors (López-Guel et al., 2009; Indrani et al., 1997; Hallen et al., 2004), who cited that the smaller loaf specific volumes of soybean breads could be the result of a decrement in the gas retention capacity of the gluten network. Specific volume data was fitted to a quadratic model ($P<0.0001$) with a determination coefficient of 0.9649 (Table 3).

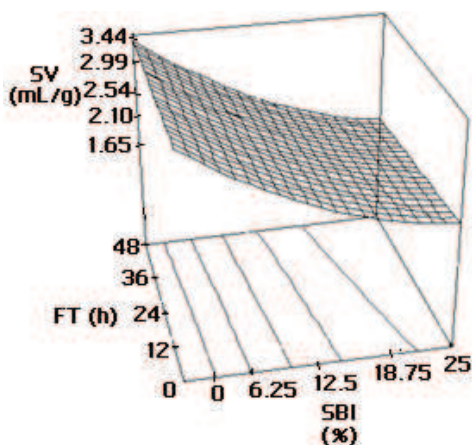

Fig. 3. Change on bread specific volume (SV) as a result of soybean isolate (SBI) addition and fermentation time (FT).

Bread crumb and crust quality

Sourdough bread quality was evaluated by the changes in the crumb and crust colour (luminosity, a^* and b^*), crumb textural parameters (compression force, firmness and resilience) and crumb grain structure (mean cell area, cell density and shape factor).

Crust and crumb colour.

Crumb and crust luminosity (L) were not affected ($P>0.05$) by the changes in soybean isolate concentration or fermentation time. Crust luminosity showed a mean value of 53, while crumb luminosity stood in a value of 60. Similar results were reported by Rosales-Juárez et al., (2008), however other studies have shown that bread becomes darker when adding soybean products at increasing levels (López-Guel et al., 2009; Marco & Rosell, 2008; Hellen et al., 2004). The differences could be the result of the kind of soybean product added and the proportion used as compared to other studies.

CIE Lab chromaticity parameters (a^* , b^*) were also evaluated at the crust and crumb of the sourdough bread. Figure 4 shows that the addition of soybean isolate increased ($P<0.0001$) the red colour of the crumb (a^*), while the crust colour was not affected by this variable ($P>0.05$). In both cases, fermentation time did not have significant effect ($P>0.05$). The red colour data (a^*) of the crumb was fitted to a lineal model ($P<0.0001$, Table 3) with a determination coefficient of 0.9113. These results do not accord with the ones reported by Rosales-Juárez et al., (2008) who described that soybean addition decreased the red colour of the crumb. The differences could be ascribed to the type and quantity of the soybean product added.

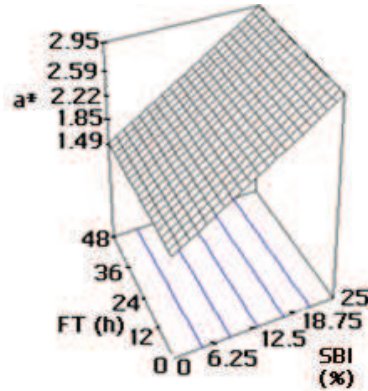

Fig. 4. Effect of soybean isolate (SBI) proportion and fermentation time (FT) on crumb red colour (a^*)

The changes in the CIE Lab chromaticity yellow-green parameter (b^*) followed a quadratic or lineal tendency ($P < 0.0001$, Table 3) when evaluating the crumb and crust of the sourdough breads respectively (Fig. 5A, 5B). In both cases, the yellow colour increased as the soybean isolate was risen in the formulation. Fermentation time presented a significant but smaller effect on crumb yellow colour. López-Guel et al., (2009) and Halle et al., (2004) reported similar results.

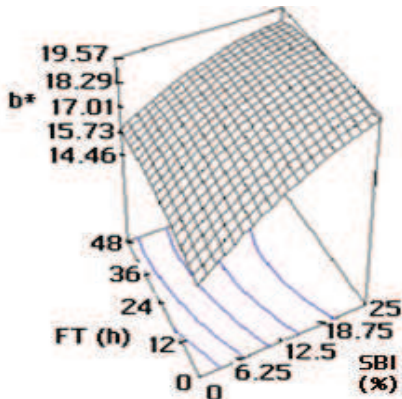

Fig. 5-A

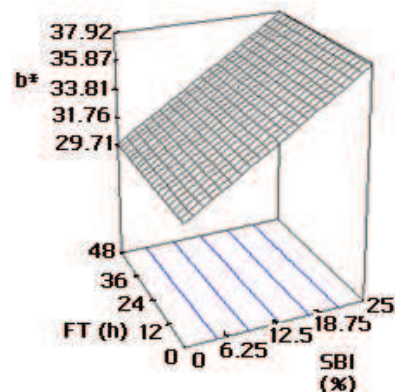

Fig. 5-B

Fig. 5. Effect of soybean isolate (SBI) and fermentation time (FT) on CIE Lab b^* parameter. A: crumb, B: crust.

Crumb texture

The changes in crumb texture were evaluated by measuring the compression force, firmness and resilience. These results are presented in Fig. 6 where it is possible to see that as the concentration of soybean isolate was increased in the formulation the compression force (Fig. 6A) also increased. Fermentation time showed a smaller but significant ($P < 0.05$) effect on this parameter. Data was fitted to a quadratic model (Table 3) with a determination

coefficient of 0.9097. Similar results were reported by Stauffer (2002) who showed that the bread added with soybean flour (3-12 g/ g flour) required a larger compression force. However other researchers found the opposite tendency (Leon et al., 2004). These discrepancies could be the result of the different materials and concentrations used in the experiments. Fig. 6B shows the changes in the crumb firmness, where the higher the concentration of soybean isolate the larger firmness of the product is. Fermentation time also had a significant effect on this response ($P < 0.0001$), being more notorious when adding more soybean isolate. Firmness data was fitted to a first degree polynomial model ($P < 0.0001$, Table 3) with a determination coefficient of 0.8474. Rosales-Juárez et al., (2008) reported a similar effect when adding soybean flour to white bread. On the other hand, resilience did not change with soybean isolate addition or fermentation time ($P > 0.05$), remaining almost constant (0.16) for all the conditions tested. Marco & Rosell (2008) reported similar results. Table 3 shows the response surface mathematical models of the evaluated parameters.

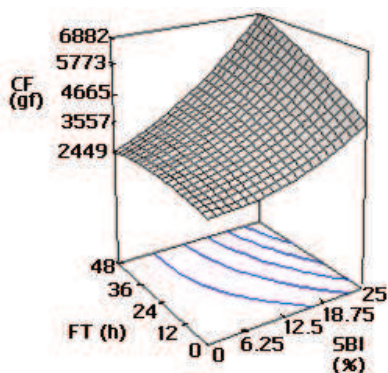

Fig. 6-A

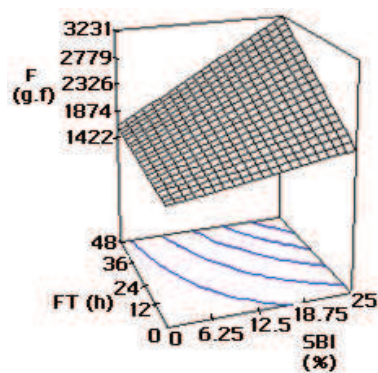

Fig. 6-B

Fig. 6. Changes in the compression force (CF) (A) and firmness (F) (B) of sourdough crumb bread as affected by soybean isolate (SBI) addition levels and fermentation time (FT).

Crumb grain structure

Crumb grain structure was evaluated by image analysis, reporting mean cell area (mm^2), cell density (pores/ cm^2) and shape factor (Figure 7). Results showed that the addition of soybean isolate or the fermentation time did not affect the size of the crumb bread pores (0.23-0.29 mm^2). Cell density and shape factor were not either affect by soy isolate addition or fermentation time, showing average values of 42 pores/ cm^2 and 0.75 respectively. Rosales-Juárez et al., (2008) reported similar results. On the other hand, Lagrain et al., (2006) and Zghal et al., (1999) reported mean cell areas ranging from 77 to 112 pores/ cm^2 for white bread, which means that the soybean isolate addition promotes a more open structure. Statistical analysis showed that any of the variables has a significant effect ($P > 0.05$) on any of the responses.

| Response surface model | Equation |
|---|----------|
| $MCT^{-1} = 0.1089 + 2.1515 \times 10^{-3} SBI - 3.0247 \times 10^{-4} FT$ | 1 |
| $\ln S = 1.99 - 0.084 SBI - 2.7 \times 10^{-3} FT + 2.3 \times 10^{-3} SBI^2 + 1.5 \times 10^{-4} FT^2 - 1.9 \times 10^{-4} SBI FT$ | 2 |
| $TA = 0.57 + 0.03 SBI + 9.3 \times 10^{-3} FT - 7.4 \times 10^{-4} SBI^2 - 1.2 \times 10^{-4} FT^2 - 6.7 \times 10^{-5} SBI FT$ | 3 |
| $pH = 5.1 + 0.05 SBI - 2.3 \times 10^{-3} FT - 7.1 \times 10^{-4} SBI^2 - 2.1 \times 10^{-4} FT^2 + 1.9 SBI FT$ | 4 |
| $SV = 3.4 - 0.11 SBI - 8.3 \times 10^{-4} FT + 1.9 \times 10^{-3} SBI^2 - 2.1 \times 10^{-5} FT^2 - 1.1 SBI FT$ | 5 |
| $A = 1.5 + 0.06 SBI + 3.5 \times 10^{-4} FT$ | 6 |
| $B = 14.5 + 0.3 SBI + 0.07 FT - 3.9 \times 10^{-3} SBI^2 - 7.8 \times 10^{-4} FT^2 - 1.5 \times 10^{-3} SBI FT$ | 7 |
| $BC = 29.7 + 0.3 SBI + 3.3 \times 10^{-3} FT$ | 8 |
| $CF = 2457 - 10.6 SBI + 20.6 FT + 3.4 SBI^2 - 0.4 FT^2 + 2.1 SBI FT$ | 9 |
| $F = 1421 + 18.5 SBI + 4.3 FT + 0.95 SBI FT$ | 10 |

Table 3. Response surface models of the evaluated parameters. MCT: maximum consistency time (min); S: stability (min); TA: titratable acidity (%); SV: specific volume (cm³/g); A: crumb chromaticity "a" value; B: crumb chromaticity "b" value; BC: crust chromaticity "b" value; CF: compression force (g); F: firmness (g). SBI: Soybean isolate concentration (g/100 g flour); FT: fermentation time (min).

Sensory analysis

As the effect of fermentation time was negligible for many of the parameters evaluated, the breads fermented for 48 h and at both levels of soybean isolate addition were selected. Results show that both samples were accepted without having significant differences between them ($P < 0.05$). Figure 8 shows this information.

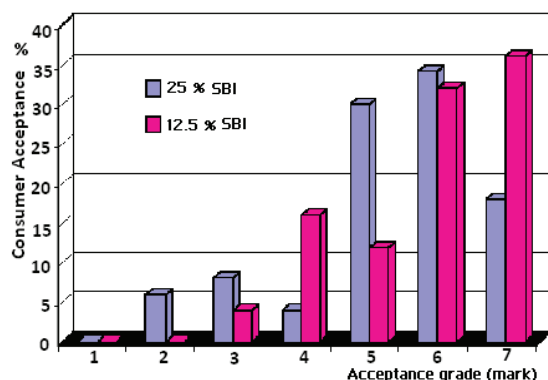

Fig. 8. Sensory analysis evaluation of soybean isolate added bread.

It can also be seen from this information that as the amount of soybean isolate added to the formulation increased the level of acceptance by the panellists decreased, which could be related to the off flavours generated by these high levels of soybean (Rosales-Juárez et al., 2008; Olaoye et al., 2006; McWatters et al., 2003). Even though it is possible to consider that the process of fermentation helps to hide the off flavours of soybean as the level of substitution was higher as compared to other published reports and both samples were well accepted.

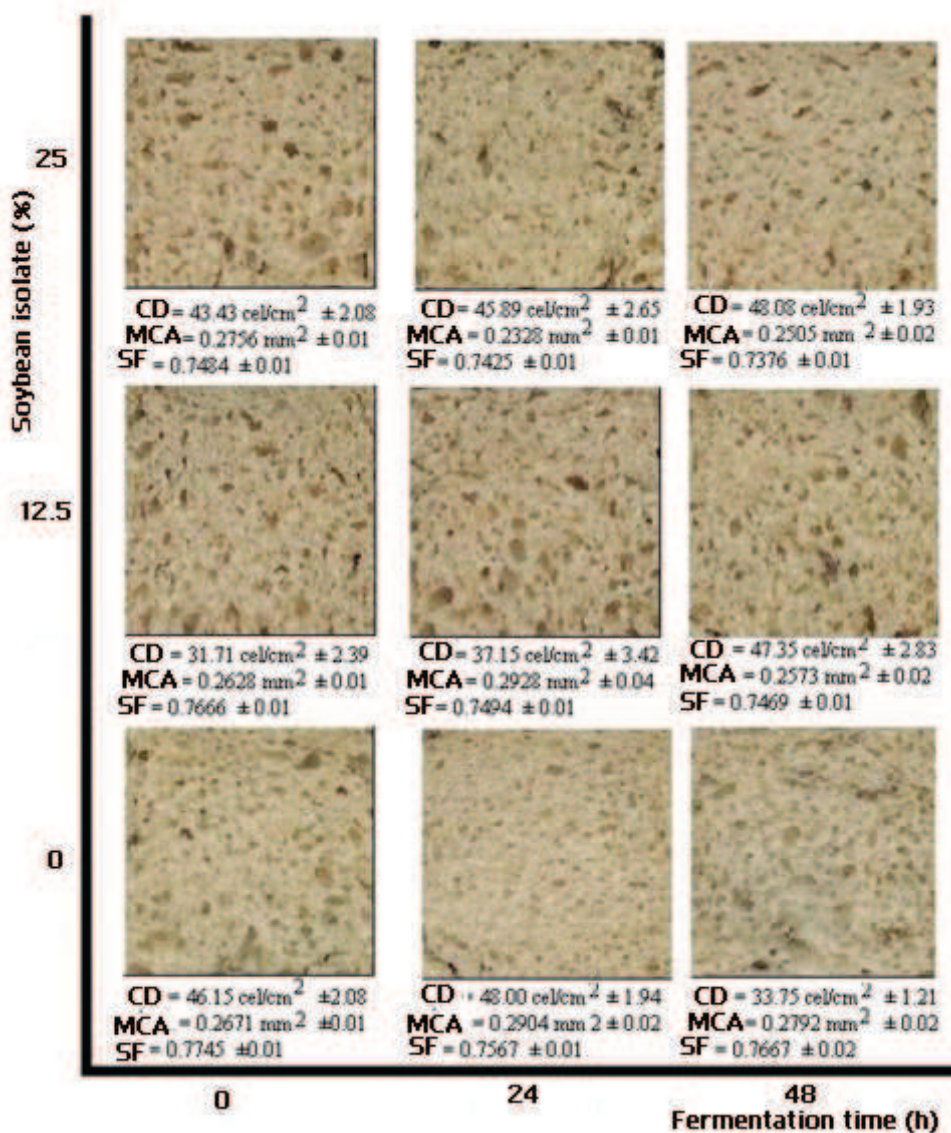

Fig. 7. Crumb grain structural analysis of sourdough breads added with different levels of soybean isolate (SBI) and fermented for different times (FT). CD: cell density, MCA: mean cell area; SF: shape factor. Results are the mean value of three repetitions \pm standard deviation.

Biological protein quality analysis

Table 4 shows the protein biological indexes calculated: protein efficiency ratio (PER), net protein ratio (NPR), apparent digestibility (AD) and true digestibility (TD).

| | Control | 12.5 % SI-sourdough bread | 25% SI-sourdough bread |
|--------|------------|---------------------------|------------------------|
| PER | 1.8 ± 0.3 | 2.2 ± 0.4 | 2.4 ± 0.3 |
| NPR | 2.4 ± 0.3 | 2.7 ± 0.4 | 2.9 ± 0.3 |
| D (%) | 80.7 ± 1.9 | 83.1 ± 3.2 | 84.4 ± 1.8 |
| TD (%) | 85.6 ± 2.1 | 87.7 ± 2.9 | 88.2 ± 1.8 |

Table 4. Protein quality biological indexes of three diets made of soybean isolate sourdough bread. SI: soybean isolate. PER: protein efficiency ratio; NPR: net protein ratio; D: apparent digestibility; TD: true digestibility.

It can be observed from these results that the addition of soybean isolate (as expected) significantly increased ($P < 0.05$) the PER and the NPR indexes of the sourdough bread as compared to the control sample. However there were no differences between the two samples added with soybean isolate and in the digestibility values (D, TD) either. This information shows that depending on the purpose of the product (better protein quality or nutraceutical bread), the addition of soybean isolate can be carried out at both substitution levels.

Changes on protein fractions during the bread making process of sourdough

Figure 9 shows the change in the electrophoretical pattern of NaCl soluble proteins. These results showed that the globulin fraction was mainly affected by the baking stage, while the fermentation process had an effect on the higher molecular weight subunits, as well as in the lowest molecular weight subunits. The other fractions (prolamins and glutelins) were mainly affected during baking, without an appreciable change in conformation.

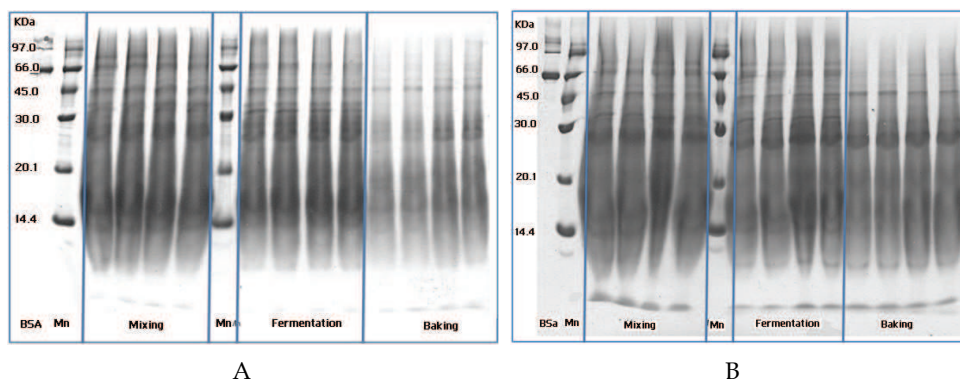

Fig. 9. Changes in the electrophoretical pattern of NaCl soluble proteins of sourdough added with different soybean isolate (SBI) concentrations. A:12.5% SBI; B: 25% SBI.

4. Conclusions

Adding soybean isolate to produce sourdough bread resulted in a product with lower volume than then control but with good acceptance by consumers. The off flavour of

soybean was hidden by the sour flavour of the bread, besides that the nutritional quality was highly improved. Rheological properties were affected by the addition, as well as the texture of the product.

5. References

- American Association of Cereal Chemists. (2000). Method 10-05. Approved Methods of the AACC. USA.
- Badger, T.; Ronis, M.; Simmen, R. & Simmen, F. (2005). Soy protein isolate and protection against cancer, In: *J Am Coll Nutr*, 24, 2, 146S-149S
- Badui, D. (1993). Química de los alimentos, tercera edición; Editorial Pearson Educación, México
- Barnes, S. (1995). Effect of genistein on in vitro and in vivo models of cancer, In: *J Nutr*, 125, 777S-781S
- Basman, H. & Köksel, PKW. (2003). Utilizations of transglutaminase to increase the Level of barley and soy flour incorporation in wheat flour breads, In: *J. Food Sci.*, 68, 8 2453-2460
- Calaveras, J. (1996). Tratado de panificación y bollería, AMV ediciones, 226-243.
- Calderón-Domínguez, G., Neyra-Guevara, M., Farrera-Rebollo, R., Arana-Erassquín, R., & Mora-Escobedo, R. (2003). Structural and farinographic changes during mixing of a yeast sweet dough. In: *Nahrung*, 47(5), 312-319.
- Calderón, DG.; Vera, DM.; Farrera, RR.; Arana, ER. & Mora, ER. (2004). Rheological changes of dough and bread prepared from a sweet dough: effect of temperature and mixing time, In: *J. Food Properties*, 7, 165-174
- Charmaine, IC.; Tilmán, J S.; Peter, D.; Dockery, OS. & Elke, K.A.(2004). Wheat Sourdough Fermentation: effects of time and acidification on fundamental rheological properties., In: *American Association of Cereal Chemists*, 81,3, 409-417
- Dubois DK. (1980). Usos de la soya en productos de panificación, In: *American Institute of banking*, Manhattan, Kansas USA
- Dhingra, S. & Jood, S. (2004). Effect of flour blending on functional, baking and organoleptic characteristics of bread, In: *Int J Food Sci Tech*, 39, 213-22.
- FAO -OMS, (2003). Informe sobre salud en el mundo, <http://www.fao-oms.org>.
- Gálvez, AF.; Chen, N.; Macasieb, J. & de Lumen, BO. (2001). Chemopreventive property of a soybean peptide (lunasin) that binds to deacetylated histones and inhibits acetylation. In: *Cancer Res*, 61, 20, 7473-7478
- Hawrylewicz, EJ.; Zapata, J. & Blair, W. (1995). Soy and experimental cancer: animal studies, In: *J Nutr*, 125, 698S-708S
- Hallen, E.; Ibanaglu, S. & Ainsworth, P. (2004). Effect of fermented / germinated cowpea flour addition on rheological and baking properties of wheat flour, In: *J. Food Engineering*, 63, 177-184
- Hegazy, AN. & Siham, MN. (1990). Rheological and sensory characteristics of doughs and cookies based an wheat , soybean, chick pea and lupine flour, in: *Die Nahrung*, 34, 9, 835-841
- Indrani, D.; Prabhasankar, P.; Rajiv, J. & Venkateswara, G R. (2007). Influence of whey protein concentrate on the rheological characteristics of dough, microstructure and quality of unleavened flat bread, In: *Food Research International*, 40,1254-1260.

- Indrani, D.; Savithri, GD. & Venkateswara, GR. (1997). Effect of defatted soy flour on the quality of buns, In: *Journal of Food Science and Technology*, 34, 5, 440-442.
- Kennedy, AR. (1995). The evidence for soybean products as cancer preventive agents, In: *J Nutr*, 125, 733S-743S
- Lagrain, B.; Boeckx, L.; Wilderjans, E.; Delcour, J. A. & Lauriks, W. (2006). Non-contact ultrasound characterization of bread crumb: application of the Biot-Allard model, In: *Food research International*, 39, 1067-1075.
- León, MA.; Montoya, IO.; Motato, EK.; Granda, MD.; Caro, AC.; Restrepo, MJ.; Echeverri, S.; Valencia, J. & Quinchia, L. (2006). Bacterias acidolácticas (BAL) silvestres Colombianas presentan propiedades adecuadas para la fabricación de masa ácida. In: *ISSN 0121 T 4004*, 13, 2, 26 - 35.
- León, EA. & Rosell, MC. (2007). De tales harinas, tales panes. Granos, harinas y productos de panificación en Iberoamérica. Baez impresiones, primera edición, Argentina. Pp. 17-194
- López-Guel, E. C., Lozano-Bautista, F., Mora-Escobedo, R., Farrera-Rebollo, R. R., Chanona-Pérez, J., Gutiérrez-López, G. F., Calderón-Domínguez, G. 2009. Effect of soybean 7S protein fractions, obtained from germinated and nongerminated seeds, on dough rheological properties and bread quality. *Food Bioprocess Technology* DOI 10.1007/s11947-009-0277-9.
- Maforimbo, E.; Nguyen, M. & Skurray, GR. (2006). The effect L-Ascorbic acid on the rheological properties of soy-wheat dough: a comparison of raw and physically modified soy flours, In: *J. Food Eng.*, 72, 4, 339-345
- Marco, C. & Rosell, CM. (2008). Breadmaking performance of protein enriched, gluten-free breads, In: *Eur Food Res Technol*. Original paper.
- Martin, DS.; (2001). Dietary soy exerts and antihypertensive effect in spontaneously hypertensive female rats, In: *American Journal of Physiology and Regulatory Integrative Comparative Physiology*, R553 - R560
- Mascarós, A.F.; Collar, C.; 1994. Metabolismo de levaduras y bacterias ácido lácticas durante la fermentación en relación con las características funcionales de la masa fermentada. *Rev Esp Ciencia Tgía Altos*; 34(6):623-642.
- McWatters, KH.; Ouedraogo, JB.; Resurreccion, AV.; Hung, Yen-C. & Phillips, R. D. (2003). Physical and sensory characteristics of sugar cookies containing mixtures of wheat, fonio (*Digitaria exilis*) and cowpea (*Vigna unguiculata*) flours, In: *International Journal of Food Science and technology*, 38, 403 -410
- Olaoye, OA.; Onilude, AA. & Idowu, OA. (2006). Quality characteristics of bread produced from composite flours of wheat, plantain and soybeans, In: *African Journal of Biotechnology*, 5, 11, 1102 - 1106
- Rao, AV. & Sung, MK. (1995). Saponins as anticarcinogens, In: *J Nutr*, 25, 717S-724S
- Ribotta, DP.; Arnulphi, AS.; León, EA. & Añón, CM. (2005). Effect of soybean addition on the rheological properties and breadmaking quality of wheat flour, In: *Journal of the Science of food and Agriculture*, 85, 11, 1889 - 1896.
- Rosales-Juárez, M.; González-Mendoza, B.; López-Guel, EC.; Lozano-Bautista, F.; Chanona-Pérez, J.; Gutiérrez-López, G.; Farrera-Rebollo, R. & Calderón-Domínguez, G. (2008). Changes on dough rheological characteristics and bread quality as a result of the addition of germinated and non-germinated soybean flour, In: *Food Bioprocess Technol.* 1, 152-160.

- Sabanis, D. & Tzia, C. (2009). Effect of rice, corn and soy flour addition on characteristics of bread produced from different wheat cultivars, In: *Food Bioprocess Technol*, 9, 2, 68 - 79.
- Sapirstein, HD.; Roller, R. & Bushuk, W. (1994). Instrumental measurement of bread crum grain by digital image analysis, In: *Cereal Chem*, 71, 4, 383 - 391
- Stauffer, CE. (2002). La proteína de soya en el horneado, In: *Technical Foods Consultants*, 18, Cincinnati, Ohio, USA
- Shogren, RL., Mohamed, AA. & Carriere, CJ. (2003). Sensory analysis of whole wheat/soy flour breads, In: *J Food Sci*, 68, 2141- 5.
- Vucenik, I. & Shamsuddin, A. (2003). Cancer inhibition by inositol hexaphosphate (IP6) and inositol: from laboratory to clinic, In: *J Nutr*, 133, 3778S-3784S
- Zghal, MC.; Scanlon, MG. & Sapirstein, HD. (1999). Prediction of bread crumb density by digital image lysis, In: *Cereal Chem.*, 76, 5, 734 - 742

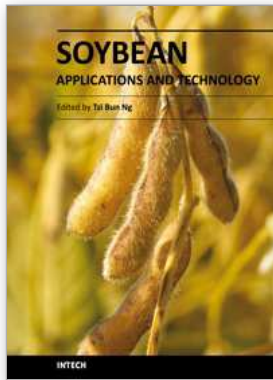

Soybean - Applications and Technology

Edited by Prof. Tzi-Bun Ng

ISBN 978-953-307-207-4

Hard cover, 402 pages

Publisher InTech

Published online 26, April, 2011

Published in print edition April, 2011

Soybean is an agricultural crop of tremendous economic importance. Soybean and food items derived from it form dietary components of numerous people, especially those living in the Orient. The health benefits of soybean have attracted the attention of nutritionists as well as common people.

How to reference

In order to correctly reference this scholarly work, feel free to copy and paste the following:

Josué Peñaloza- Espinosa, Gloria J. De La Rosa-Angulo, Rosalva Mora-Escobedo, Jorge Chanona-Pérez, Reynold Farrera-Rebollo and Georgina Calderón-Domínguez (2011). Sourdough and Bread Properties as Affected by Soybean Protein Addition, *Soybean - Applications and Technology*, Prof. Tzi-Bun Ng (Ed.), ISBN: 978-953-307-207-4, InTech, Available from: <http://www.intechopen.com/books/soybean-applications-and-technology/sourdough-and-bread-properties-as-affected-by-soybean-protein-addition>

INTECH

open science | open minds

InTech Europe

University Campus STeP Ri
Slavka Krautzeka 83/A
51000 Rijeka, Croatia
Phone: +385 (51) 770 447
Fax: +385 (51) 686 166
www.intechopen.com

InTech China

Unit 405, Office Block, Hotel Equatorial Shanghai
No.65, Yan An Road (West), Shanghai, 200040, China
中国上海市延安西路65号上海国际贵都大饭店办公楼405单元
Phone: +86-21-62489820
Fax: +86-21-62489821

© 2011 The Author(s). Licensee IntechOpen. This chapter is distributed under the terms of the [Creative Commons Attribution-NonCommercial-ShareAlike-3.0 License](#), which permits use, distribution and reproduction for non-commercial purposes, provided the original is properly cited and derivative works building on this content are distributed under the same license.